



OPERATOR'S MANUAL

INTERNATIONAL[®]

CUB CADET[®]

73, 106, 107, 126,
127, and 147

Tractors and
Rotary Mowers

OPERATION
MAINTENANCE
LUBRICATION

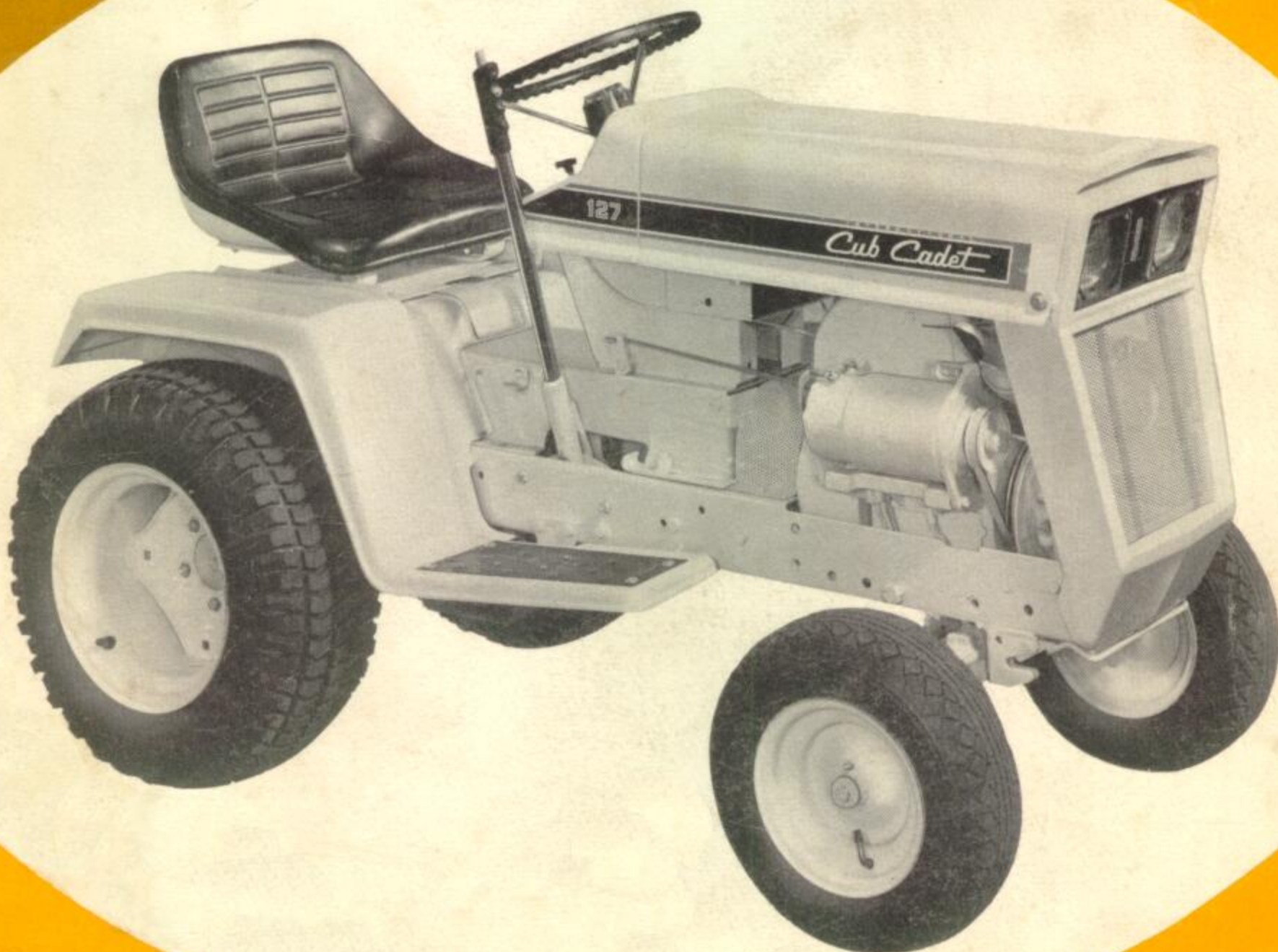

To The Owner

Assembled in this manual are operation, lubrication, and maintenance instructions for the International Cub Cadet 73, 106, 107, 126, 127, and 147 Tractors. The material has been prepared in detail to help you better understand the correct care and efficient operation of your tractor. Before you operate the tractor, study this manual carefully. New copies may be ordered from your dealer at a nominal price.

Your local International Harvester dealer is interested in the performance you receive from this tractor. He has factory-trained servicemen, informed in the latest method of servicing tractors, modern tools, and original-equipment IH service parts which assure proper fit and good performance.

The International Cub Cadet 107, 127, and 147 Tractors have a hydrostatic drive. It is the best hydraulic drive unit available and will require minimum service if recommended operating and maintenance procedures are

followed. Should you have difficulties with the unit consult your International Harvester dealer. **UNDER NO CIRCUMSTANCES SHOULD YOU ATTEMPT TO SERVICE THESE UNITS YOURSELF.** Only your dealer is authorized to repair or replace units on this drive under the terms of the warranty. Should you desire additional information not found in this manual, contact your International Harvester dealer.

The International Cub Cadet 73, 106 and 126 Tractors have a conventional clutch and transmission.

To obtain top performance and assure economical operation the tractor should be inspected, depending on its use, periodically, or at least once a year, by your International Harvester dealer.

When in need of parts, always specify the model, chassis and engine serial numbers, including the prefix and suffix letters. Write these serial numbers in the space provided below.

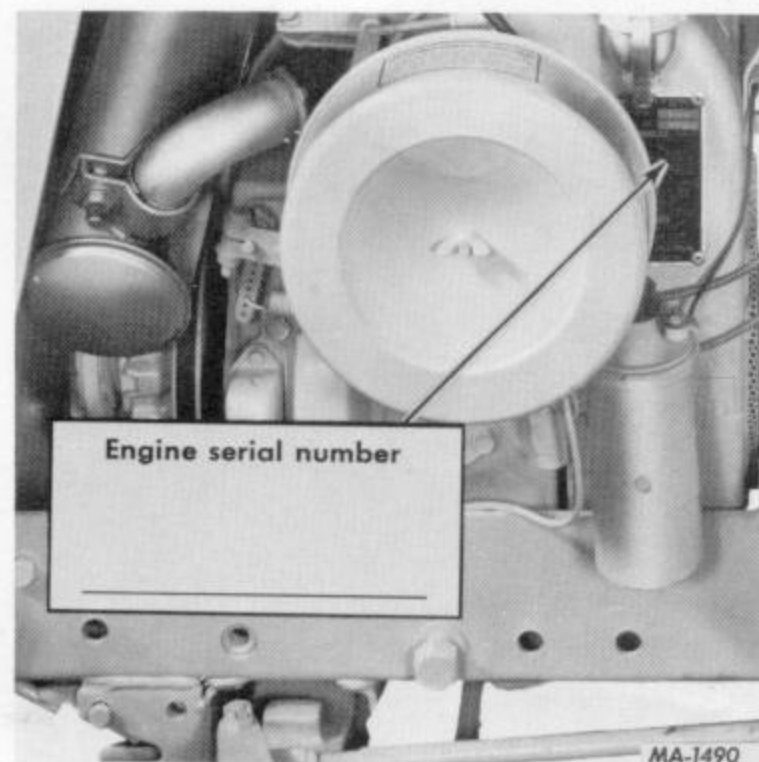
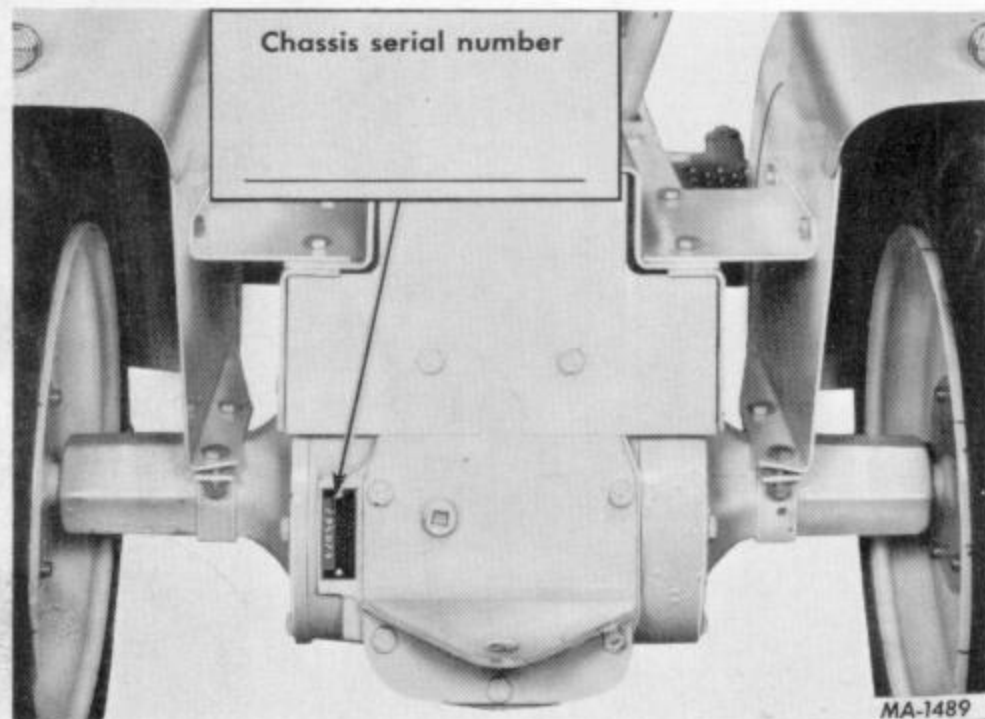

MODEL _____
DELIVERY DATE _____

INTRODUCTION

A variety of extra equipment and accessories is available. Where operating and maintaining instruction is required, it is included in the instruction for operating and maintaining the tractor. Disregard the instructions for equipment not on your tractor.

The illustrations in this manual are numbered to correspond with the pages on which

they appear; for example, **Illust. 7 on page 7.**

LEFT and RIGHT indicate the left and right sides of the tractor when facing forward in the driver's seat. Reference to FRONT indicates the grille end of the tractor; to REAR the drawbar end.

SERVICE MANUAL INFORMATION

Description	Page No.
INTRODUCTION	Includes cover 1, 2
ORDER FORM FOR SERVICE MANUAL	
CONTENTS	
SAFETY	
INSTRUMENTS AND CONTROLS	
BEFORE OPERATING	
FUEL SYSTEM	
DRIVING THE TRACTOR	
HITCHING EQUIPMENT TO	
REAR POWER TAKE-OFF	
FRONT POWER TAKE-OFF	
ELECTRIC LIFT	
ENGINE COOLING AND AIR	
ELECTRICAL SYSTEM	
PNEUMATIC TIRES	
FRONT WHEELS	
CLUTCH BRAKE	
OPERATING THE TRACTOR	
EXTENDING THE TRACTOR	
TROUBLE SHOOTING	
LUBRICATION	
LUBRICATION GUIDE	
SPECIAL INSTRUCTIONS (INTERNATIONAL ROTARY MOWERS)	
BEFORE OPERATING YOUR MOWER	
ADJUSTING AND OPERATING	
STARTING AND STOPPING THE MOWER	
LEVEL ADJUSTMENT	
HEIGHT ADJUSTMENT	
CLEANING	
DISASSEMBLING	
ASSEMBLING AND DETACHING THE MOWER	
SAFETY INSTRUCTIONS	

Your International Harvester Dealer and his factory trained servicemen are best qualified to service your equipment. Up to date instructions and adequate special tools are also a part of your Dealer's service facilities.

This Operator's Manual was prepared to instruct you in proper operation and maintenance of your equipment. If you desire additional information you may purchase a Service Manual.

Tear off this order blank and forward, with your check for \$3.00 to:

International Harvester Company
INTERNATIONAL HARVESTER PRESS
4829 South Kedzie Avenue
Chicago, Illinois 60632

Attention: Cashier

Cut along this line

Please send me one - GSS 1404 Service Manual for Cub Cadets and International Harvester Equipment. My check for \$3.00 is enclosed.

Please Print

NAME _____

ADDRESS _____

Signed

SERVICE MANUAL INFORMATION

...of instructions for maintenance and...
...and International...
...of your equipment. If you desire additional information you may...
...purchase a Service Manual...
...with your check for \$5.00...
...to obtain a copy of this manual...
...INTERNATIONAL HARVESTER TRACTOR...
...8853 South Keno Avenue...
...Chicago, Illinois 60632

...with...
...of your equipment...
...purchase a Service Manual...
...with your check for \$5.00...
...to obtain a copy of this manual...
...INTERNATIONAL HARVESTER TRACTOR...
...8853 South Keno Avenue...
...Chicago, Illinois 60632

...of your equipment...
...purchase a Service Manual...
...with your check for \$5.00...
...to obtain a copy of this manual...
...INTERNATIONAL HARVESTER TRACTOR...
...8853 South Keno Avenue...
...Chicago, Illinois 60632

...of your equipment...
...purchase a Service Manual...
...with your check for \$5.00...
...to obtain a copy of this manual...
...INTERNATIONAL HARVESTER TRACTOR...
...8853 South Keno Avenue...
...Chicago, Illinois 60632

...of your equipment...
...purchase a Service Manual...
...with your check for \$5.00...
...to obtain a copy of this manual...
...INTERNATIONAL HARVESTER TRACTOR...
...8853 South Keno Avenue...
...Chicago, Illinois 60632

...of your equipment...
...purchase a Service Manual...
...with your check for \$5.00...
...to obtain a copy of this manual...
...INTERNATIONAL HARVESTER TRACTOR...
...8853 South Keno Avenue...
...Chicago, Illinois 60632

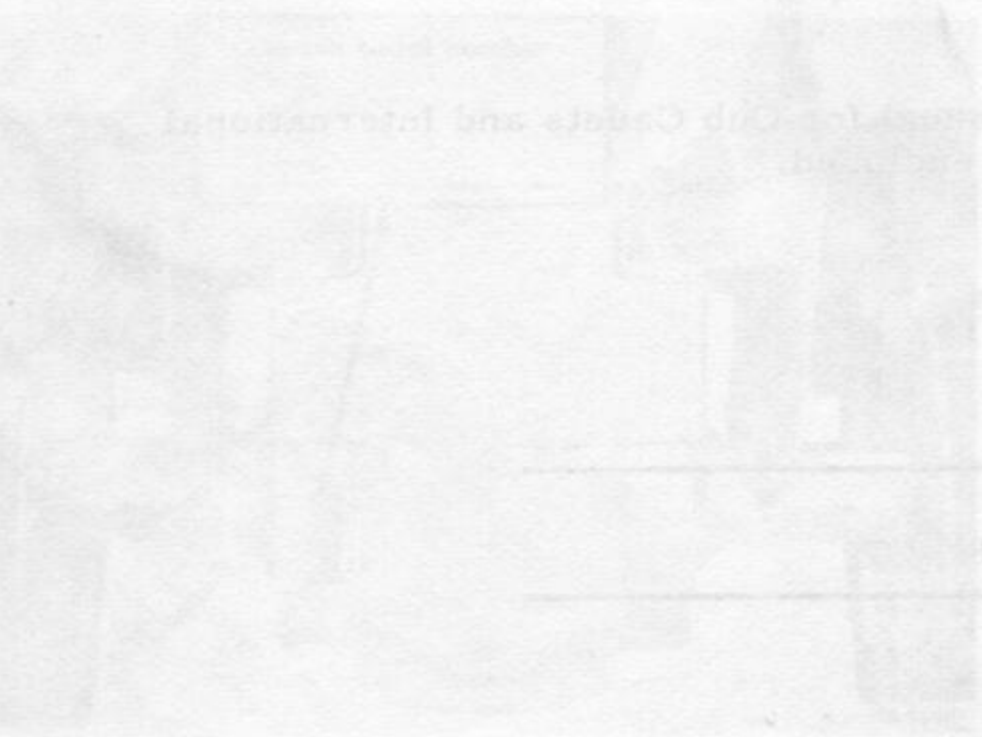

DELIVERY DATE _____

DELIVERY DATE _____

INTRODUCTION

...of your equipment...
...purchase a Service Manual...
...with your check for \$5.00...
...to obtain a copy of this manual...
...INTERNATIONAL HARVESTER TRACTOR...
...8853 South Keno Avenue...
...Chicago, Illinois 60632

...of your equipment...
...purchase a Service Manual...
...with your check for \$5.00...
...to obtain a copy of this manual...
...INTERNATIONAL HARVESTER TRACTOR...
...8853 South Keno Avenue...
...Chicago, Illinois 60632

CONTENTS

Description	Page No.
INTRODUCTION	Inside cover 1, 2
ORDER FORM FOR SERVICE MANUAL	1
CONTENTS	3
SAFETY INSTRUCTIONS	4
INSTRUMENTS AND CONTROLS	5, 6, 7
BEFORE OPERATING YOUR NEW TRACTOR	8
OPERATING THE ENGINE	8, 9
FUEL SYSTEM	9, 10
DRIVING THE TRACTOR	11, 12, 13
HITCHING EQUIPMENT TO THE TRACTOR	13, 14
REAR POWER TAKE-OFF	15
FRONT POWER TAKE-OFF	16
ELECTRIC LIFT	17
ENGINE COOLING AND AIR CLEANER	17, 18
ELECTRICAL SYSTEM	18, 19, 20
PNEUMATIC TIRES	20, 21
FRONT WHEELS	21
CLUTCH-BRAKE	22 to 25
STORING THE TRACTOR	25
EXTRA EQUIPMENT AND ACCESSORIES	26
TROUBLE SHOOTING	26, 27
LUBRICATION	27, 28
LUBRICATION TABLE	28
LUBRICATION GUIDE	29 to 35
SPECIFICATIONS	35 to 38
OPERATING INSTRUCTIONS (INTERNATIONAL ROTARY MOWERS)	39 to 44
INTRODUCTION	40
BEFORE OPERATING YOUR MOWER	40
ADJUSTING AND OPERATING	41
Lubrication	41
Starting and stopping the mower	42
Level adjustment	42
Height of cut	42
V-Belt	42
Cleaning	42
Blade care	43
Mowing	43
General	43
Attaching and detaching the mower	43
Safety suggestions	43
INDEX	45, 46

SAFETY INSTRUCTIONS

- | Page No. | Description |
|----------|-----------------------------------|
| 5 | INTRODUCTION |
| 1 | ORDER FORM FOR SERVICE MANUAL |
| 3 | CONTENTS |
| 5 | INSTRUMENTS AND CONTROLS |
| 8 | BEFORE OPERATING YOUR NEW TRACTOR |
| 11 | FUEL SYSTEM |
| 13 | DRIVING THE TRACTOR |
| 16 | HITTING EQUIPMENT TO THE TRACTOR |
| 17 | REAR VIEW MIRROR |
| 20 | ELECTRICAL SYSTEM |
| 21 | PNEUMATIC TIRES |
| 25 | CLUTCH BRAKE |
| 28 | DRIVING THE TRACTOR |
| 32 | EXTRA EQUIPMENT AND ACCESSORIES |
| 35 | LUBRICATION TABLE |
| 39 | ROTOR MOWER |
| 41 | Y-Belt |
| 42 | Cleaning |
| 43 | Blade Care |
| 43 | Mowing |
| 43 | General |
| 43 | Attaching and detaching the mower |
| 43 | Safety suggestions |
| 45 | INDEX |
1. Disengage all clutches and shift into neutral before starting the engine.
 2. Disengage power to any attachments and stop engine before leaving operator's seat or making any repairs or adjustments.
 3. Know the controls and how to stop quickly - READ THE OPERATOR'S MANUAL.
 4. Do not allow children or adults to operate the equipment without proper instruction.
 5. Clear work area of objects which might be picked up and thrown.
 6. Disengage power to any attachment when transporting or not in use.
 7. Do not carry passengers. Keep children and pets a safe distance away.
 8. Take precautions, such as disengaging power take-off, shifting into neutral, setting the parking brake, stopping the engine and removing ignition key when leaving machine unattended.
 9. Reduce speed on slopes and in sharp turns to prevent tipping or loss of control.
 10. Stay alert for holes in terrain and other hidden hazards.
 11. Don't stop or start suddenly when going uphill or downhill.
 12. Use care when pulling loads or using heavy equipment: - A. Use only approved drawbar hitch points. B. Limit loads to those you can safely control. C. Don't turn too sharp, and use care when backing. D. Use counterweight or wheel weights when suggested in Operator's Manual.
 13. Watch out for traffic when crossing or near roadways.
 14. When using any attachments, never direct discharge of material toward bystanders nor allow anyone near the machine while in operation.
 15. Handle gasoline with care - it is highly flammable: - A. Use approved gasoline container. B. Never remove the fuel tank cap or fill the fuel tank when the engine is running, is hot, or fill the fuel tank indoors. Also, do not smoke when working around inflammable fuel. Wipe up spilled gasoline. C. Replace gasoline cap securely. D. Open doors if engine is running in a garage - exhaust gasses are dangerous.
 16. Keep machine in good operating condition and keep safety devices in place. Use guards as instructed in Operator's manual.

INSTRUMENTS AND CONTROLS

Your Cub Cadet Tractor has been safety engineered. Thoroughly acquaint yourself with all the instruments and controls before attempting to start or operate the tractor.

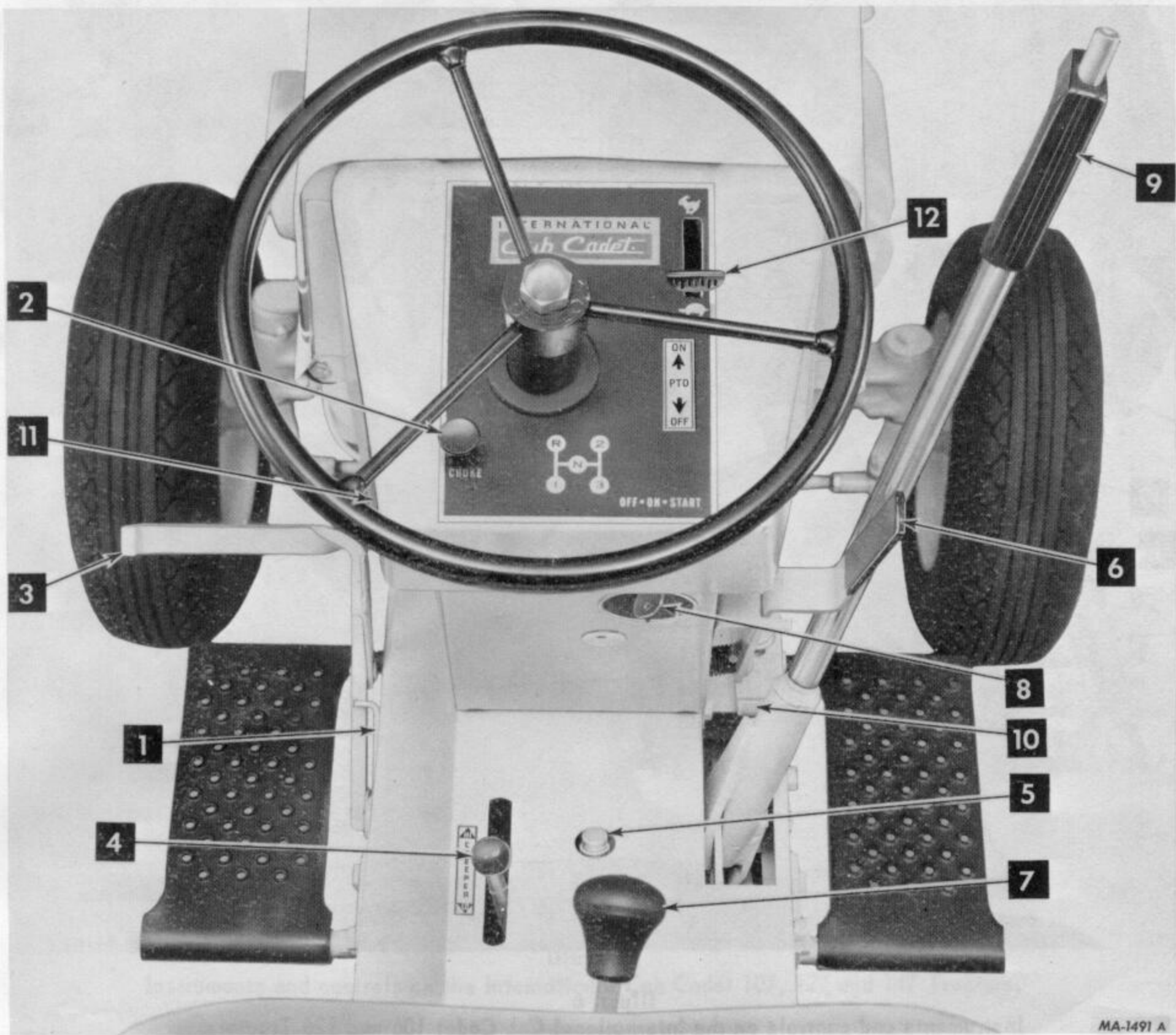

MA-1491 A

Illustr. 5
Instruments and controls on the International Cub Cadet 73 Tractor.

1. Brake pedal lock	See pages 12, 13
2. Choke control button	See page 9
3. Clutch-brake pedal	See pages 11, 12
4. Creeper shift lever *	See page 12
5. Creeper drive housing breather	
6. Front power take-off clutch lever	See page 16
7. Gearshift lever	See page 12
8. Ignition switch	See page 18
9. Lift handle	See pages 13, 14
10. Lift handle stop	See page 14
11. Lighting switch button *	See page 19
12. Throttle lever	See page 8

* Optional Equipment

INSTRUMENTS AND CONTROLS

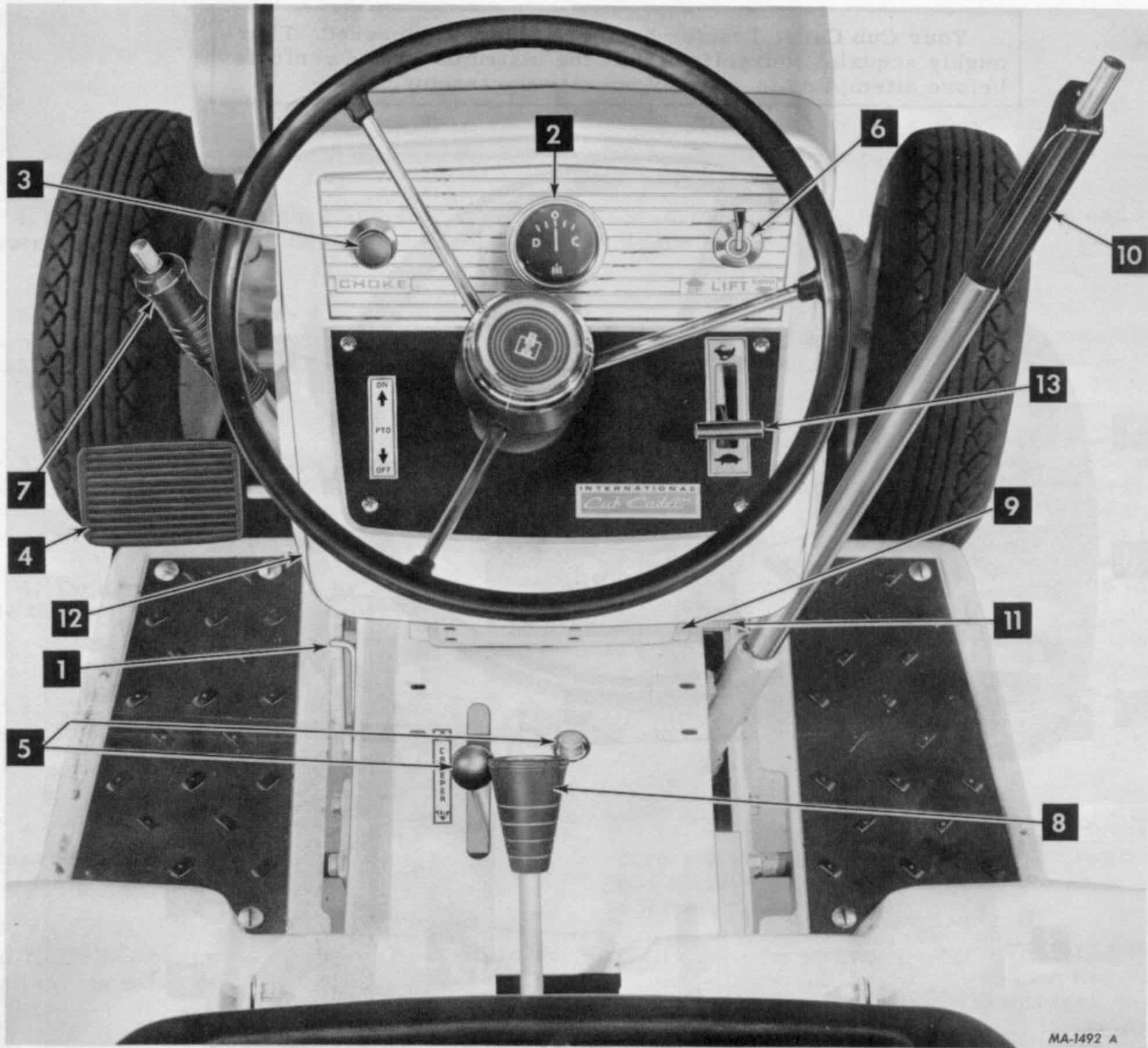

Illust. 6
Instruments and controls on the International Cub Cadet 106 and 126 Tractors.

1. Brake pedal lock	See pages 12, 13
2. Charge indicator	See page 18
3. Choke control button	See page 9
4. Clutch-brake pedal	See pages 11, 12
5. Creeper drive shift lever and housing breather *	See page 12
6. Electric lift control switch *	See page 17
7. Front power take-off clutch lever	See page 16
8. Gearshift lever	See page 12
9. Ignition switch	See page 18
10. Lift handle	See pages 13, 14
11. Lift handle stop	See page 14
12. Lighting switch button *	See page 19
13. Throttle lever	See page 8
Cigarette lighter *(Not shown)	See page 18

* Optional Equipment

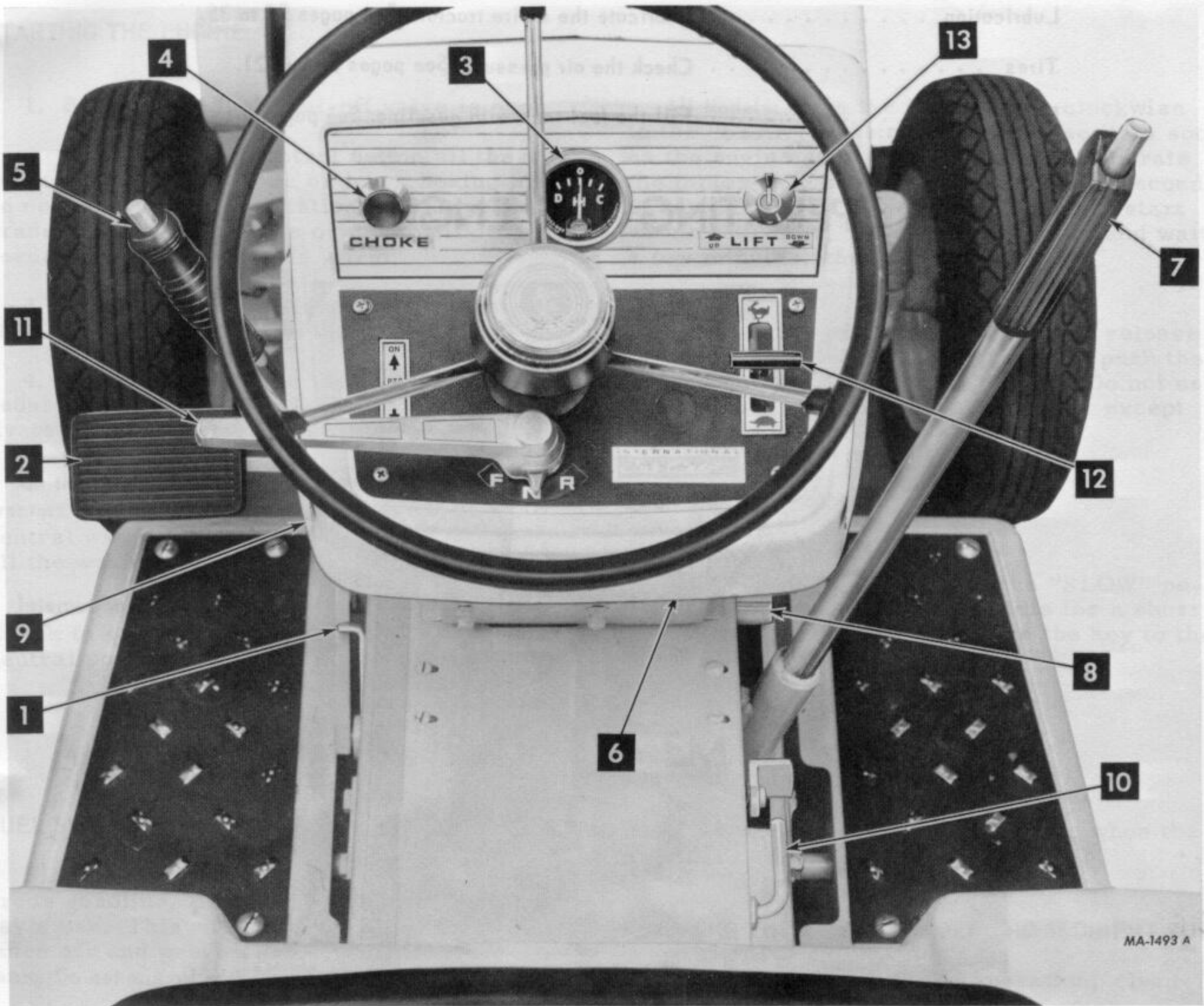

MA-1493 A

Illust. 7
Instruments and controls on the International Cub Cadet 107, 127, and 147 Tractors.

1. Brake pedal lock	See pages 12, 13
2. Clutch-brake pedal	See pages 11, 12
3. Charge indicator	See page 18
4. Choke control button	See page 9
5. Front power take-off clutch lever	See page 16
6. Ignition switch	See page 18
7. Lift handle	See pages 13, 14
8. Lift handle stop	See page 14
9. Lighting switch button	See page 19
10. Release lever	See page 13
11. Speed control lever	See page 13
12. Throttle lever	See page 8
13. Electric Lift control switch *	See page 17
Cigarette lighter * (Not shown).	See page 18

* Optional Equipment

BEFORE OPERATING YOUR NEW TRACTOR

- Lubrication Lubricate the entire tractor. See pages 27 to 35.
- Tires Check the air pressure. See pages 20 and 21.
- Fuel system Fill the fuel tank with gasoline. See pages 9 and 10.

OPERATING THE ENGINE

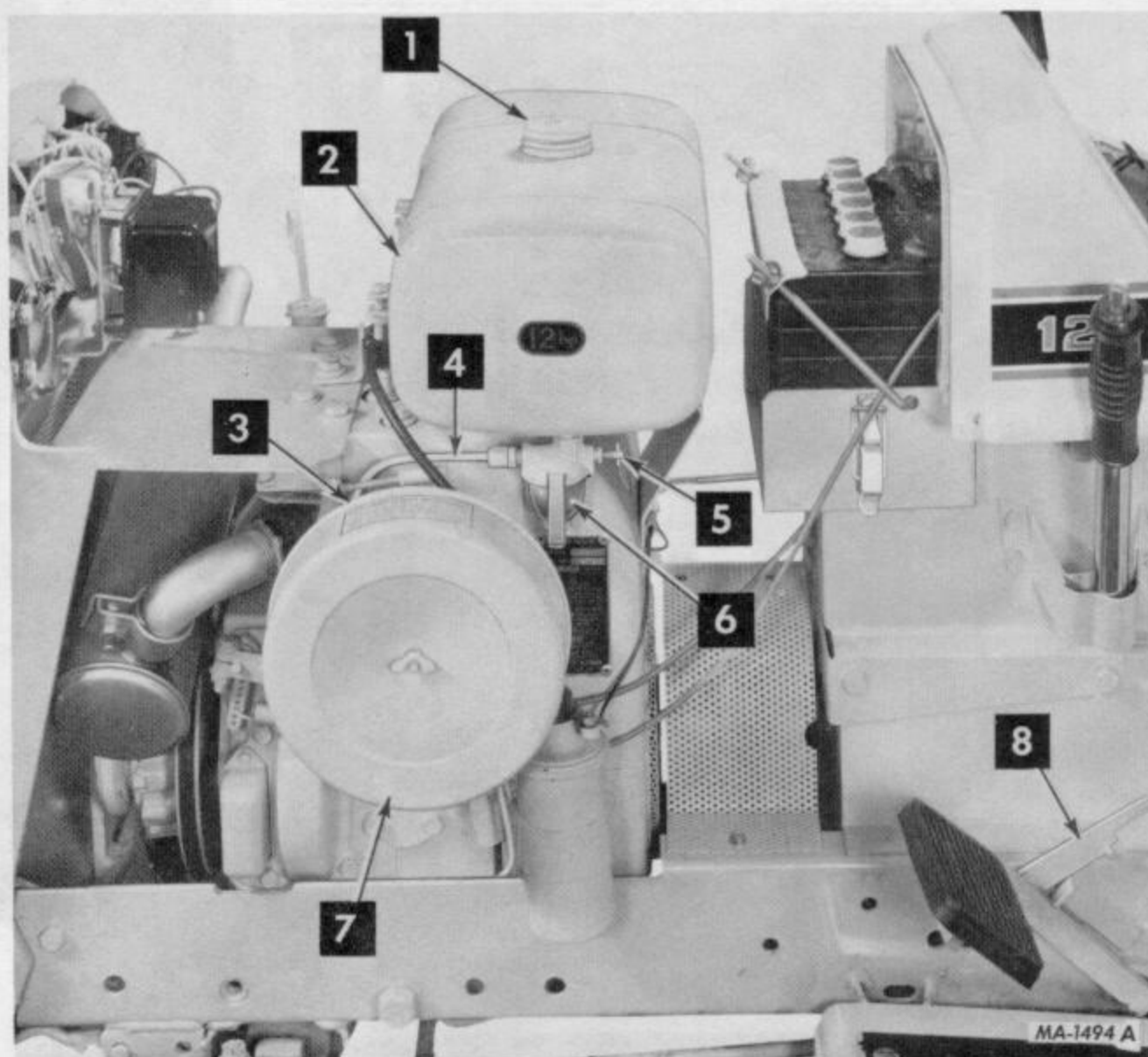

- 1. Fuel tank filler cap
- 2. Fuel tank
- 3. Carburetor (not seen)
- 4. Fuel line
- 5. Fuel shut-off valve
- 6. Fuel strainer
- 7. Air cleaner
- 8. Brake lock

Illust. 8
Fuel System

THROTTLE LEVER

This lever controls the speed of the engine. When set in a given position, it will maintain a uniform engine speed.

When using power take-off operated equipment, best performance is achieved with the throttle lever in the "Fast" position.

GOVERNOR

The governor is set at the time the engine is assembled and should not require readjustment unless the governor arm is removed or loosened from the governor shaft. Consult your International Harvester dealer if the

governor does not function properly.

LIFTING THE HOOD

The tractor hood is arranged to swing up and forward to make the engine and fuel tank readily accessible. To raise the hood on the International Cub Cadet 73 Tractor, take hold of each side of the hood at the rear, pull outward, and raise it upward and forward to its stop. On the International Cub Cadet 106, 107, 126, 127, and 147 Tractors unlatch the hood latches located at the rear of the hood and follow the same procedure of the International Cub Cadet 73 Tractor.

STARTING THE ENGINE

1. Be sure the fuel shut-off valve is open.
2. Pull the choke control button all the way out (see **Illust. 5 or 6**). More or less choking may be necessary due to variations in temperature, grade of fuel, etc. Little or none will be needed when the engine is warm.
3. Place the throttle lever halfway between "SLOW" and "FAST". See **Illust. 5 or 6**.
4. To start the engine the clutch-brake pedal must be pressed all the way down to activate the safety starting switch.

On the International Cub Cadet 107, 127, and 147 Tractors the speed control lever will return to neutral when the clutch brake pedal is pressed all the way down.

International Cub Cadet 73, 106, and 126 Tractors: Check to see that the gearshift lever is in the neutral position. See **Illust. 5**.

All Models: Turn the ignition key clockwise to the "START" position and release it as soon as the engine starts; however do not operate the motor-generator for more than 30 seconds at any one time. If the engine does not start within this time, turn the key "OFF" and wait a few minutes, then try again.

5. After the engine starts, slowly release the clutch-brake pedal and gradually push the choke control button all the way in. Do not use the choke to enrich the fuel mixture, except when necessary to start the engine.

STOPPING THE ENGINE

Move the throttle lever to the "SLOW" position and allow the engine to idle for a short time before stopping. Then turn the key to the "OFF" position.

FUEL SYSTEM

FUEL SYSTEM

Fill the fuel tank with clean, fresh, regular grade gasoline, preferably at the end of each day's use. This will force out any moisture-laden air and prevent condensation in the fuel tank. Do not mix oil with the gasoline.

The fuel tank filler cap has an air vent. Keep the vent open at all times to assure proper flow of the fuel.

Caution! Never remove the fuel tank cap or fill the fuel tank when the engine is running, is hot, or when near an open flame. Do not smoke when working around inflammable fuel, as the air around the tractor is mixed with a highly explosive vapor. When pouring fuel, keep the container or hose nozzle in contact with the metal of the fuel tank to avoid the possibility of an electric spark igniting the gas. Do not spill gasoline on a hot engine.

FUEL SHUT-OFF VALVE

Be sure the shut-off valve on the fuel strainer under the gasoline tank is open. Screw out the needle stem (Shut-off valve) until the seat on the stem is tight against the

stop to prevent leakage or seepage when the valve is in its full-open position.

CLEANING THE FUEL STRAINER AND SEDIMENT BOWL

After every 25 hours of operation, clean the fuel strainer as follows:

1. Close the shut-off valve. See **Illusts. 10 and 10A**. Loosen the knurled nut under the sediment bowl and remove the bowl and screen.
2. Clean the sediment bowl and screen.
3. When reassembling, be sure the gasket between the bowl and the main body is in good condition and does not leak. Use a new gasket if necessary.

CARBURETOR ADJUSTMENTS

The carburetor is adjusted at the factory and under normal operating conditions it will not require readjusting. However, if the engine does not operate properly, it is recommended a new air cleaner be installed before performing carburetor adjustments. If this adjustment has been disturbed for any reason, proceed as follows:

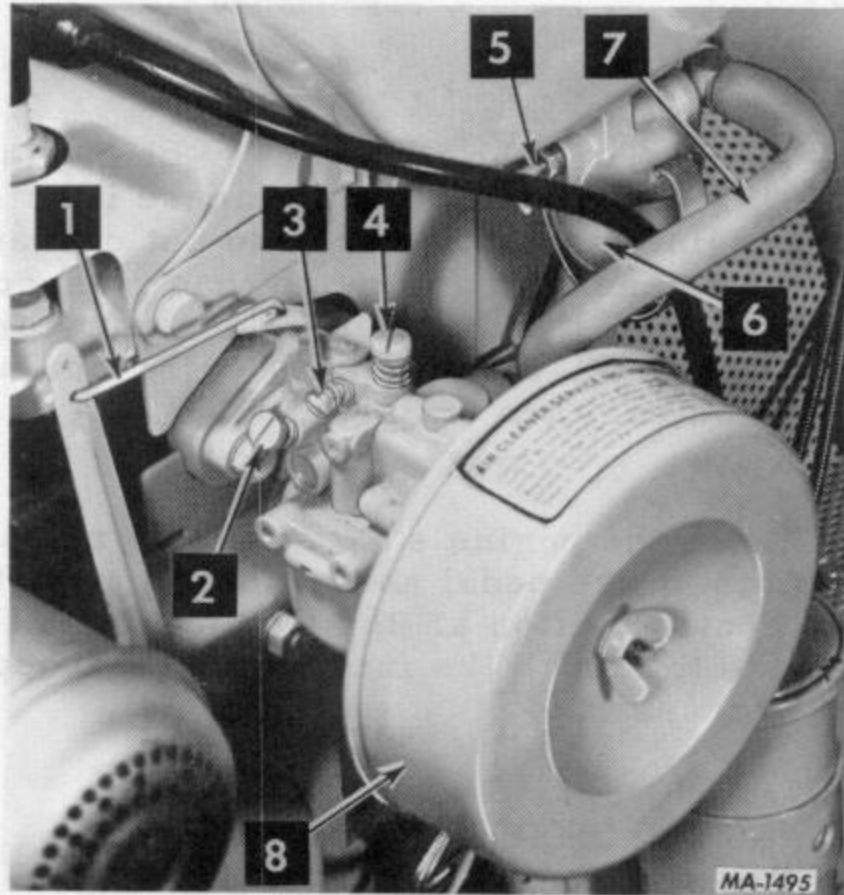

1. Governor control rod
 2. Idle adjustment screw
 3. Throttle stop screw
 4. High speed adjustment screw

Illust. 10
 (International Cub Cadet 73 Tractor)

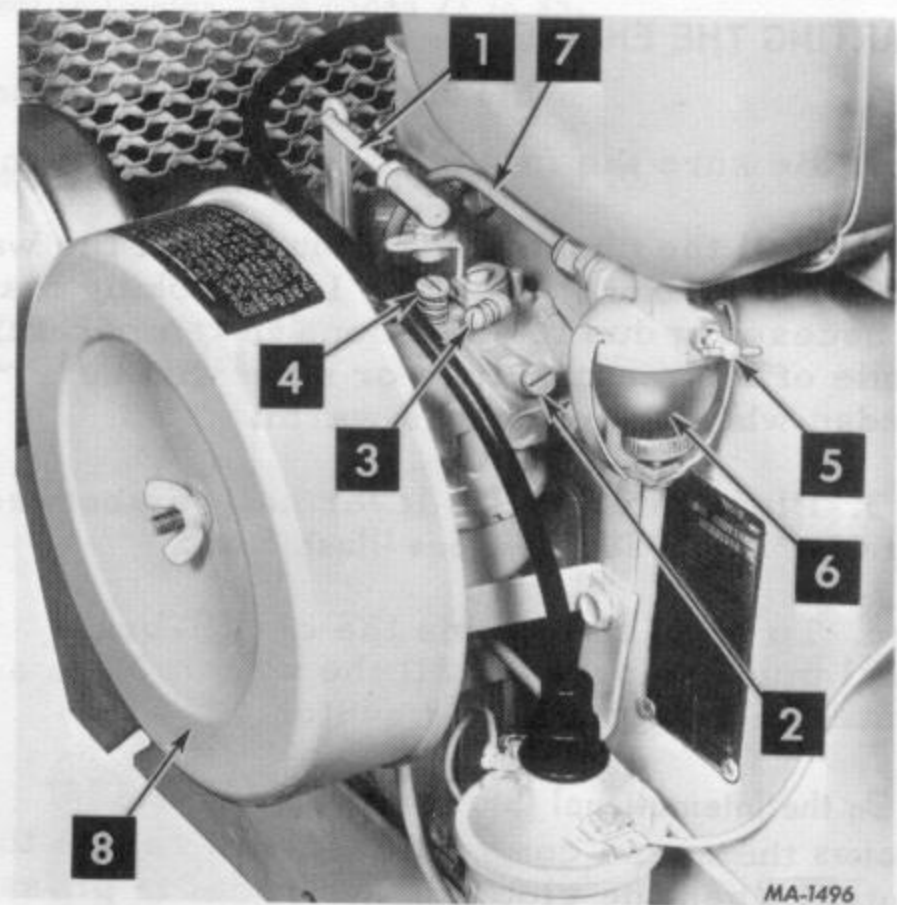

5. Fuel shut-off valve
 6. Sediment bowl
 7. Fuel line
 8. Air cleaner

Illust. 10A
 (International Cub Cadet 106, 107, 126, 127,
 and 147 Tractors)

Carburetor and fuel strainer

Adjusting the Idle Adjustment Screw

After the high speed adjustment screw is adjusted, it may be necessary to readjust the idle adjustment screw (Illusts 10 and 10A), as each affects the other.

Close the idle adjustment screw to its seat by turning it clockwise; then open it one turn. Start the engine and operate it at fast idling speed (without any load) until thoroughly warm.

While the engine is running at fast idle speed, it is advisable to screw in the throttle stop screw (Illusts. 10 and 10A) a few turns to keep the engine from stopping when the throttle lever is moved to the fully retarded "SLOW" position. The engine will then be idling at a fairly high speed and the throttle stop screw can be backed out a little at a time until the desired idle speed is obtained.

If the engine misses or rolls while backing out the throttle stop screw, the idle adjustment screw may be adjusted in or out until the engine operates smoothly. Speed up the engine for a few seconds; then recheck the idle adjustment. A slight adjustment in or out will give the smoothest idle.

Adjusting the High-Speed Adjustment Screw

Turn the high speed adjustment screw (Illusts. 10 and 10A) counter-clockwise approximately two turns from the closed position and start the engine.

After the engine has reached normal operating temperature, accelerate the engine and check its response.

Place the engine under load and turn the high speed adjustment screw (Illusts. 10 and 10A) to the leanest mixture that will allow satisfactory acceleration and steady governor operation.

If the engine misses and backfires under load, the high speed mixture is too lean. The high speed adjustment screw must be turned counter-clockwise 1/4 turn at a time until the condition is corrected.

If the engine shows a sooty exhaust and is sluggish under load, the high speed mixture is too rich. The high speed adjustment screw must be turned clockwise 1/4 turn at a time until the condition is corrected.

DRIVING THE TRACTOR

PREPARING THE TRACTOR FOR EACH DAY'S WORK

Check the crankcase oil level and add new oil if necessary. See page 27.

Clean the air cleaner element if necessary. See page 17.

Inspect the tires for general condition. See pages 20 and 21.

ADJUSTING THE SEAT

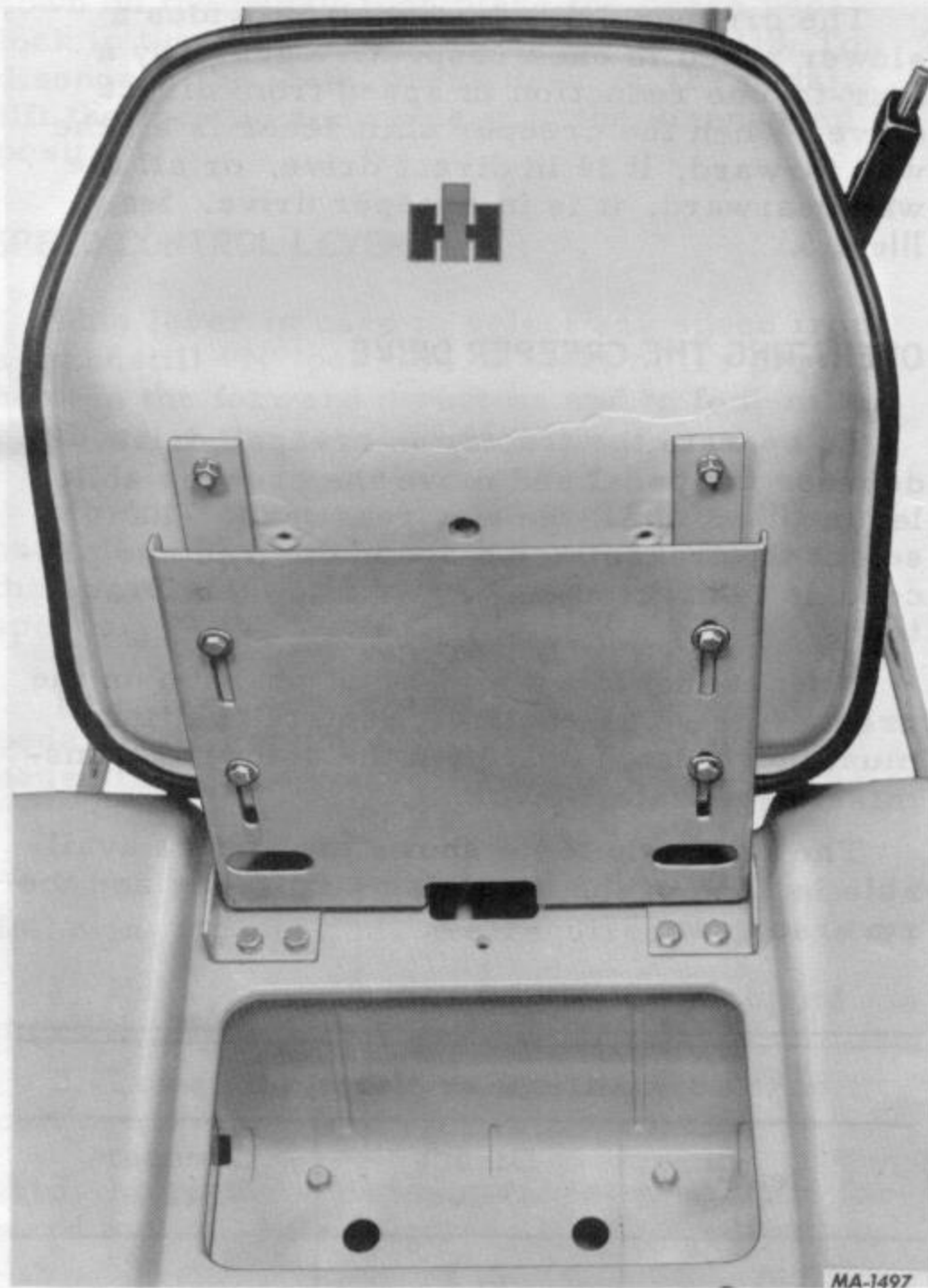

Illust. 11
Adjusting the seat.
(International Cub Cadet 106, 107, 126, 127, and 147 Tractors)

Before starting the tractor, adjust the seat to the most comfortable driving position by loosening the four cap screws in the seat sup-

port (Illust. 11) or seat spring clamping plate (Illust. 11A) and slide the seat assembly forward or rearward to the position which is most comfortable for the operator.

Retighten the cap screws after the seat is adjusted.

The International Cub Cadet 106, 107, 126, 127, and 147 Tractors features a seat which can be tilted forward over the steering wheel, for convenience in adjusting the seat and access to the tool box. See Illust. 11.

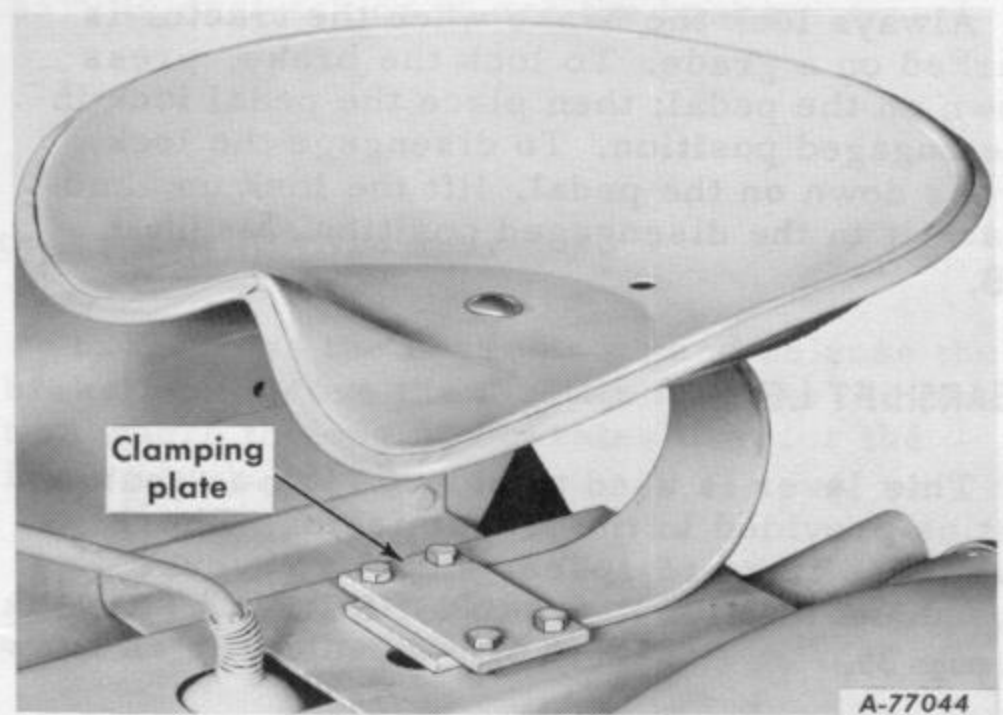

Illust. 11A
Adjusting the seat
(International Cub Cadet 73 Tractor)

CLUTCH AND BRAKE PEDAL

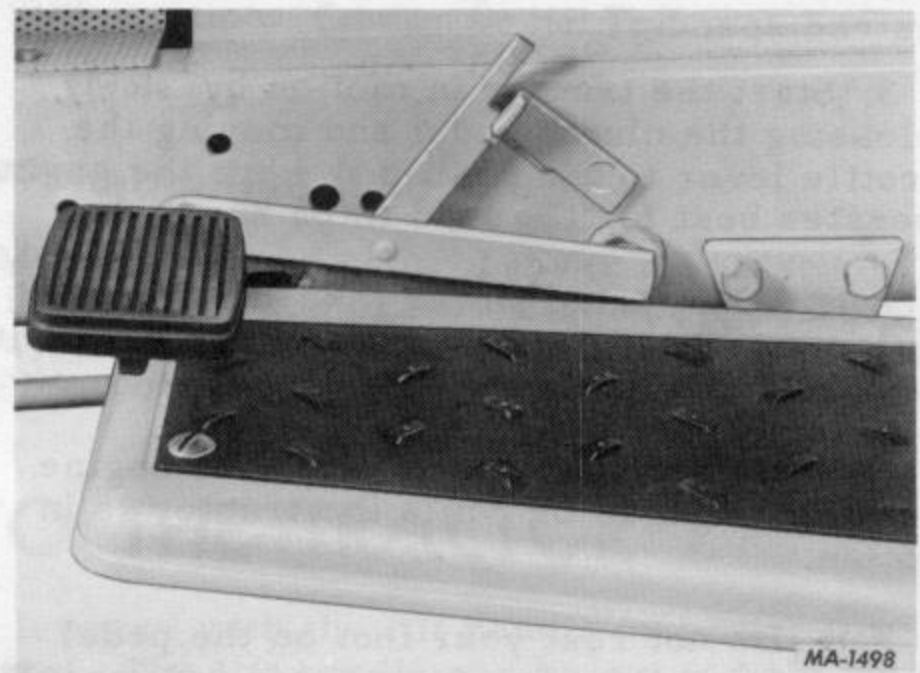

Illust. 11B
Brake pedal lock in the engaged position.

DRIVING THE TRACTOR

International Cub Cadet 73, 106 and 126 Tractors

CLUTCH-BRAKE PEDAL

The combination clutch-brake pedal is used to disengage the engine from the transmission when shifting gears and to actuate the brake to stop the tractor. The pedal must be pressed all the way down to activate the safety starting switch when starting the engine.

To disengage the clutch, and apply the brake, press the pedal all the way down.

LOCKING THE BRAKE

Always lock the brake when the tractor is parked on a grade. To lock the brake, press down on the pedal; then place the pedal lock in the engaged position. To disengage the lock, press down on the pedal, lift the lock up, and place it in the disengaged position. See *Illust. 11B*.

GEARSHIFT LEVER

This lever is used to select various gear ratios provided in the transmission. There are three forward speeds and one reverse speed. See *Illust. 5*. Refer to "SPECIFICATIONS" on page 35.

STARTING THE TRACTOR

1. Advance the throttle lever slightly. See *Illust. 5*.
2. Disengage the clutch by pressing the clutch pedal all the way down, and release the brake lock. Move the gearshift lever to the desired speed.
3. Start the tractor in motion by slowly releasing the clutch pedal and moving the throttle lever to the position where the engine operates best for the load to be handled.

Note: When using power take-off operated equipment, best performance is achieved with the throttle lever in the "Fast" position.

Note: Do not shift gears while the engine clutch is engaged or while the tractor is in motion.

Note: Do not rest your foot on the pedal while driving the tractor, as this will result in excessive clutch lining wear.

Always be sure the rear wheels are free to turn. Under any adverse conditions, do not attempt to free the tractor by speeding up the engine and suddenly engaging the clutch. Try backing out instead of going forward.

STOPPING THE TRACTOR

Disengage the clutch by pressing the pedal all the way down. Move the gearshift lever to the "N" position. Before dismounting always lock the pedal, disengage the power take-off, and turn the ignition "OFF".

CREEPER SHIFT LEVER

The creeper drive (optional) provides a slower speed in each respective gear, by a four-to-one reduction in speed from direct drive. When the creeper shift lever is all the way forward, it is in direct drive, or all the way rearward, it is in creeper drive. See *Illust. 5*.

OPERATING THE CREEPER DRIVE

To operate the tractor in creeper drive, depress the pedal and move the creeper shift lever (*Illust. 5*) all the way rearward. Then select the transmission speed desired and proceed as instructed under "Starting the Tractor".

Note: Do not use a mid-point position on the creeper drive as neutral. Neutral position must be selected only with the standard transmission gearshift lever.

The following table shows the speeds available in each of the three forward gears and the reverse gear.

SPEED TABLE

Miles Per Hour		
Gear	Direct Drive	Creeper Drive
First	2.3	.6
Second	3.9	1.0
Third	6.8	1.7
Reverse	2.5	.6

DRIVING THE TRACTOR

(International Cub Cadet 107, 127, and 147 Tractors)

BRAKE PEDAL

The brake pedal must be pressed all the way down to activate the safety starting switch. When the brake pedal is in the depressed position it automatically moves the speed control lever to the "N" position.

The tractor can be stopped either by pressing the pedal all the way down, or placing the speed control lever in the "N" position.

LOCKING THE BRAKE

Always lock the brake when dismounting from the tractor. To lock the brake, press down on the pedal; then place the brake pedal lock in the engaged position. See *Illust. 11B*. To disengage the lock, press down on the pedal, lift the lock up and place it in the disengaged position.

SPEED CONTROL LEVER

This lever is used to select any speed from a standstill "N" position to eight miles per hour in the forward direction and to four miles per hour in the reverse direction.

Moving the speed control lever forward provides increased forward speed, and moving the lever rearward provides the reverse speeds.

Note: Do not rest your foot on the brake pedal while driving the tractor as this would cause the speed control lever to return to the "N" position.

Note: On tractors with a rotary tiller the following instructions are required.

1. Engage the Power Take-Off clutch, and move the throttle to "Fast".
2. Lower the rotary tiller to the desired cutting depth.
3. Move the speed control lever to start forward motion. **Note:** In rotary tilling application,

the tractor is used to hold the rotary tiller back rather than to pull the unit, as in plowing or mowing.

4. Move the speed control lever back to a position to maintain proper mulching of the soil.

5. With a hydrostatic drive, it may be necessary to vary the speed control lever as the soil conditions vary. With a gear driven tractor, under similar conditions, it may be necessary to declutch or to use the brake.

STARTING THE TRACTOR

1. Depress the brake pedal and release the brake lock. Move the throttle lever to the position where the engine operates best for the load to be handled.

2. Start the tractor in motion by moving the speed control lever slowly forward or rearward as described above.

RELEASE LEVER

To push or move tractor for a short distance or when working on the engine, the release lever (*Illust. 7*) must be locked in the release (up) position and the speed control lever must be in the "N" position. **Caution: Do Not Tow.**

STOPPING THE TRACTOR

Move the speed control lever to the "N" position or use the brake. Before dismounting always lock the pedal, and turn the ignition "OFF".

HITCHING EQUIPMENT TO THE TRACTOR

Drawbar equipment **must** be hitched to the tractor **only** at the hitch hole in the drawbar. See *Illusts. 14 and 14A*.

When the tractor has a three-point hitch (*Illusts. 14 and 14A*) equipment adaptable is raised

and lowered with the lift handle or power lift control. The lift handle can be set to hold the equipment at various positions by use of the six notches in the lift handle quadrant. The lower mounting bracket has three holes which are used for additional adjustment.

HITCHING EQUIPMENT TO THE TRACTOR

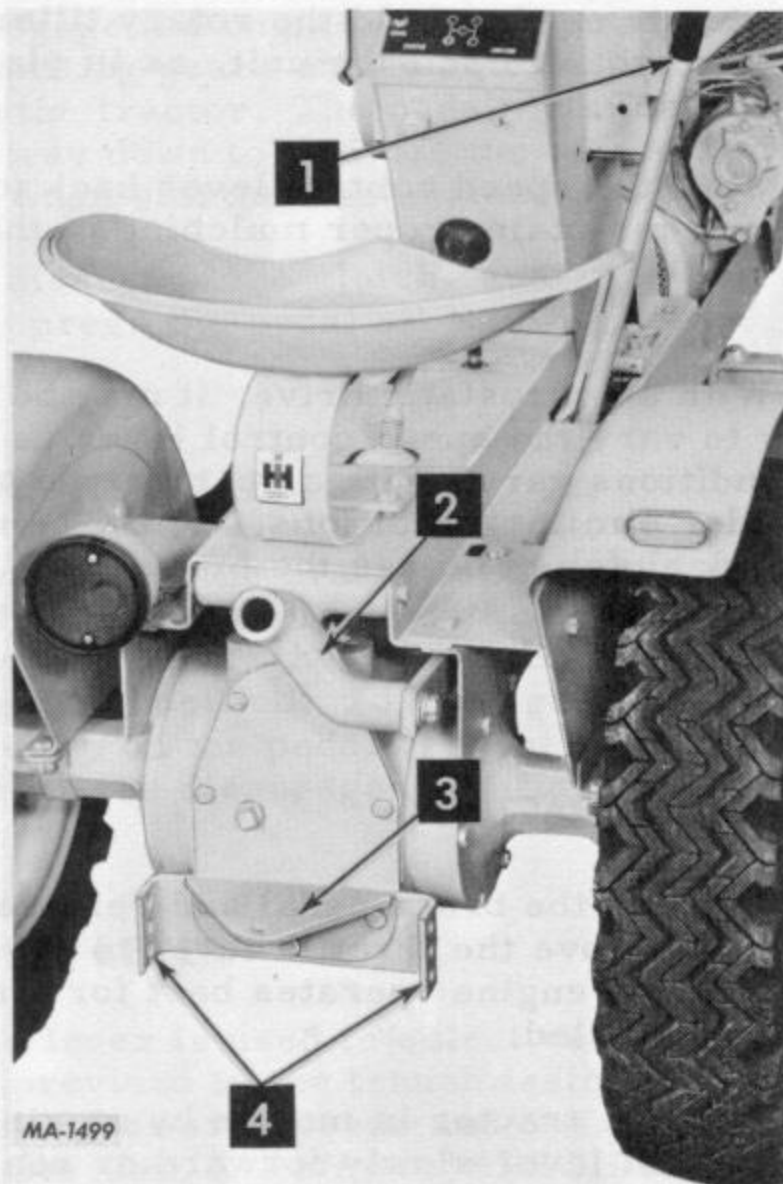

1. Lift handle
2. Lift lever
3. Drawbar
4. Three-point hitch

Illust. 14
Drawbar and three-point hitch
shown on International Cub Cadet 73 Tractor.

The lift handle is used to lift or lower equipment used with the tractor. The equipment can be set in various positions by depressing the button on the top of the handle and releasing it when the desired position is reached.

To operate equipment in the "FLOAT" position, depress the release button on top of the handle, press in the lock button located at the front of the handle and release the top button. **See Illust. 14A.**

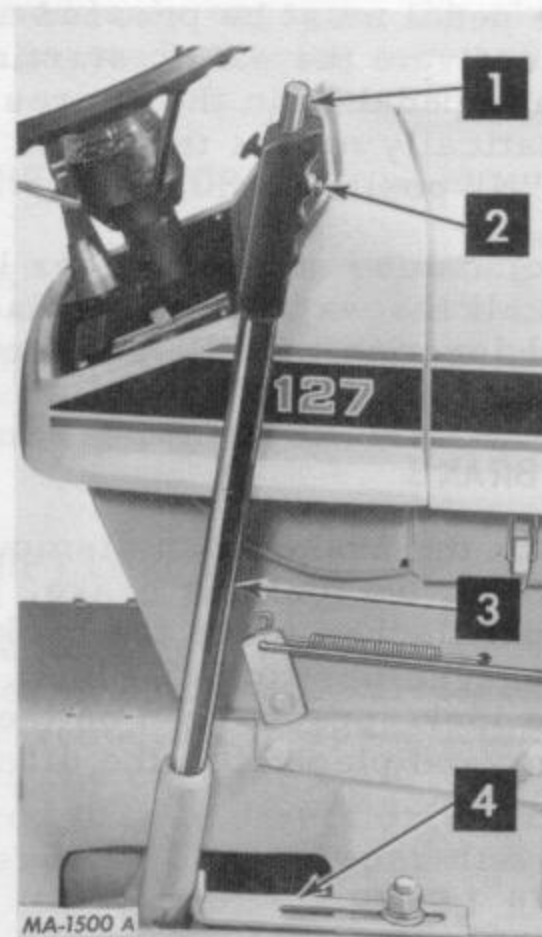

1. Release button
2. Lock button
3. Lift handle
4. Lift handle stop

Illust. 14A
Adjustable stop limiting handle travel.

Note: To disengage the lift handle from the float position, pull lift handle back slightly and depress top button.

When the equipment is allowed to float, the forward position of the lift handle can be limited by the adjustable stop. Loosen the nut, slide the stop to the required position, and tighten the nut. **See Illust. 14A.**

Refer to the equipment manual for proper hitching instructions.

FRONT QUICK-ATTACHING LATCH

This latch (Illust. 21) is used for front and center mounted equipment. Refer to the equipment manual for proper instructions.

REAR POWER TAKE-OFF

International Cub Cadet 73, 106 and 126 Tractors

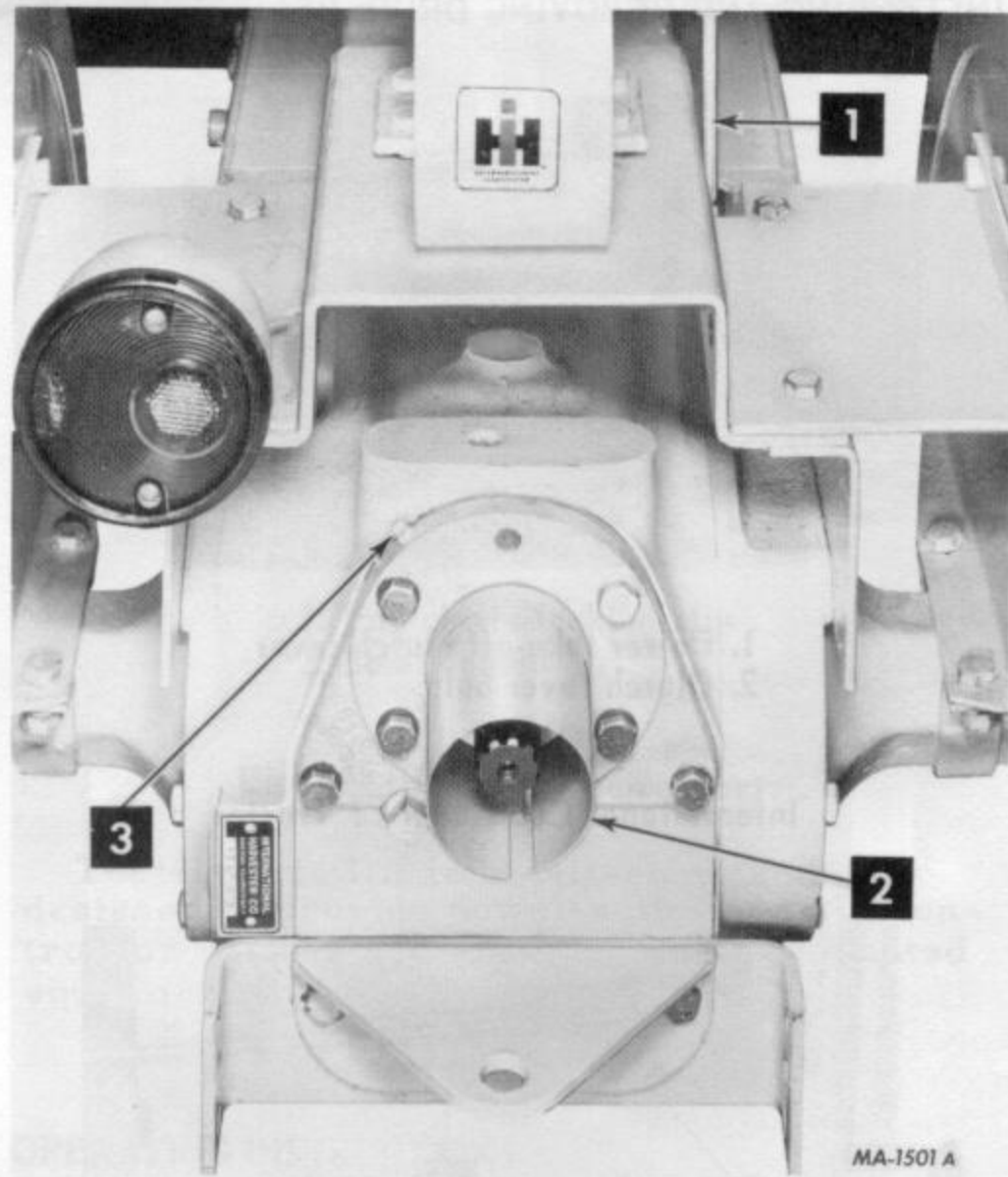

1. Shifter rod
2. Power take-off guard
3. Grease fitting

Illust. 15
International Cub Cadet 73 Tractor

If your tractor is equipped with a rear power take-off, the following instructions should be carefully studied and followed.

The rear power take-off is started and stopped by the same engine clutch as the tractor. Be sure to disengage the engine clutch before moving the power take-off shifter rod (Illust. 15) or shifter lever (Illust. 15A).

Caution! The shifter rod should always be in the disengaged (forward) position or the shifter lever in the disengaged (rearward) position when the power take-off is not in use. Always cover the power take-off exposed shaft with the guard when the power take-off is not being used.

OPERATING THE REAR POWER TAKE-OFF WITH THE TRACTOR STANDING STILL

1. Move the throttle lever back to the "SLOW" speed.



1. Shifter lever

Illust. 15A
International Cub Cadet 106 and 126 Tractors

2. Depress the pedal and move the transmission gearshift lever to the neutral position.

3. **On the International Cub Cadet 73 Tractor:** Press down on the shifter rod (Illust. 15) and move it rearward to the engaged position. Then release the shifter rod and allow it to lock in place.

On the International Cub Cadet 106 and 126 Tractors: Move the shifter lever (Illust. 15A) forward to the engaged position.

4. Move the throttle lever toward the "FAST" position and slowly release the pedal.

OPERATING THE REAR POWER TAKE-OFF WITH TRACTOR IN MOTION

Follow steps 1 thru 3 outlined above. Keep the pedal depressed, move the transmission gearshift lever to the speed desired and advance the throttle lever. Slowly release the clutch pedal. This will start the tractor in motion with the power take-off in operation.

FRONT POWER TAKE-OFF

OPERATING THE FRONT POWER TAKE-OFF CLUTCH

1. Move the throttle lever back to the medium or "slow" position.
2. Move the control lever forward slowly to the engaged position. See *Illust. 5 or 6*.
3. Advance throttle to operating speed.

Note: The control lever should always be placed in the forward or engaged position when the tractor is being used without front power take-off equipment.

ADJUSTING THE CLUTCH RELEASE LEVER

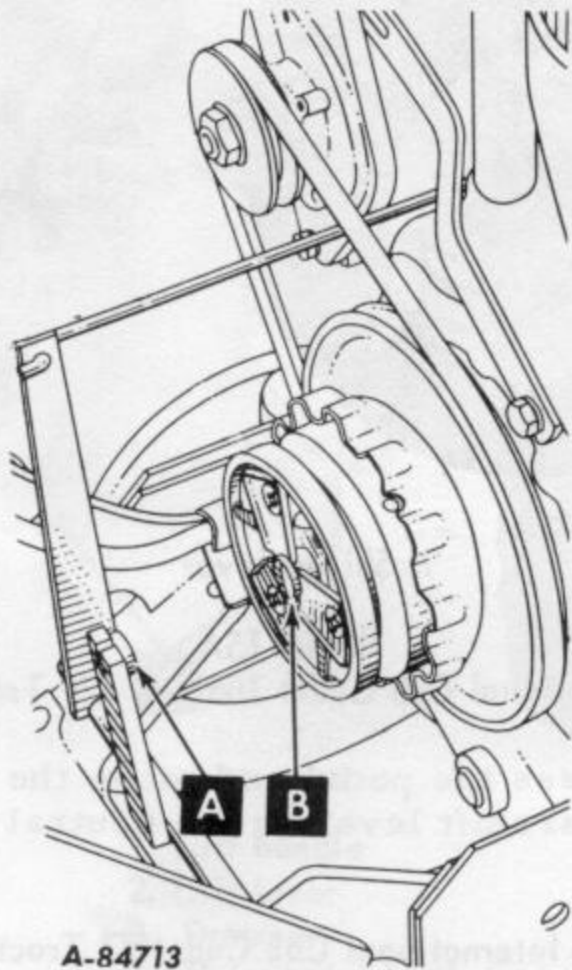

Illust. 16

View with grille removed to show engaging lever wear button and pressure spring thrust button.

The clutch is factory adjusted and should not require further adjustment under normal operating conditions. However, if clutch slippage should occur, see your International Harvester dealer.

After considerable use, it may be necessary to readjust the button clearance as described below to assure proper clutch engagement.

With the clutch fully engaged (clutch lever in the forward position) place a piece of thin cardboard (match book cover) approximately 1/64-inch thick between the engaging lever wear button "A" and the pressure spring thrust button "B" (*Illust. 16*), loosen the jam nut on the clutch lever turnbuckle, and adjust the turnbuckle until a light drag is felt on the cardboard when it is removed from between the buttons. Be sure all slack, except the 1/64-inch adjustment, is out of the linkage. Then, tighten the jam nut securely against the turnbuckle.

INSTALLING AND REMOVING DRIVE BELT

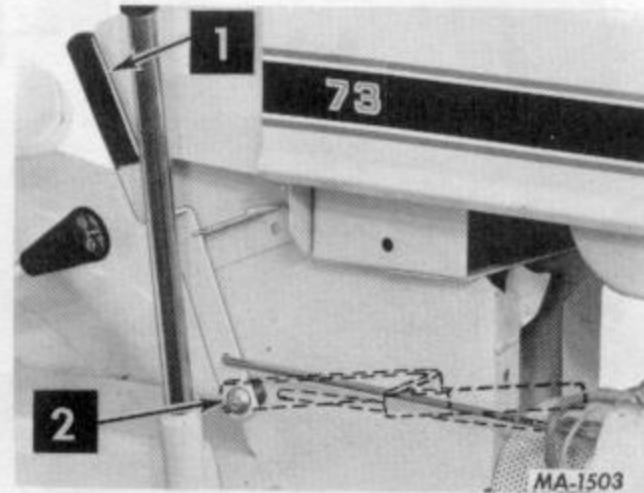

1. Power take-off clutch lever
2. Clutch lever bolt

Illust. 16A
International Cub Cadet 73 Tractor

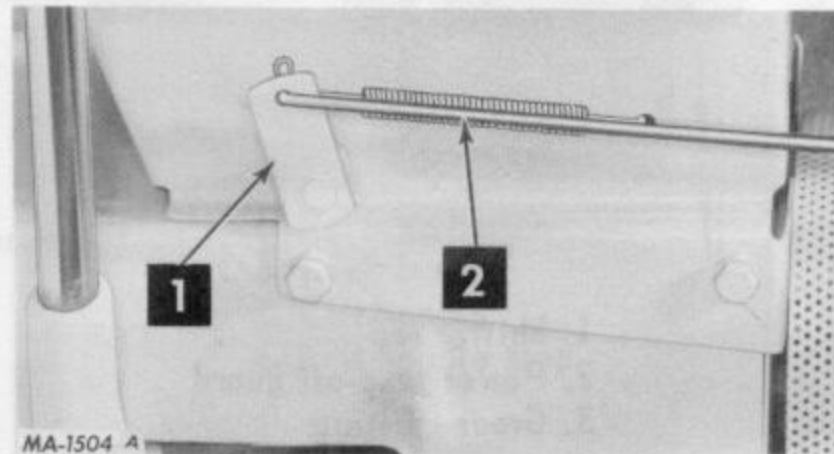

1. Clutch lever bracket
2. Clutch lever rod

Illust. 16B
International Cub Cadet 106, 107, 126, 127, and 147 Tractors

For the International Cub Cadet 73 Tractor, loosen the clutch lever bolt (*Illust. 16A*) so the lever can be moved forward to a horizontal position.

For the International Cub Cadet 106, 107, 126, 127 and 147 tractors, disconnect the clutch lever rod from the bracket. See *Illust. 16B*.

The above procedure will provide sufficient clearance between the engaging lever wear button "A" and the pressure spring thrust button "B" to install or remove the drive belt. See *Illust. 16*.

After installing a new belt, move the clutch lever back onto the clutch lever latch and tighten the bolt, (*Illust. 16A*), or reattach the clutch lever rod to the bracket, (*Illust. 16B*) depending on the model tractor you have. Check button clearance and adjust if necessary.

ELECTRIC LIFT

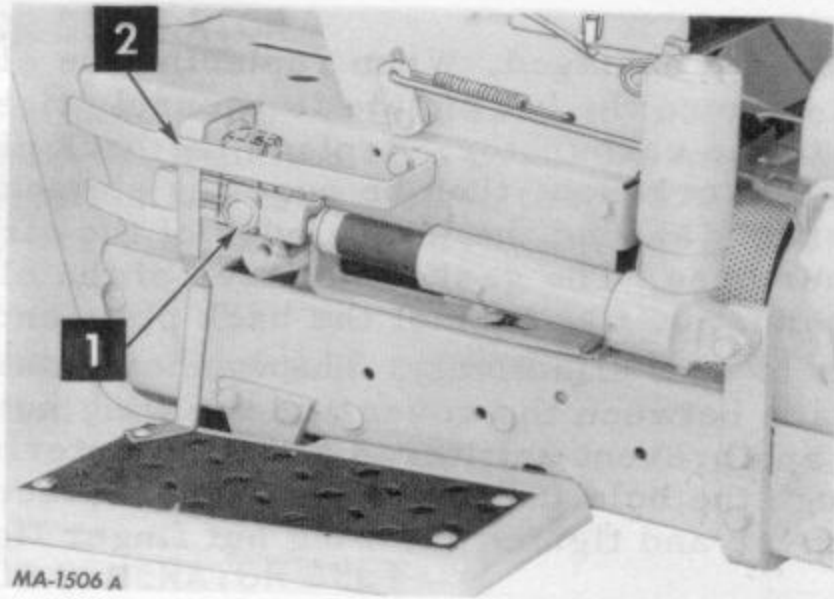

1. End clevis locking clip
2. Safety guard

Illust. 17
Electric lift assembled on tractor.

The electric lift is a self-contained unit designed to provide power with fingertip control for raising and lowering center mounted equipment.

OPERATING INSTRUCTIONS

The electric lift is operated by a control switch located on the upper righthand corner of the instrument panel. To raise the implement push upward on the control switch until the desired height is reached, then release the

switch. The switch will return to the center or neutral position. The equipment will "hold" in whatever position desired when you release the control switch. To lower the equipment push down on the control switch. The switch will again return to the center or neutral position when you release it.

Note: Always operate the electric lift with the tractor engine running. Operation of the electric lift off of the battery only will cause premature battery failure.

Caution! Whenever raising or lowering equipment release the control switch when the equipment has reached a fully raised or lowered position. Not doing so can result in damage to the electric circuits.

Note: Never operate the electric lift with the safety guard removed.

To operate equipment in "rigid" position, the end clevis locking clip must be in the locked position as shown in Illust. 17.

To operate equipment such as a mower in "float" position, raise the end clevis locking clip to the unlocked position. See Illust. 17.

ENGINE COOLING AND AIR CLEANER

ENGINE COOLING

This tractor has an air cooled engine. Air must be able to circulate freely around the engine, through the screen and shroud, and over the fins of the cylinder head and cylinder block. Keep these areas free of accumulated dirt and trash or the engine will overheat and result in damaged moving parts. Periodic cleaning with compressed air will keep this area clear for adequate cooling.

DRY TYPE AIR CLEANER

Incoming air for combustion is filtered by a dry-type air cleaner having a filter element inside of the cover.

Remove and clean or replace the element with a new one when loss of power is noticeable. Replace at least once a year.

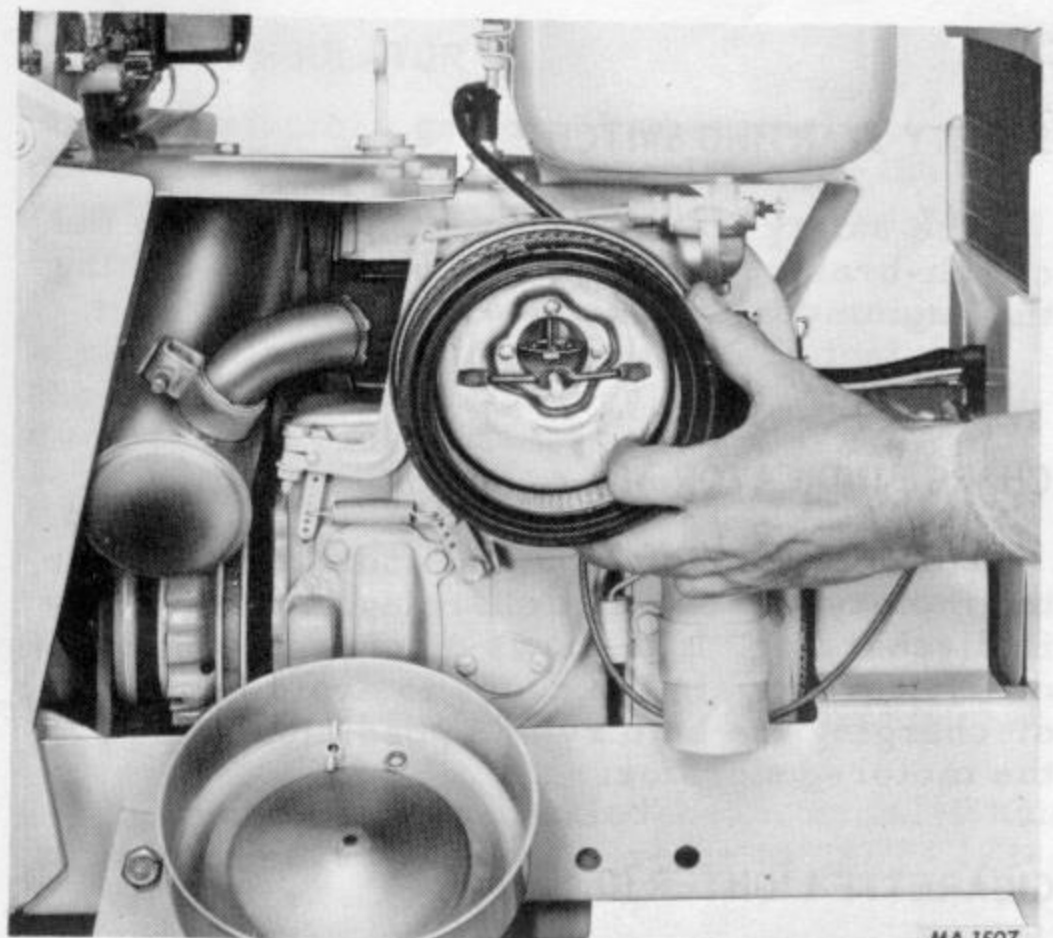

Illust. 17A
Removing the air cleaner filter element.

ENGINE COOLING AND AIR CLEANER

Cleaning the Element

To clean the element, remove the wing nut, washer, and air cleaner cover (Illustr. 17A) then remove the element and tap it lightly on a flat surface to cause the loose dirt to fall off. Handle the paper element with care to avoid perforations. Do not use compressed air to remove the dirt as this can rupture the element. Do not wash or use a solvent.

Replacing the Element

Replace the element with a new one if dirt does not drop off easily, or if it is bent,

crushed or damaged. When replacing the element be sure the back plate is securely tightened to the carburetor. Replace the back plate if bent or cracked, then be sure the element fits snugly around the inside edge of the air cleaner base. The gasket surfaces of the element must be flat against the back plate and cover to seal effectively. The washer must be in place between the cover and the wing nut to seal and prevent unfiltered air from entering through the hole in the cover. Then replace the cover and tighten the wing nut finger tight.

ELECTRICAL SYSTEM

The twelve-volt electrical system consists principally of a motor-generator, voltage regulator, and a twelve-volt battery.

All connections must be clean and securely fastened.

IGNITION SWITCH

Turn the key clockwise to turn on the ignition. A further turn actuates the motor-generator. The key cannot be removed when in the "ON" position.

Note: When the engine is not operating the key must be turned to the "OFF" position to prevent battery discharge.

SAFETY STARTING SWITCH

The safety starting switch, activated by the clutch-brake pedal, serves to prevent starting the engine accidentally.

CHARGE INDICATOR

This instrument (Illustr. 6) indicates whether the motor-generator is charging or the battery is discharging. If it shows discharge continuously, investigate the cause to avoid completely discharging the battery and possible damage to the motor-generator.

CIGARETTE LIGHTER (Optional)

Push the lighter to make electrical contact. When it pops back it is ready for use.

SPARK PLUG

Note: Remove all dirt from around the spark plug before removing.

Remove the spark plug, always using a spark plug wrench, after every 100 hours of operation to check the gap. See Illustr. 18.

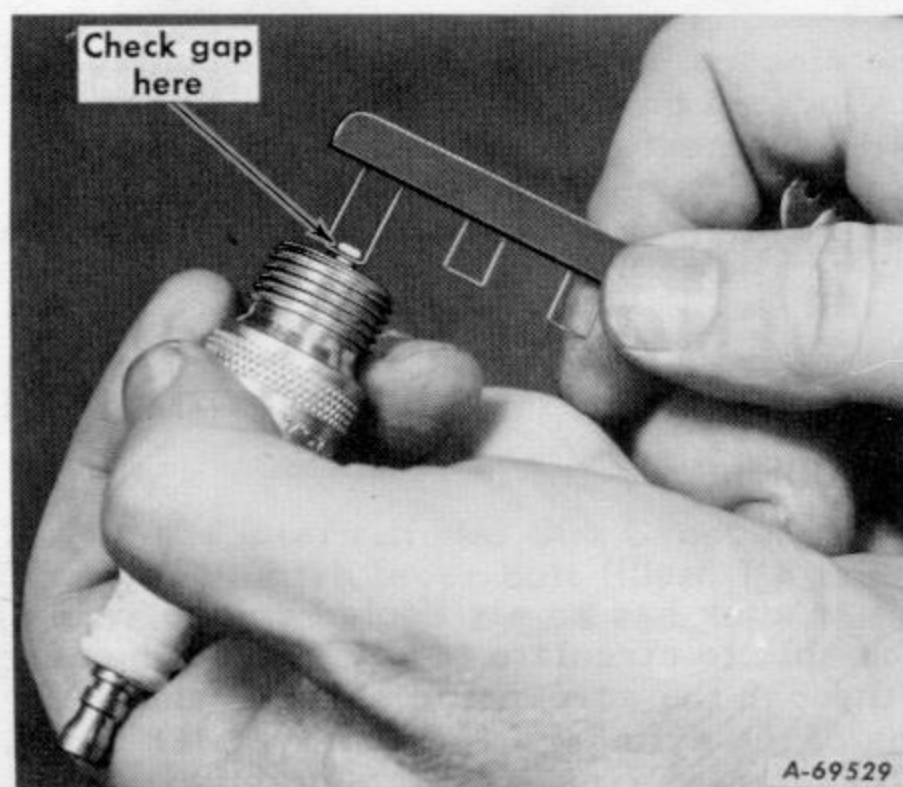

Illustr. 18
Checking the spark plug gap.
Set gap at .025-inch.

Be sure the gasket is in good condition. Tighten the plug 1/2 to 3/4 turns past finger tight.

Replace a defective plug with a new plug. See your International Harvester dealer for a correct replacement plug.

ELECTRICAL SYSTEM

MOTOR-GENERATOR

The motor-generator (12-volt, negative ground) will function as a cranking motor when the ignition key is turned to the "START" position, driving the engine by means of a belt.

When the engine is operating, the unit will function as a generator.

MOTOR-GENERATOR BELT

Check the tension of the motor-generator belt after the first 10 hours of operation and every 50 hours of operation thereafter. The tension is correct when the belt can be deflected a maximum of 1/4-inch by a ten pound force applied midway between the two pulleys.

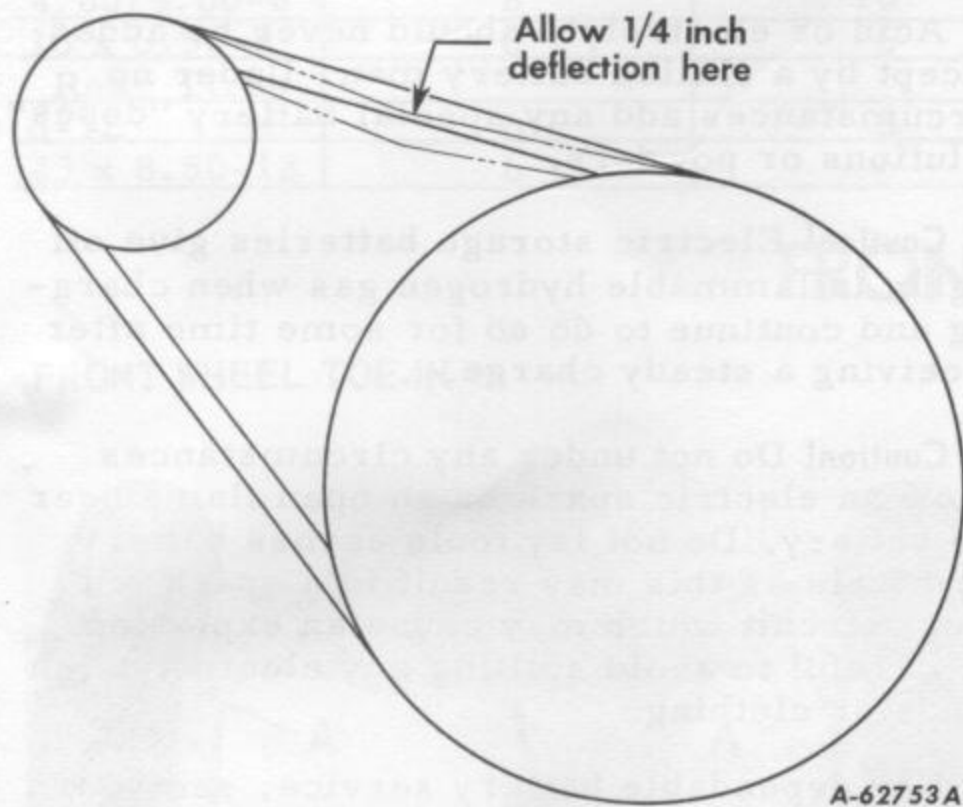

Illust. 19

Correct motor-generator belt tension.

Also follow this procedure when a new belt is installed.

Adjusting the Motor-Generator Belt

Loosen the motor-generator brace bolt and mounting bolts, Illust. 19A

Move the generator away from the engine until the tension on the belt is correct. See Illust. 19.

Note: Under no circumstances should a pry bar be used on the motor-generator to obtain belt tension as damage to the bearings will result.

Tighten mounting bolts and brace bolt.

Removing and Replacing the Motor-Generator Belt

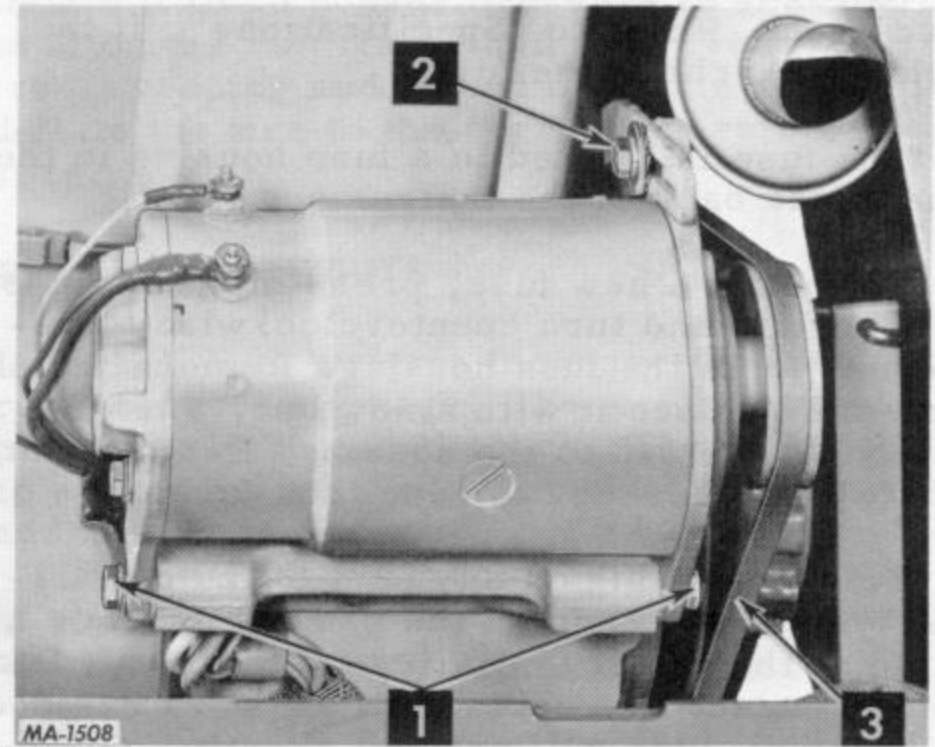

1. Mounting bolts
2. Motor generator brace bolt
3. Motor generator belt

Illust. 19A

Replace the motor-generator belt when it becomes badly worn. To remove the old belt, loosen the motor-generator brace bolt and mounting bolts (Illust. 19A). Move the generator in toward the engine and slip the old belt off the pulleys and over the crankshaft. Install the new belt in the reverse order of removal and adjust the belt to the proper tension.

Note: If tractor is equipped with rotary mower, drive belt must also be removed when replacing generator belt. See page 16.

VOLTAGE REGULATOR

A satisfactory generator charging rate is maintained by the voltage regulator. If the regulator fails to operate correctly, see your International Harvester dealer.

Note: Never place a jumper lead between, or accidentally bridge, the "BAT" terminal and the "F" terminal on the regulator, as this will damage the regulator.

LIGHTS

Lights are optional on all models except the 147.

The light switch is a push-pull control. See Illust. 6

The headlights are sealed-beam units. When replacement is necessary, refer to "SPECIFICATIONS".

To replace the taillight lamp, remove the lens from the taillight and replace. Refer to "SPECIFICATIONS".

ELECTRICAL SYSTEM

FUSE (Electric Lighting)

Always use the same capacity fuse for replacement. Refer to "Specifications". If the lights fail, check the fuse.

The fuse is located in a fuse housing in the line at the back of the instrument panel.

To install a new fuse, press in on the fuse housing cap and turn counterclockwise to remove it from the fuse housing. Remove the old fuse and replace it with a new one. Then reassemble the cap to the housing. Remove the battery if necessary to reach the fuse.

Before working on any part of the electrical system, disconnect the battery ground cable at the battery negative (-) terminal. Do not reconnect this cable until all work has been completed. This will prevent shorting and damage to any of the electrical units. Examine the electrical cables occasionally to be sure they are not being frayed by contact with adjacent parts.

When replacing a battery, make certain the ground cable is connected to the negative (-) terminal on the battery. Be sure the rubber boot is properly positioned over the positive (+) terminal on the battery. **Note:** Both cables must be assembled with the nuts to the inside of the terminals to prevent shorting against the pedestal.

Cleaning and Servicing the Battery

Occasionally remove the battery cables and brighten the terminal contact surfaces with wire wool, and reassemble them. Apply a

light coat of vaseline or chassis lubricant. Be sure the terminals are clamped tightly and that the battery is fastened securely in the battery box. Replace unserviceable cable. Keep the vent holes in the battery filler caps open.

Keeping the battery fully charged not only adds to its life but makes it available for instant use when needed.

Liquid Level

Check the battery at least once a month for water level.

The electrolyte (acid and water) in each cell should be at ring level at all times to prevent battery failure. When the electrolyte is below this level, add pure, distilled water.

Acid or electrolyte should never be added except by a skilled battery man. Under no circumstances add any special battery "dopes", solutions or powders.

Caution! Electric storage batteries give off highly inflammable hydrogen gas when charging and continue to do so for some time after receiving a steady charge.

Caution! Do not under any circumstances allow an electric spark or an open flame near the battery. Do not lay tools across battery terminals as this may result in a spark or short circuit which may cause an explosion. Be careful to avoid spilling any electrolyte on hands or clothing.

For dependable battery service, see your International Harvester dealer.

PNEUMATIC TIRES

REAR TIRES

6-12 rear tires are standard equipment on the International Cub Cadet 73, 106, and 107 Tractors.

23 x 8.50-12 high floatation tires are standard equipment on the International Cub Cadet 126, 127 and 147 Tractors. They are also available as extra equipment when ordered for the International Cub Cadet 73, 106, and 107 Tractors.

The high floatation tires provide maximum mobility in sand, snow, and soft soil conditions. The reduced ground pressure and low inflation provides maximum protection for turf, soil, and crops.

CARE OF TIRES

Avoid stumps, stones, deep ruts, curbs, and other hazards. Cuts in tires should be repaired immediately as neglect decreases the tire life.

Keep tires free from oil and grease as both destroy rubber.

After using the tractor for spraying use water to remove any chemicals that may be on the tires.

INFLATION

Keep the pneumatic tires properly inflated. Overinflation will cause operator discomfort. Underinflation will cause short tire life.

Always see that the tire valve caps are in place and tightened securely to prevent the loss of air and protect the valve core and stem.

OPERATING PRESSURE FOR TIRES

Inflate the front and rear tires for normal or heavy load operations as shown in the following table.

Tire Size	Normal Load Operations	Heavy Load Operations
Front Tires	Pounds per square inch	
4.80/4.00-8	8	10
16 x 6.50-8	6	6
Rear Tires		
6-12	6	8
23 x 8.50-12	6	6

MOUNTING TIRES ON THE RIM

After mounting a new or old tire on the rim, inflate it to 20 pounds pressure to seat the tire bead on the rim flange and to prevent the tire from creeping and shearing off the valve. Then deflate the tire to the correct operating pressure.

REAR WHEEL WEIGHTS

Rear wheel weights increase traction and reduce wheel slippage. The weights weigh approximately 26 pounds each. They are attached to each rear wheel with two bolts, lock washers, and hex. nuts.

If additional weight is desired, a second set of weights can be attached to each first weight by using two longer bolts.

TIRE CHAINS

Tire chains will provide additional traction for wet ground conditions, when plowing snow, or pulling heavy loads. Rear wheel weights are recommended when using chains.

FRONT WHEELS

FRONT WHEEL TOE-IN

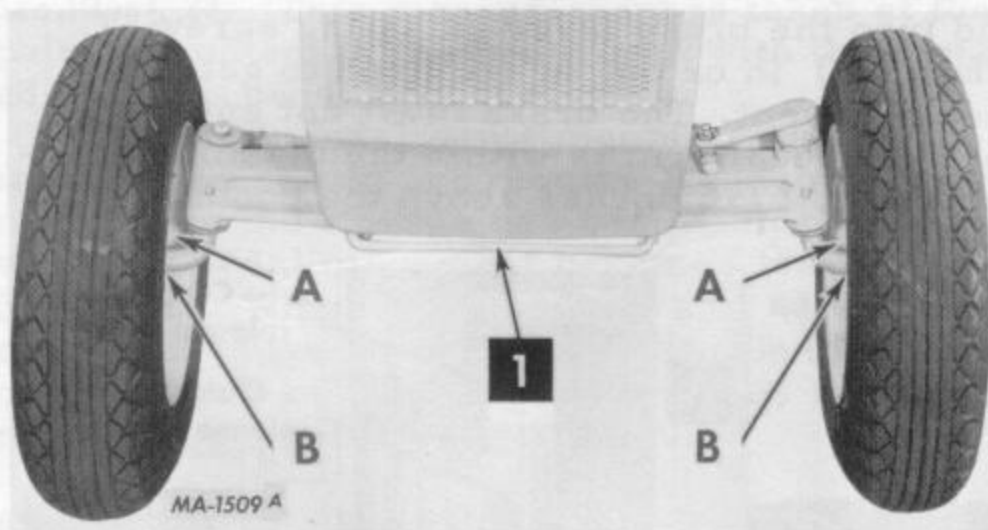

1. Front quick attaching latch.

Illust. 21
Front wheel adjustments.

The front wheel toe-in dimension is 1/32-inch to 1/8-inch toe-in (1/32-inch to 1/8-inch closer in front than in the rear). Measure the distance between two points "A" and two points "B" Illust. 21. Points "A" and "B" must be on the inside of the wheels at the outer edges and at the same height from the ground as the front wheel hubs.

To adjust the toe-in, (Illust. 21A) loosen the lock nuts "C" at both ball joints and turn the tie rod ball joint in or out as required.

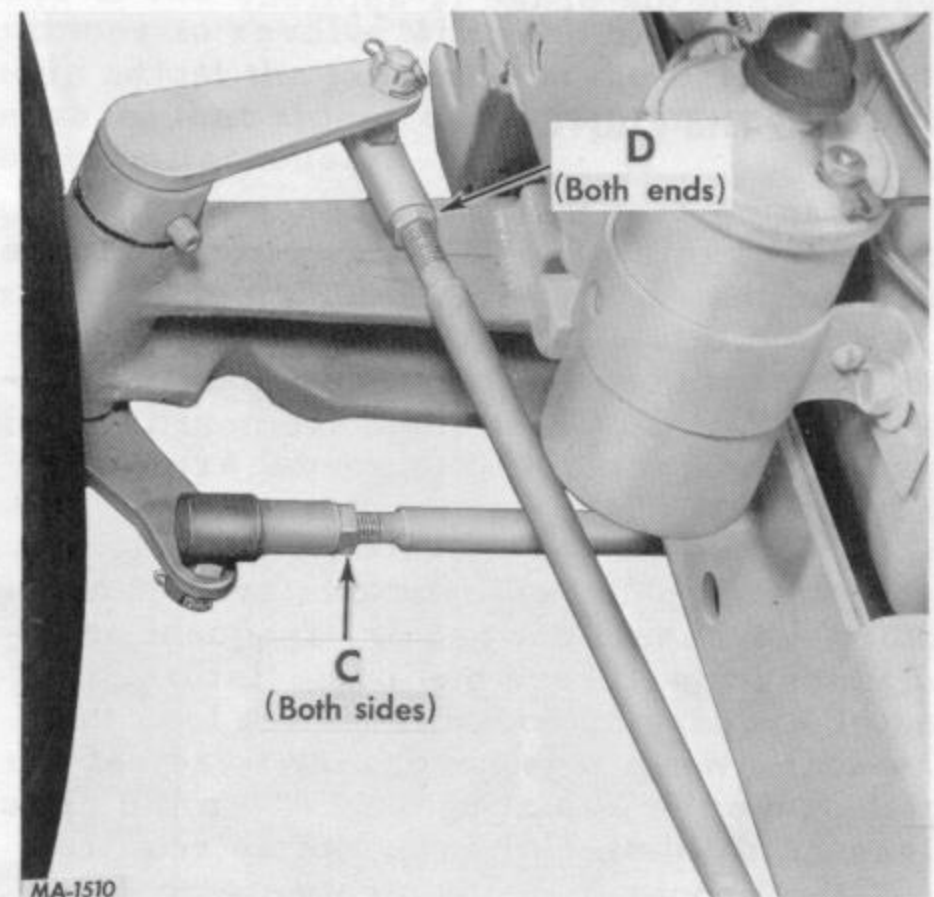

Illust. 21A
Tie rod and drag link ball joints.

TURNING RADIUS

The front wheels should have an equal angle for left and right turns. If adjustment is necessary loosen lock nuts "D" (Illust. 21A) and turn the drag link ball joint clockwise or counterclockwise as required.

CLUTCH—BRAKE

International Cub Cadet 73 Tractor

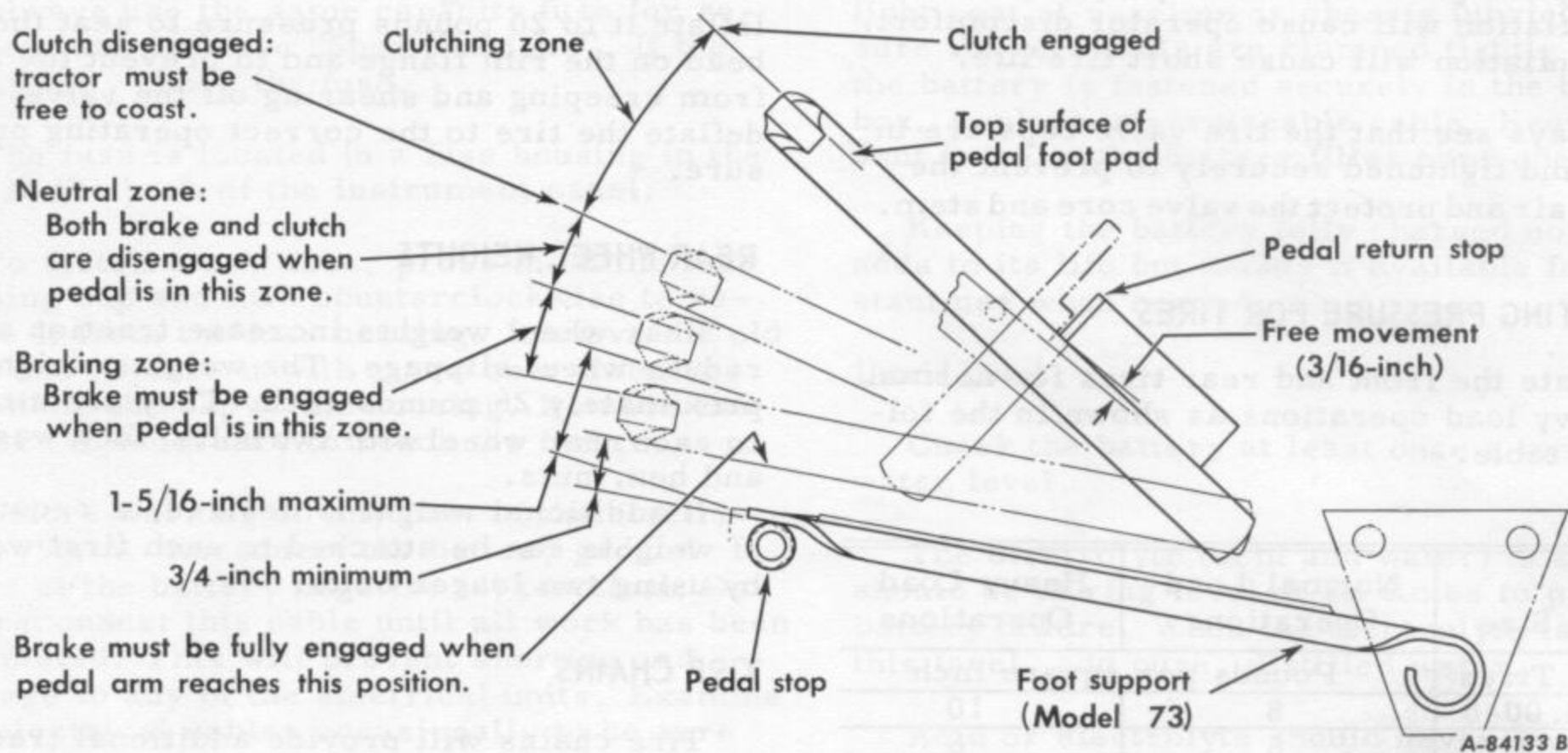

Illust. 22
Clutch and brake adjustments.

As the clutch and brake are both operated by the same pedal, care must be taken to maintain a neutral zone so the clutch is disengaged when the brake is applied.

ADJUSTING THE CLUTCH

It is important that a clearance of .050-inch be maintained between the clutch release lever and the clutch release bearing. In order to maintain this clearance, the pedal should have a free movement of approximately 3/16-inch. See Illust. 22. This measurement is taken at the point of contact of the pedal arm with the front edge of the pedal return stop.

The clutch pedal adjustments are set at the factory and should not require frequent attention unless the linkage has been disturbed or when the pedal movement becomes less than 3/16-inch. When it is necessary to adjust the clutch, turn the adjusting nut "A" on the clutch release rod (Illust. 22A) in or out as required to get the proper measurements.

ADJUSTING THE BRAKE

The brake should engage when the pedal arm is pressed down to within a maximum of 1-5/16-inches and a minimum of 3/4-inch distance above the top of the left foot support, which serves as the pedal stop. See Illust. 22.

It may be possible to push the pedal all the way down to the pedal stop, but this is of no

concern as long as the brake is engaged when the pedal arm is at least 3/4-inch above the pedal stop.

To adjust the brake, loosen the jam nut "B" and turn the brake lever adjusting screw "C" (Illust. 22A) in or out as required to get this measurement. The brake must not engage before the pedal arm is within the maximum distance of 1-5/16-inches above the pedal stop.

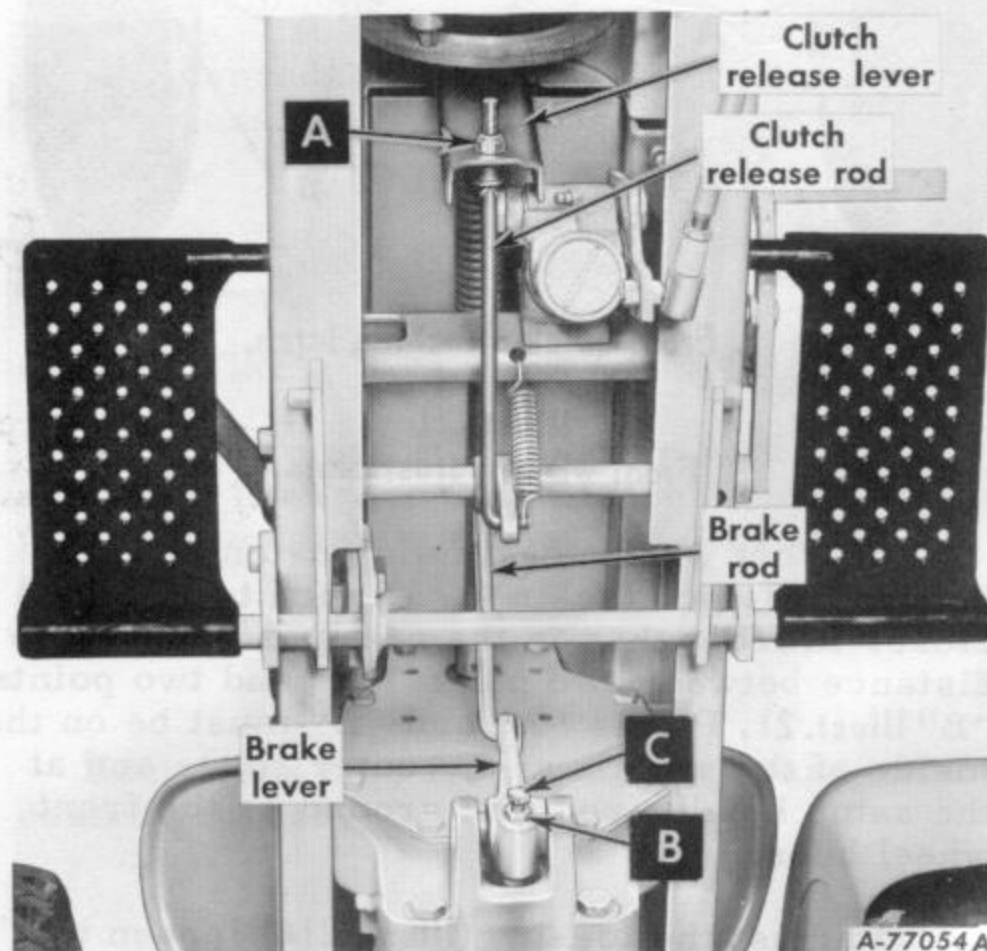

Illust. 22A
Clutch-brake adjustments.

CLUTCH — BRAKE

International Cub Cadet 106 and 126 Tractors

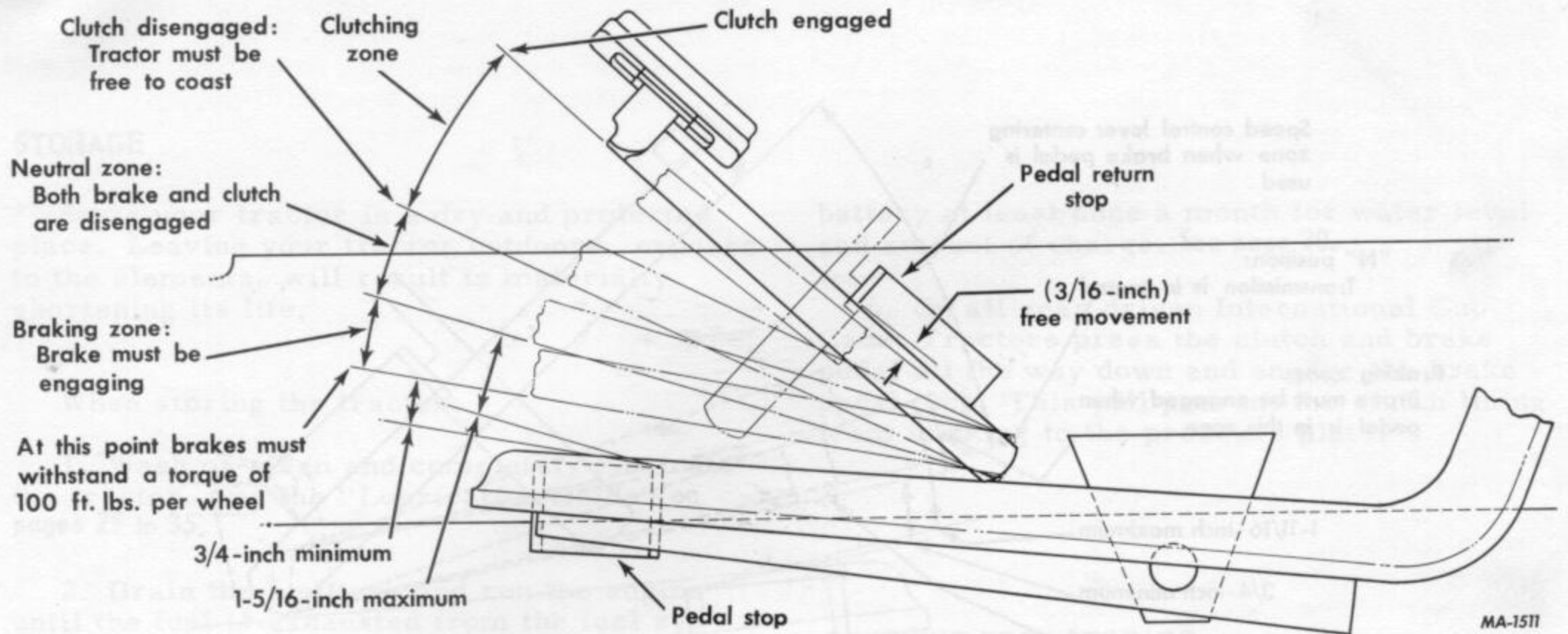

Illust. 23

ADJUSTING THE CLUTCH

It is important that a clearance of .050-inch be maintained between the clutch release lever and the clutch release bearing. In order to maintain this clearance, the pedal should have a free movement of approximately 3/16-inch. See Illust. 23. This measurement is taken at the point of contact of the pedal arm with the front edge of the pedal return stop.

The clutch pedal adjustments are set at the factory and should not require frequent attention unless the linkage has been disturbed or when the pedal movement becomes less than 3/16-inch. When it is necessary to adjust the clutch, turn the adjusting nut (No. 3 in Illust. 23A) on the clutch release rod in or out as required to get the proper measurements.

ADJUSTING THE BRAKES

The disc brakes should engage when the pedal is pressed down to within a maximum of 1-5/16-inches and a minimum of 3/4-inch above the pedal stop.

It may be possible to push the pedal all the way down to the pedal stop, but this is of no concern as long as the brake is engaged when the pedal arm is at least 3/4-inch above the pedal stop.

To adjust the brakes block the front wheels securely and raise the tractor so the rear wheels are off the ground and turn freely. Then adjust the jam nuts on the ends of the brake rods (No. 4 in Illust. 23A)

Note: The brakes must not engage before the pedal is within the maximum distance of 1-5/16-inches. See Illust. 23.

Note: It is very important to have the brakes equalized. To check the equalization of the brakes start the engine and shift the gears to third speed. After the wheels are turning apply the brakes. Both wheels should stop at the same time. If one wheel stops and the other wheel continues to revolve when the brakes are applied, adjust the jam nuts on the brake rod of the wheel that stops, enough so that both wheels stop simultaneously.

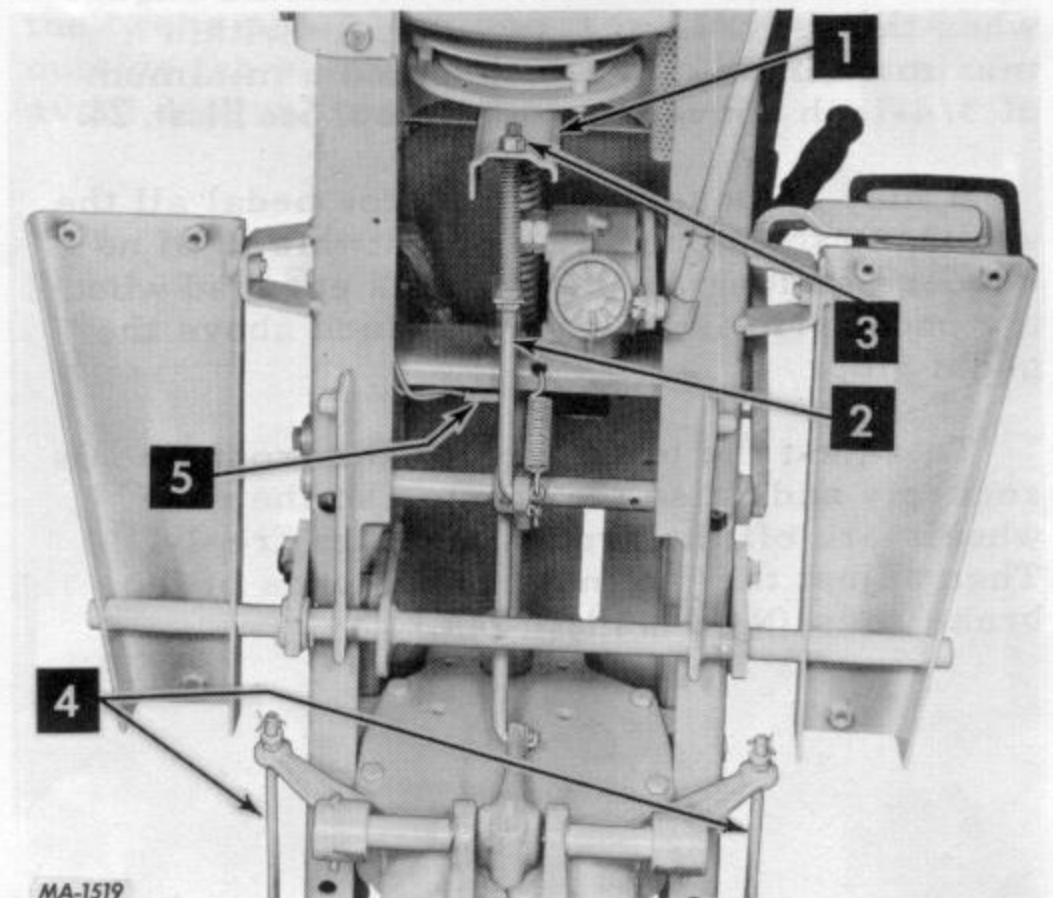

1. Clutch release lever.
2. Clutch release rod.
3. Adjusting nut.
4. Brake rods.
5. Safety starting switch.

Illust. 23A

BRAKES

(International Cub Cadet 107, 127, and 147 Tractors)

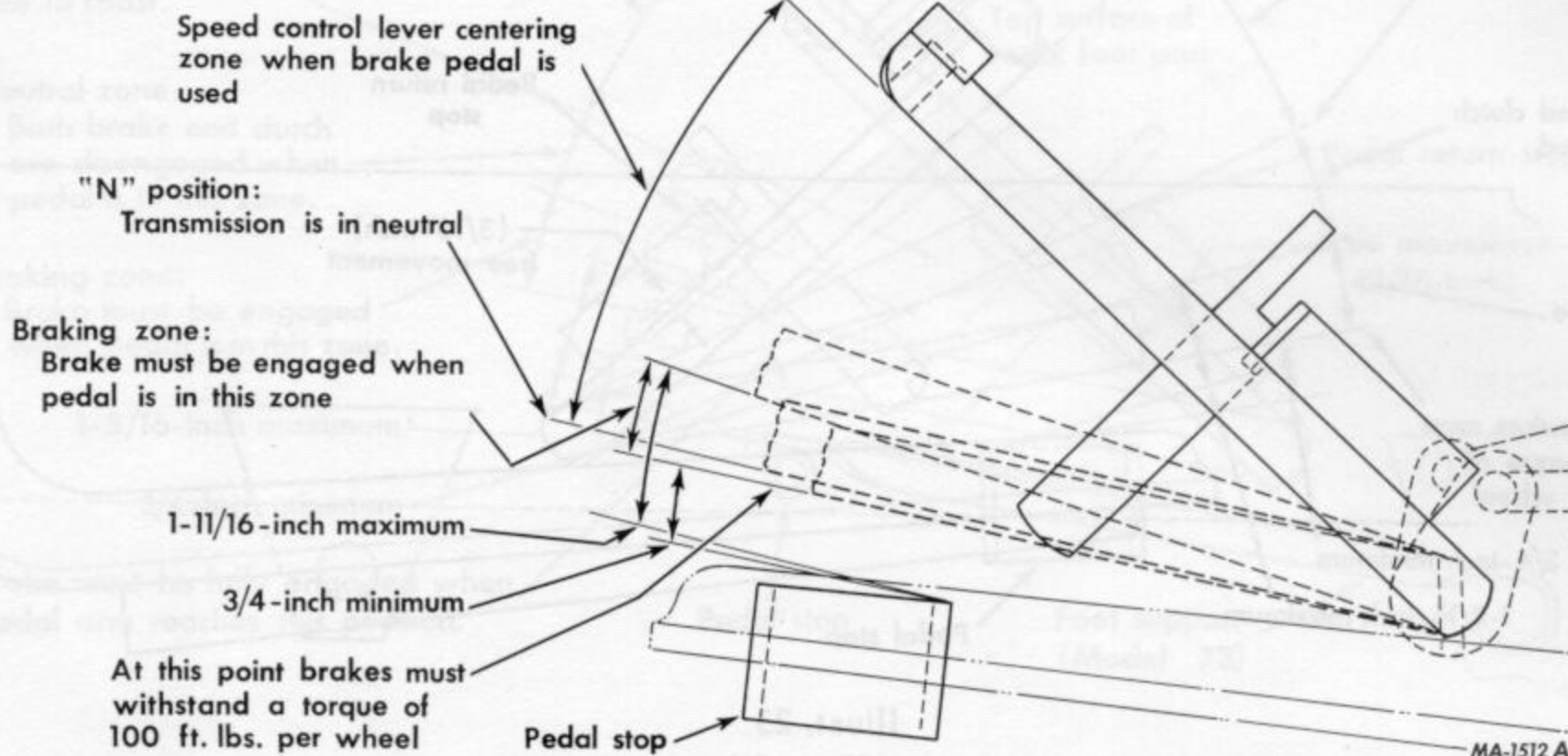

Illust. 24
Brake adjustments.

ADJUSTING THE BRAKES

The mechanical disc brakes should engage when the pedal is pressed down to within a maximum of 1-11/16-inches and a minimum of 3/4-inch above the pedal stop. See Illust. 24.

It may be possible to push the pedal all the way down to the pedal stop, but this is of no concern as long as the brake is engaged when the pedal arm is at least 3/4-inch above the pedal stop.

To adjust the brakes block the front wheels securely and raise the tractor so the rear wheels are off the ground and turn freely. Then adjust the jam nuts on the ends of the brake rods (No. 4 in Illust. 24A.)

Note: The brakes must not engage before the pedal is within the maximum distance of 1-11/16-inches. See Illust. 24.

Note: It is very important to have the brakes equalized. To check the equalization of the brakes start the engine, move the speed control lever to the forward position, and apply the brakes. Both wheels should stop at the same time. If one wheel stops and the other wheel continues to revolve when the brakes are applied, adjust the jam nuts on the brake rod of the wheel that stops, enough so that both wheels stop simultaneously.

STORING THE TRACTOR

STORAGE

Store your tractor in a dry and protected place. Leaving your tractor outdoors, exposed to the elements, will result in materially shortening its life.

When storing the tractor:

1. Wash or clean and completely lubricate the tractor. See the "Lubrication Guide" on pages 29 to 35.

2. Drain the fuel tank and run the engine until the fuel is exhausted from the fuel system. Clean the fuel strainer screen and glass bowl. See page 9.

Note: Gum will eventually form in the fuel tank, line, and carburetor if the unit is not drained. Gum can be dissolved with acetone or a 50-50 mixture of alcohol and benzol.

3. After the engine has cooled, remove the spark plug and pour one tablespoonful of Hy-Tran® into the cylinder. Crank the engine slowly turning the generator belt by hand to distribute the oil over the cylinder walls. Then replace the spark plug.

4. Clean the exterior of the engine.

5. Remove the battery and place it in a cool, dry place above freezing (+32°F.). Check the

battery at least once a month for water level and amount of charge. See page 20.

6. On all gear driven International Cub Cadet Tractors press the clutch and brake pedal all the way down and engage the brake pedal lock. This will prevent the clutch lining from sticking to the pressure plate.

REMOVING FROM STORAGE

1. Fill the fuel tank.

2. Install a fully charged battery and be sure the proper connections are made.

3. Start the engine and let it run slowly. Do not accelerate the engine rapidly, or operate it at high speed immediately after starting.

Caution! Keep the doors wide open or release the brake pedal lock and move the machine outside the storage room immediately, to avoid danger from exhaust gas.

4. Inflate the tires to the correct operating pressures. See "Pneumatic Tires" on page 21.

EXTRA EQUIPMENT AND ACCESSORIES

The tractor is used for so many different types of work, and because it is called on to operate under so many different conditions, a variety of equipment is available to adapt it to the requirements of the user.

When you purchased your tractor, you probably had it completely equipped for your

particular needs at the time. However, later you may wish to obtain some of the equipment or accessories shown below. These items and other allied equipment can be purchased from, and installed by, your International Harvester dealer.

Type of Equipment	Models used on					
	73	106	107	126	127	147
Cigarette Lighter	x	x	x	x	x	x
Charge Indicator	x	-	-	-	-	-
Creeper Drive	x	x	-	x	-	-
Detachable Seat Pad	x	-	-	-	-	-
Dual Rear Wheels	x	x	x	x	x	x
Electric Lift	x	x	x	x	x	-
Electric Lighting	x	x	x	x	x	-
Implement Handle Helper Spring	x	x	x	x	x	-
Rear Power Take-Off	x	x	x	x	x	x
Rear Wheel Fender	x	-	-	-	-	-
Rear Wheel Weights	x	x	x	x	x	x
Three-Point Hitch	x	x	x	x	x	x
Tire Chains	x	x	x	x	x	x
Tractor Cover	x	x	x	x	x	x
Utility Box	x	x	x	x	x	x

TROUBLE SHOOTING

Possible Cause

Possible Remedy

HARD TO START

- No gasoline in fuel tank or carburetor Fill the tank with gasoline; open the fuel shut-off valve. Check the fuel line, fuel strainer and carburetor.
- Fuel strainer or fuel line clogged Clean the fuel strainer, check the fuel line and carburetor.
- Water in gasoline Drain the fuel tank and carburetor. Use new fuel and dry the spark plug.
- Choked improperly. Flooded engine Follow the starting instructions.
- Defective ignition or loose wiring Check the wiring, spark plug, or breaker
- Defective battery Check and service; **See page 20**, or replace.
- Spark plug dirty or improper gap Clean, adjust the gap to .025 inch, or replace the plug.

ENGINE OPERATES IRREGULARLY OR KNOCKS

- Engine incorrectly timed *
- Spark plug dirty; wrong gap or wrong type Clean, reset the gap to .025 inch, or replace.
- Poor or weak spark Check the breaker points and breaker point opening, spark plug, and wiring. *
- Carburetor setting incorrect Adjust; see "Carburetor" on pages 9 and 10.
- Poor grade fuel or water in fuel Drain and use a good grade of clean fuel.
- Engine overheating See "Engine Cooling" **See page 17**.
- Engine valves at fault *
- Engine smokes Adjust the carburetor. Check for worn piston and rings. *
- Other engine problems *

*See your International Harvester dealer.

Possible Cause

Possible Remedy

LACK OF POWER

Air cleaner clogged	Clean or replace the air cleaner element. See page 17.
Engine overheated	Reduce the load.
Engine overloaded	Run the engine until it warms up before putting it under load. See "Engine Overheats" below.*
Poor fuel or too lean a mixture.	See "Carburetor" on pages 9 and 10.
Fuel line or strainer obstructed	Clean; see page 9.
Fuel tank air vent clogged	Open the vent in the cap.
Air leakage between carburetor and engine.	Clean the air cleaner as instructed on page 17. Tighten the carburetor and manifold mounting nuts.
Incorrect timing or faulty ignition.	See "Spark Plug" on page 17.
Clutch slipping (Models 73, 106 and 126)	Adjust the free travel of the pedal; see pages 22 and 23.
Brake drags	Adjust the brake; see pages 22,23, or 24.

ENGINE OVERHEATS

Insufficient cool air, dirty air intake screen, shroud, or cooling fins	Keep the air intake area and cooling fins clean; See "Engine Cooling and Air Cleaner" on page 17.
---	---

CREEPING

Speed control out of adjustment (Models 107, 127, and 147)	Refer to Service Manual.*
--	---------------------------

*See your International Harvester dealer.

LUBRICATION

ENGINE OIL

The tractor is shipped from the factory with engine oil in the crankcase. If the engine is to be operated at temperatures between +75 degrees F and 0 degrees F, this oil can be used for the first five hours of operation. If the temperatures are not within this range, drain the oil from the crankcase and replace it with new oil as specified in the "Lubrication Table". The engine oil must be drained and replaced with new oil every 30 hours of engine operation thereafter.

Oils designated "For Service MS" are recommended for this engine.

To Aid starting, the selection of crankcase lubricating oils should be based on the lowest anticipated temperature until the next drain period.

Check the oil levels of the engine crankcase and transmission to see that they are filled to the correct levels. **Note:** Check the oil level only while the engine is stopped.

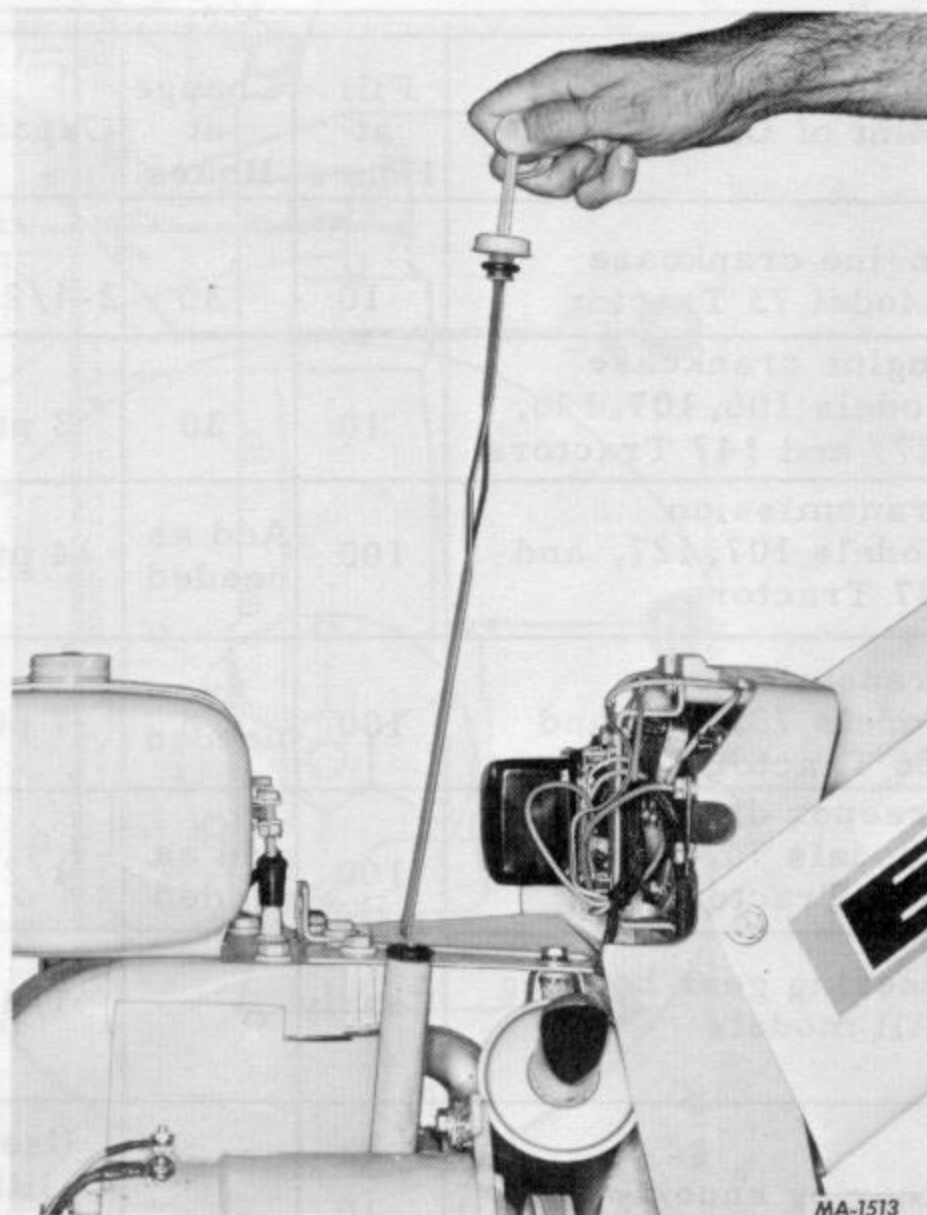

Illust. 27 - Oil level gauge.

LUBRICATION

The crankcase oil filler cap has the oil level gauge attached to it. See **Illust. 27**. Always keep the oil level between the "FULL" and the "LOW" marks on the gauge. When checking the oil level, the gauge must be withdrawn and wiped clean, then inserted all the way and withdrawn for a true reading.

Lubricate the entire tractor, using only high-quality lubricating oils and greases as specified in the "Lubrication Table". For your own protection, select only oils and greases of recognized manufacture.

Keep your supply of lubricating oil absolutely clean and free from dust. Always use clean containers. Keep the lubricator clean and wipe dirt from the lubrication fittings before applying the lubricator.

TRANSMISSION OIL FILTER

(International Cub Cadet 107, 127, and 147 Tractors)

Remove the throwaway can-type filter and replace with a new filter after the first 10 hours and after 50 hours of operation, and every 100 hours of operation thereafter.

Note: Clean the outside area before removing the filter to keep dirt from getting into the transmission case. If a mower is mounted on the tractor, the mower must be lowered to facilitate the removal of the filter.

To remove the filter, turn the filter counterclockwise using an automotive type filter wrench or an open end wrench.

Before installing the new filter, apply a coating of oil on the filter gasket. Thread the filter on by hand until tight enough to seat the gasket.

Loosen the filter. Then turn it until the gasket contacts the base. Tighten the filter an additional one half turn. Check for leaks and check oil level of transmission case.

LUBRICATION TABLE

Point of Lubrication	Fill at Hours	Change at Hours	Capacity	Anticipated Air Temperature		
				Above +32° F.	+32° F. to 0° F.	Below 0° F.
Engine crankcase Model 73 Tractor	10	30	2-1/2 pt.	SAE-30 engine oil	SAE-10W engine oil	SAE-5W or SAE-5W-20 engine oil
Engine crankcase Models 106, 107, 126, 127, and 147 Tractors	10	30	3 pt.			
Transmission Models 107, 127, and 147 Tractors	100	Add as needed	14 pt.	IH Hy-Tran® Fluid		
Transmission Models 73, 106, and 126 Tractors	100	As needed	7 pt.	IH Hy-Tran® Fluid		
Creeper drive housing Models 73, 106, and 126 Tractors	100	Add as needed	1/2 pt.	IH Hy-Tran® Fluid		
Steering gear housing All models	Yearly	-	1/4 lb.	Two strokes of the lubricator using IH-251H EP grease or equivalent #2 multi-purpose lithium grease.		
Steering knuckles All models	10	-	Use IH-251H EP grease or equivalent #2 multi-purpose lithium grease and apply two or three strokes of the lubricator or sufficient grease to flush out old grease and dirt.			

LUBRICATION GUIDE

International Cub Cadet 73 Tractor

The symbols around the reference numbers indicate the intervals of lubrication.

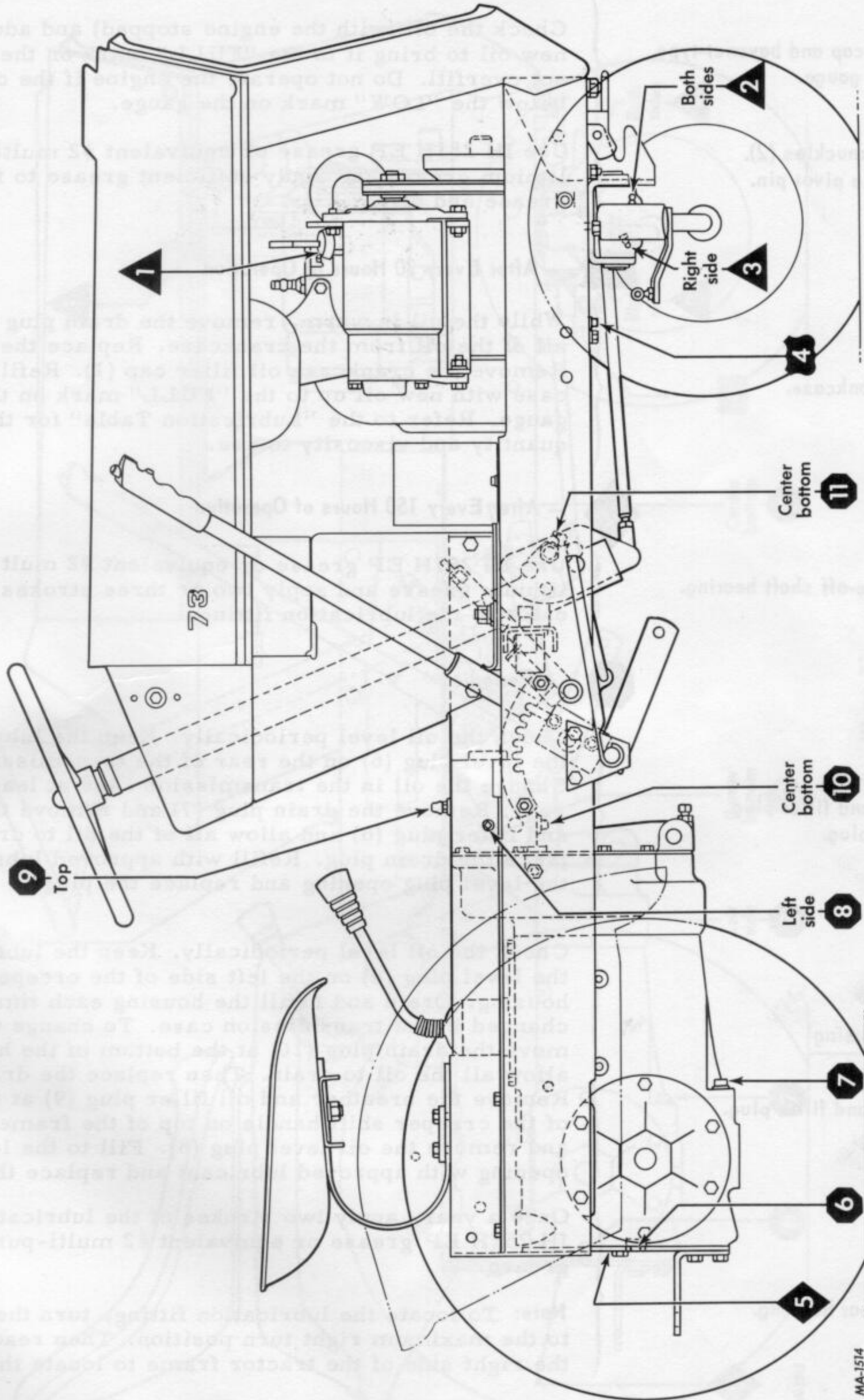

Illust. 29
Lubrication view

LUBRICATION GUIDE

International Cub Cadet 73 Tractor

▲ - After Every 10 Hours of Operation

1 - Oil filler cap and bayonet-type oil level gauge.

Check the oil (with the engine stopped) and add sufficient new oil to bring it to the "FULL" mark on the gauge. Do not overfill. Do not operate the engine if the oil level is below the "LOW" mark on the gauge.

2 - Steering knuckles (2).
3 - Front axle pivot pin.

Use IH 251H EP grease or equivalent #2 multi-purpose lithium grease and apply sufficient grease to flush out old grease and dirt.

■ - After Every 30 Hours of Operation

4 - Engine crankcase.

While the oil is warm, remove the drain plug (4) and drain all of the oil from the crankcase. Replace the drain plug. Remove the crankcase oil filler cap (1). Refill the crankcase with new oil up to the "FULL" mark on the oil level gauge. Refer to the "Lubrication Table" for the proper quantity and viscosity to use.

◆ - After Every 150 Hours of Operation

5 - Power take-off shaft bearing.

Use IH 251H EP grease or equivalent #2 multi-purpose lithium grease and apply two or three strokes of the lubricator to the lubrication fittings.

● - Periodic

Transmission

6 - Oil level and filler plug.
7 - Oil drain plug.

Check the oil level periodically. Keep the lubricant up to the level plug (6) on the rear of the transmission case. Change the oil in the transmission case at least once a year. Remove the drain plug (7) and remove the oil level and filler plug (6) and allow all of the oil to drain out. Replace the drain plug. Refill with approved lubricant up to the level plug opening and replace the plug.

Creeper drive housing

8 - Level plug.
9 - Breather and filler plug.
10 - Drain plug.

Check the oil level periodically. Keep the lubricant up to the level plug (8) on the left side of the creeper drive housing. Drain and refill the housing each time the oil is changed in the transmission case. To change the oil, remove the drain plug (10) at the bottom of the housing and allow all the oil to drain. Then replace the drain plug. Remove the breather and oil filler plug (9) at the right of the creeper shift handle on top of the frame assembly, and remove the oil level plug (8). Fill to the level plug opening with approved lubricant and replace the plugs.

11 - Steering gear housing.

Once a year, apply two strokes of the lubricator, using IH 251H EP grease or equivalent #2 multi-purpose lithium grease.

Note: To locate the lubrication fitting, turn the front wheels to the maximum right turn position. Then reach up under the right side of the tractor frame to locate the fitting.

Miscellaneous

Lubricate the clutch pedal shaft and linkage with eight or ten drops of engine oil.

LUBRICATION GUIDE

International Cub Cadet 106 and 126 Tractors

The symbols around the reference numbers indicate the intervals of lubrication.

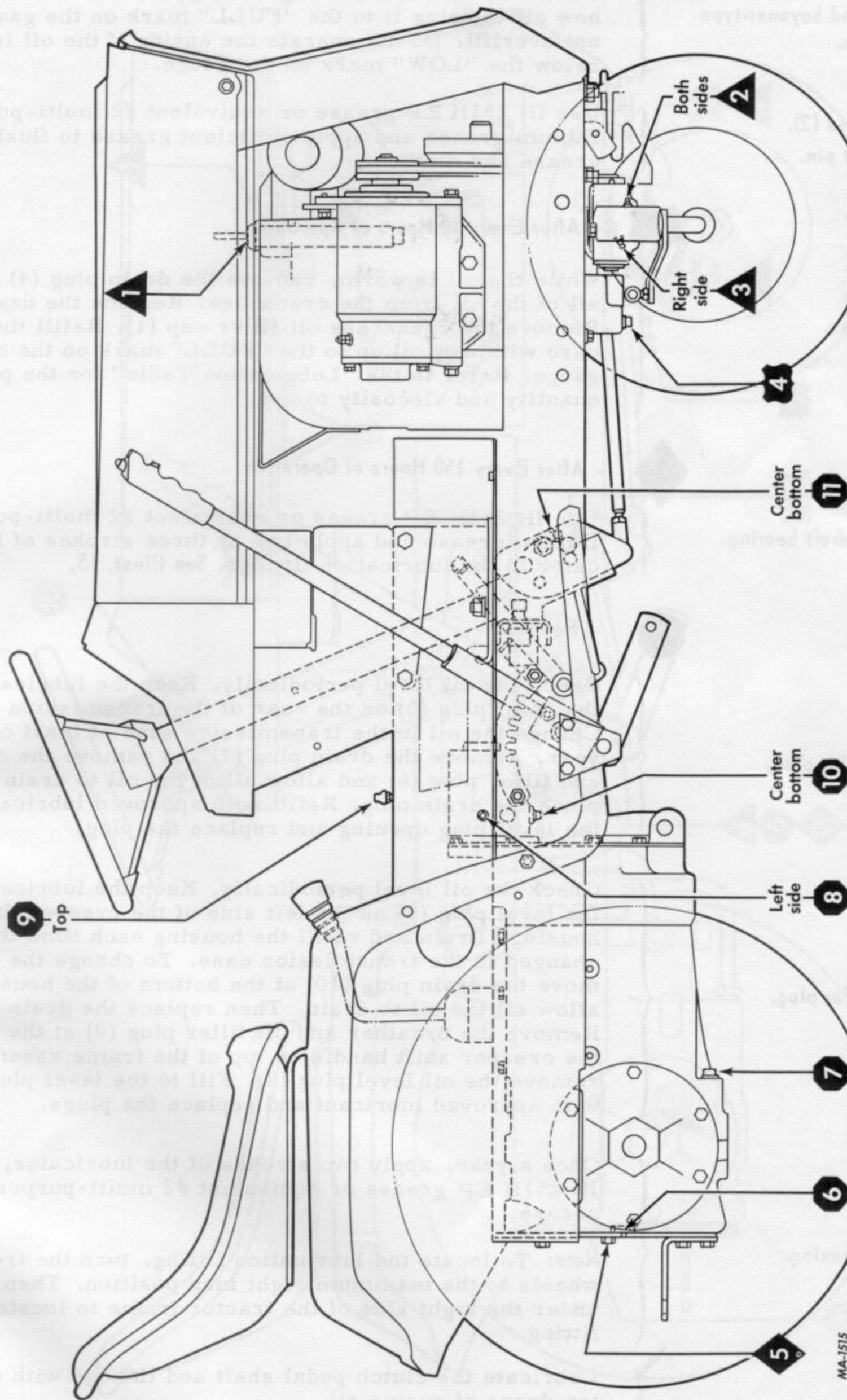

Illust. 31
Lubrication view

MA-1515

LUBRICATION GUIDE

International Cub Cadet 106 and 126 Tractors



- After Every 10 Hours of Operation

1 - Oil filler cap and bayonet-type oil level gauge.

Check the oil (with the engine stopped) and add sufficient new oil to bring it to the "FULL" mark on the gauge. Do not overfill. Do not operate the engine if the oil level is below the "LOW" mark on the gauge.

2 - Steering knuckles (2).
3 - Front axle pivot pin.

Use IH 251H EP grease or equivalent #2 multi-purpose lithium grease and apply sufficient grease to flush out old grease and dirt.



- After Every 30 Hours of Operation

4 - Engine crankcase.

While the oil is warm, remove the drain plug (4) and drain all of the oil from the crankcase. Replace the drain plug. Remove the crankcase oil filler cap (1). Refill the crankcase with new oil up to the "FULL" mark on the oil level gauge. Refer to the "Lubrication Table" for the proper quantity and viscosity to use.



- After Every 150 Hours of Operation

5 - Power take-off shaft bearing.

Use IH 251H EP grease or equivalent #2 multi-purpose lithium grease and apply two or three strokes of the lubricator to the lubrication fittings. See Illust. 15.



- Periodic

Transmission

6 - Oil level and filler plug.
7 - Oil drain plug.

Check the oil level periodically. Keep the lubricant up to the level plug (6) on the rear of the transmission case. Change the oil in the transmission case at least once a year. Remove the drain plug (7) and remove the oil level and filler plug (6) and allow all of the oil to drain out. Replace the drain plug. Refill with approved lubricant up to the level plug opening and replace the plug.

Creeper drive housing

8 - Level plug.
9 - Breather and filler plug.
10 - Drain plug.

Check the oil level periodically. Keep the lubricant up to the level plug (8) on the left side of the creeper drive housing. Drain and refill the housing each time the oil is changed in the transmission case. To change the oil, remove the drain plug (10) at the bottom of the housing and allow all the oil to drain. Then replace the drain plug. Remove the breather and oil filler plug (9) at the right of the creeper shift handle on top of the frame assembly, and remove the oil level plug (8). Fill to the level plug opening with approved lubricant and replace the plugs.

11 - Steering gear housing.

Once a year, apply two strokes of the lubricator, using IH 251H EP grease or equivalent #2 multi-purpose lithium grease.

Note: To locate the lubrication fitting, turn the front wheels to the maximum right turn position. Then reach up under the right side of the tractor frame to locate the fitting.

Miscellaneous

Lubricate the clutch pedal shaft and linkage with eight or ten drops of engine oil.

LUBRICATION GUIDE

(International Cub Cadet 107, 127, and 147 Tractors)

The symbols around the reference numbers indicate the intervals of lubrication.

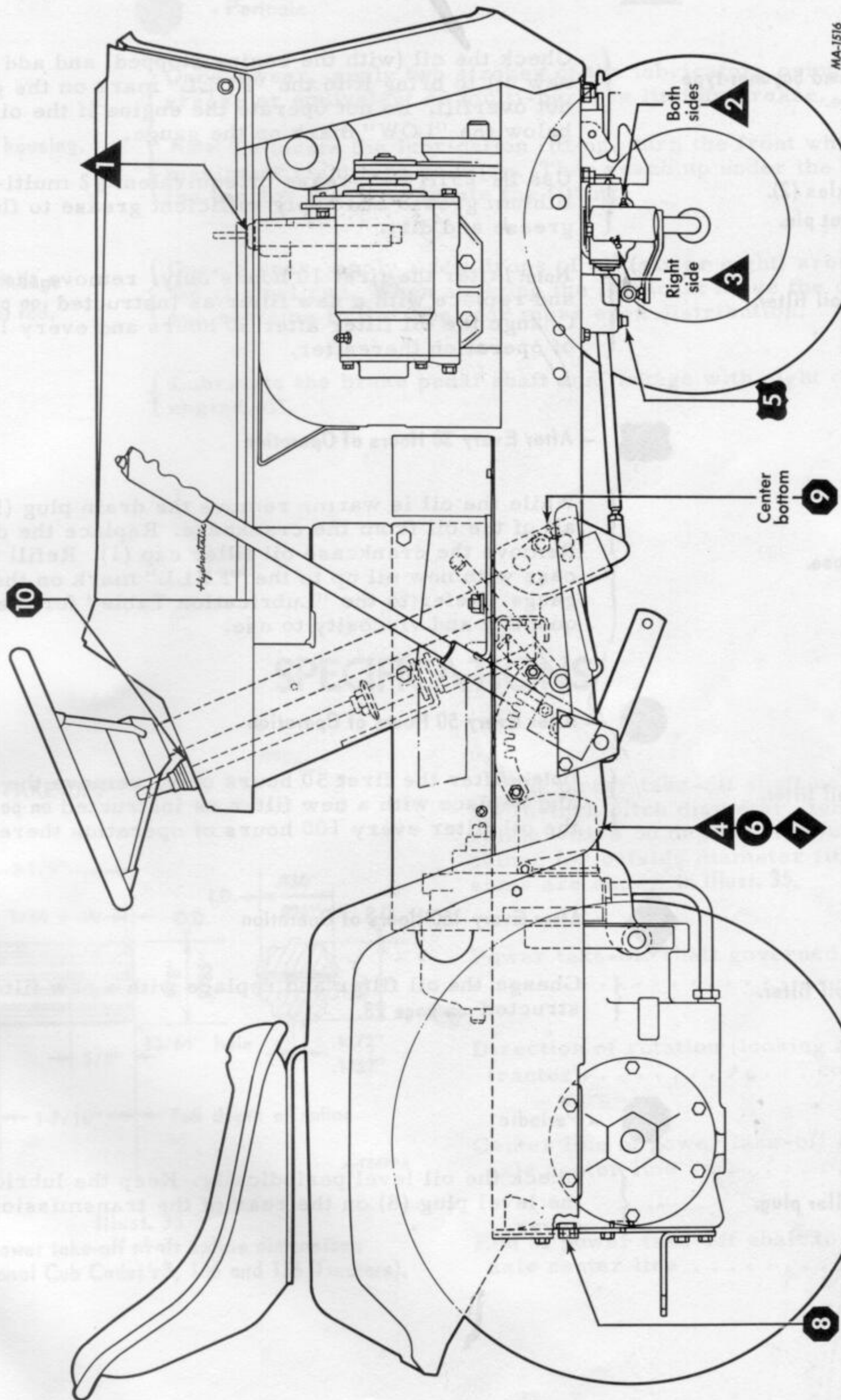

Illust. 33
Lubrication view

LUBRICATION GUIDE

(International Cub Cadet 107, 127, and 147 Tractors)



- After Every 10 Hours of Operation

1. Oil filler cap and bayonet-type oil level gauge.

Check the oil (with the engine stopped) and add sufficient new oil to bring it to the "FULL" mark on the gauge. Do not overfill. Do not operate the engine if the oil level is below the "LOW" mark on the gauge.

2. Steering knuckles (2).
3. Front axle pivot pin.

Use IH-251H EP grease or equivalent #2 multi-purpose lithium grease and apply sufficient grease to flush out old grease and dirt.

4. Transmission oil filter.

Note: After the first 10 hours only, remove the old filter and replace with a new filter as instructed on page 28. Change the oil filter after 50 hours and every 100 hours of operation thereafter.



- After Every 30 Hours of Operation

5. Engine crankcase.

While the oil is warm, remove the drain plug (5) and drain all of the oil from the crankcase. Replace the drain plug. Remove the crankcase oil filler cap (1). Refill the crankcase with new oil up to the "FULL" mark on the oil level gauge. Refer to the "Lubrication Table" for the proper quantity and viscosity to use.



- After Every 50 Hours of Operation

6. Transmission oil filter.

Note: After the first 50 hours only, remove the old filter and replace with a new filter as instructed on page 28. Change the oil filter every 100 hours of operation thereafter.



- After Every 150 Hours of Operation

7. Transmission oil filter.

Change the oil filter and replace with a new filter as instructed on page 28.



- Periodic

Transmission

8. Oil level and filler plug.

Check the oil level periodically. Keep the lubricant up to the level plug (8) on the rear of the transmission case cover.

● - Periodic

- 9. Steering gear housing. } Once a year, apply two strokes of the lubricator, using IH 251H EP grease or equivalent #2 multi-purpose lithium grease.
} **Note:** To locate the lubrication fitting, turn the front wheels to the maximum right turn position. Then reach up under the right side of the tractor frame to locate the fitting.
- Speed Control Linkage
- 10. Speed control rod. } Once a year, apply a few drops of oil (six or eight) around the base of the control rod. When applying the lubricant move the control rod from one extreme to the other for more even distribution.
- Miscellaneous } Lubricate the brake pedal shaft and linkage with eight or ten drops of engine oil.

SPECIFICATIONS

REAR POWER TAKE-OFF

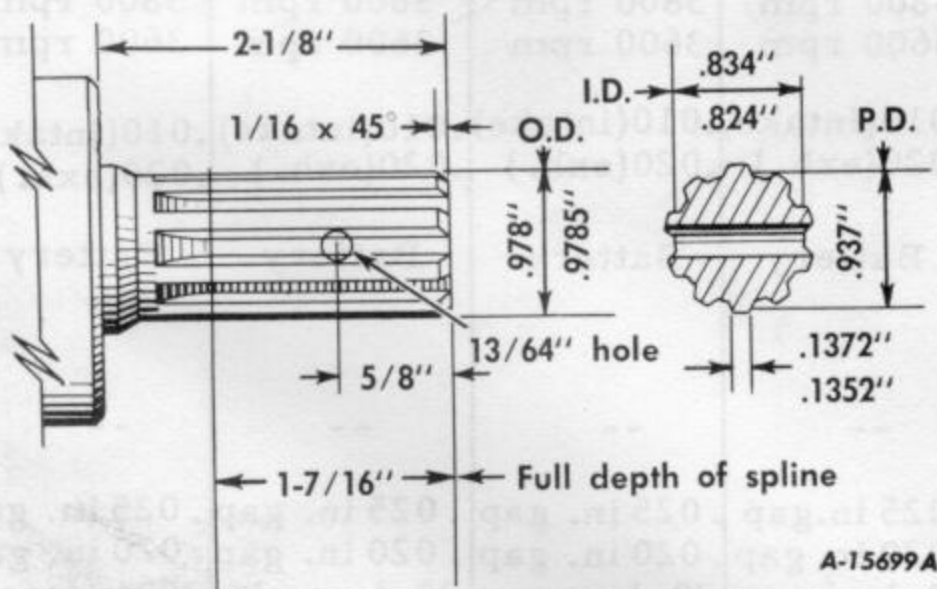

Illustr. 35
Rear Power take-off shaft spline dimensions
(International Cub Cadet 73, 106 and 126 Tractors).

The power take-off shaft connection is a 15/16-inch pitch diameter, ten-tooth involute spline with a 30 degree pressure angle, machined for outside diameter fit. The dimensions are shown in **Illustr. 35**.

Power take-off shaft governed speed
..... 515 r.p.m.

Direction of rotation (looking at rear of tractor)..... counterclockwise

Center line of power take-off shaft above rear axle center line 3-1/4-in.

End of power take-off shaft to rear of rear axle center line 7-7/16-in.

SPECIFICATIONS

	Model 73	Model 106	Model 107	Model 126	Model 127	Model 147
CAPACITIES (APPROXIMATE - U. S. MEASURE)						
Fuel tank	5 qt.	6-1/2 qt.	6-1/2 qt.	8 qt.	8 qt.	8 qt.
Crankcase	2-1/2 pt.	3 pt.	3 pt.	3 pt.	3 pt.	3 pt.
Transmission case	7 pt.	7 pt.	14 pt.	7 pt.	14 pt.	14 pt.
Steering gear housing	1/4 lb.	1/4 lb.	1/4 lb.	1/4 lb.	1/4 lb.	1/4 lb.
Creeper drive housing	1/2 pt.	1/2 pt.	--	1/2 pt.	--	--
TRANSMISSION GEARS						
Speed: 1st	2.3 mph	2.3 mph	--	2.3 mph	--	--
2nd	3.9 mph	3.9 mph	--	3.9 mph	--	--
3rd	6.9 mph	6.9 mph	--	6.9 mph	--	--
Reverse	2.5 mph	2.5 mph	--	2.5 mph	--	--
HYDROSTATIC DRIVE						
Speed: Forward	--	--	0 to 8 mph	--	0 to 8 mph	0 to 8 mph
Reverse	--	--	0 to 4 mph	--	0 to 4 mph	0 to 4 mph
ENGINE						
Make and model	Kohler K 161S	Kohler K 241 AS	Kohler K 241 AS	Kohler K 301 AS	Kohler K 301 AS	Kohler K 321 A
(electric starting)						
Cylinders	1	1	1	1	1	1
Bore	2-7/8 in.	3-1/4 in.	3-1/4 in.	3-3/8 in.	3-3/8 in.	3-1/2 in.
Stroke	2-1/2 in.	2-7/8 in.	2-7/8 in.	3-1/4 in.	3-1/4 in.	3-1/4 in.
Displacement	16.23	23.9	23.9	29.07	29.07	31.27
Engine speed (governed)						
Low speed	1000 rpm	1000 rpm	1000 rpm	1000 rpm	1000 rpm	1000 rpm
High idle speed						
(no load)	3780 rpm	3800 rpm	3800 rpm	3800 rpm	3800 rpm	3800 rpm
Full load	3600 rpm	3600 rpm	3600 rpm	3600 rpm	3600 rpm	3600 rpm
Valve clearance						
(engine cold)006(intake) .017(exh.)	.010(intake) .020(exh.)	.010(intake) .020(exh.)	.010(intake) .020(exh.)	.010(intake) .020(exh.)	.010(intake) .020(exh.)
Ignition (electric starting)	Battery	Battery	Battery	Battery	Battery	Battery
Spark plug gap (14mm plug) (Champion J-8 or equivalent)025 in. gap	--	--	--	--	--
(Champion H-10 or equivalent)	--	.025 in. gap	.025 in. gap	.025 in. gap	.025 in. gap	.025 in. gap
Breaker points020 in. gap	.020 in. gap	.020 in. gap	.020 in. gap	.020 in. gap	.020 in. gap
Timing	20 degrees before TDC	20 degrees before TDC	20 degrees before TDC	20 degrees before TDC	20 degrees before TDC	20 degrees before TDC

OPERATING INSTRUCTIONS

SPECIFICATIONS

	Model 73	Model 106	Model 107	Model 126	Model 127	Model 147
ELECTRICAL SYSTEM						
System voltage . . .	12 volt neg. ground	12 volt neg. ground	12 volt neg. ground	12 volt neg. ground	12 volt neg. ground	12 volt neg. ground
Battery	9943X	9948X	9948X	9948X	9948X	9948X
Motor generator, Delco-Remy	15 amp.	15 amp.	15 amp.	15 amp.	15 amp.	15 amp.
Voltage regulator, Delco-Remy	2 unit	2 unit	2 unit	2 unit	2 unit	2 unit
Fuse (cartridge type) . .	AGC-10 amp.	AGC-10 amp.	AGC-10 amp.	AGC-10 amp.	AGC-10 amp.	AGC-10 amp.
			<u>Lamp No.</u>	<u>IH part No.</u>		
Headlights - all glass, sealed beam units			4411	373 662 R91		
Taillight			67	142 450		

SPECIFICATIONS

FOOT BRAKE

Disc type, on transmission shaft for Cub Cadet 73 Tractor 4-1/2 in.
 Rear wheel disc type for all other models

CLUTCH

Double-plate, dry disc, spring loaded (Models 73, 106, and 126 Tractors) 4-1/2 in.

WHEELS AND TREAD

Front wheels, pneumatic tire size { Models 73, 106, 107, 126,
 and 127 Tractors †4.80/4.00-8
 Model 147 Tractor 16x6.50-8

Rear wheels, pneumatic tire size { Models 73, 106, and 107 Tractors †6-12
 Models 126, 127, and 147 Tractors 23x8.50-12

Wheelbase 43 in.
 Tread 27 in.

GENERAL

Length, over-all 64 in.
 Width, over-all { Models 73, 106, and 107 Tractors 33- 1/4 in.
 Models 126 and 127 Tractors 36 in.

Height, over-all (to top of steering wheel) 39-3/4 in.
 Ground clearance 6 in.
 Turning radius 6-3/4 ft.

† Other pneumatic tire sizes are available.

Specifications are subject to change without notice.

OPERATING INSTRUCTIONS

INTERNATIONAL[®]

ROTARY MOWERS

(38, 42, and 48-inch, 3 spindle)

(Quick-attachable mounting)



MA-1517 A

Illust. 39

To The Owner

Your new rotary mower is designed to meet today's exacting operating requirements. The ease of operation and ability to adjust to field conditions lighten your work and shorten your hours on the job.

You are urged to consult your International Harvester dealer concerning unusual field conditions or special applications. Let the experience of your dealer and the organization associated with him serve you.

Be sure to read the instructions for Adjusting and Operating in this manual. Check

each item referred to and acquaint yourself with the adjustments required to obtain efficient operation and maximum trouble-free performance. Remember, a machine which is properly lubricated and adjusted saves time, labor, and fuel.

After the operating season, thoroughly clean your mower and inspect it. Preventive maintenance pays dividends. Your dealer has original-equipment parts which assure proper fit and best performance. He is able to recondition your equipment to a like new condition.

INTRODUCTION

The 3 spindle, center mounted, 38-, 42-, and 48-inch rotary mowers, are designed for use on International® Cub Cadet® Tractors having serial number 65458 and higher.

The mower extends beyond the tractor wheels to permit cutting close to shrubbery, trees, fences, buildings, drive and walkway edges, etc.

The mower is driven by a V-belt from the engine mounted power take-off clutch. The clutch is engaged and disengaged by means of a hand lever mounted on the steering wheel standard.

A heavy-duty V-belt connects the three spindles and permits independent turning of the blades when an obstruction is struck by a blade. A spring-loaded belt tightener maintains proper belt tension.

The 48-inch mower has a spindle drive system wherein each spindle; from left to right, is driven progressively faster to aid in cutting and discharging the cut material.

The blade spindle bearings are automotive type tapered roller bearings that can be re-lubricated and are carefully enclosed and protected by seals.

The three cutting blades are designed to create a suction to lift the grass and hold it for an even cut.

Raising and lowering of the mower is done by means of the tractor lift handle or the power lift attachment.

The lift linkage provides and maintains a true parallel lift for the mower throughout the cutting height range of 1 to 4 inches.

The lift linkage with mounting brackets can be quickly detached by removing the quick-attachable cotter pins and releasing the tractor quick hitch.

The tapered discharge chute terminates at a large, protected opening for efficient air and material flow across the front of the mower to minimize clogging.

OPERATING YOUR MOWER

1. Mower must be supported on the tractor. See page 42.
2. Level the mower. See page 42.
3. Engine Speed: Operate the engine at full throttle.
4. Ground Speed: Choose a ground speed that will satisfactorily handle the amount of material to be cut.

ADJUSTING AND OPERATING

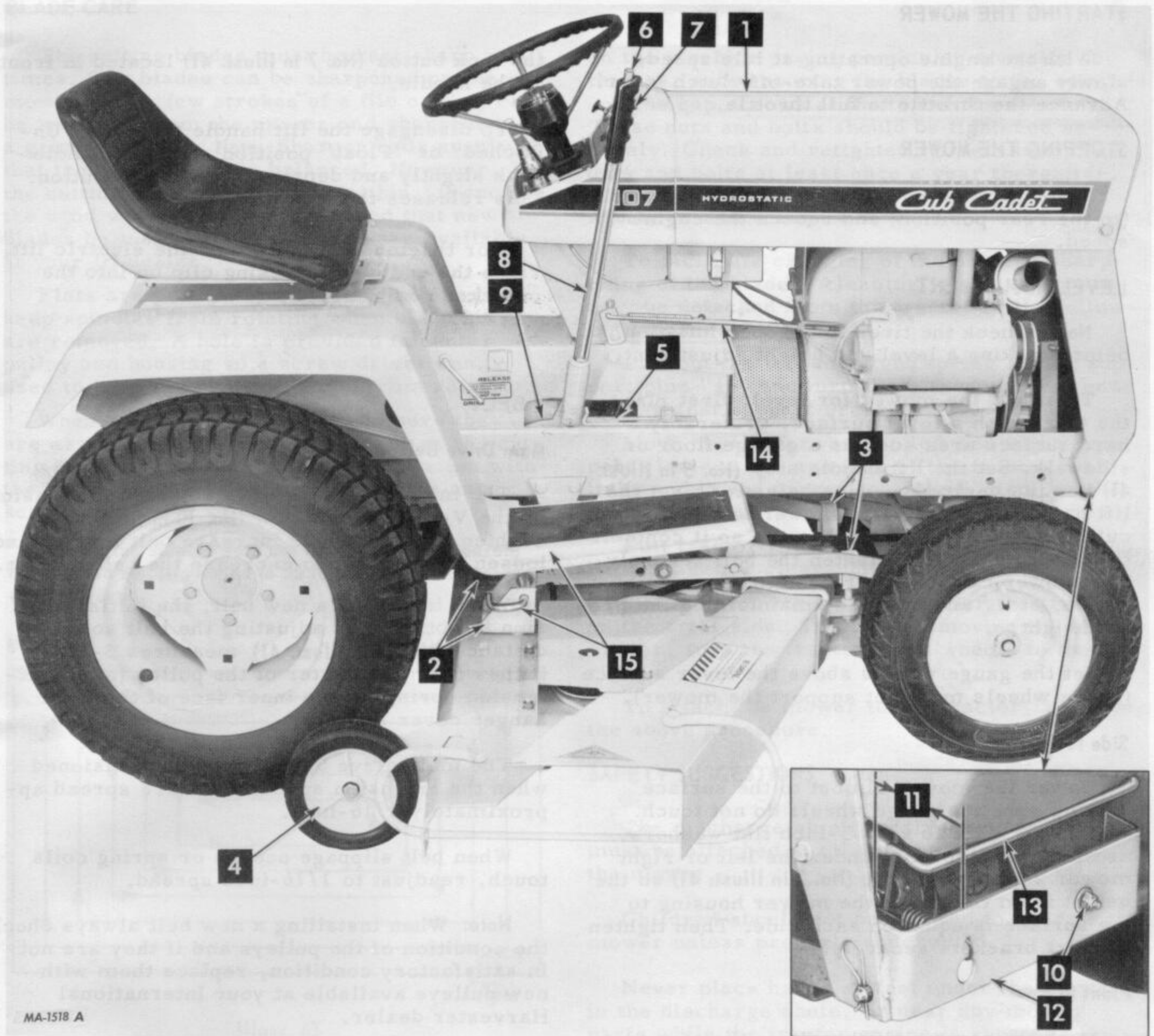

1. Power take-off clutch lever (not seen)
2. Mower support brackets
3. Mower support clevises
4. Gauge wheels
5. Lift handle stop
6. Release button
7. Lock button
8. Lift handle

9. Lift handle quadrant
10. V-belt tension bolt
11. Extension spring
12. Front hanger cover
13. Quick hitch
14. Power take-off clutch rod
15. Support pins (spring loaded)

Illust. 41

LUBRICATION

After every 16 hours of operation, lubricate the three spindle bearings (one fitting in each spindle), using IH 251H EP grease or equivalent No. 2 multi-purpose lithium grease.

Caution! Never look into the discharge opening while the blades are in motion.

Caution! Stop the tractor engine before attempting to clean or work on the mower.

ADJUSTING AND OPERATING

STARTING THE MOWER

With the engine operating at idle speed, slowly engage the power take-off clutch lever. Advance the throttle to full throttle.

STOPPING THE MOWER

Disengage the power take-off clutch lever (to the rear position) and reduce the engine speed.

LEVEL ADJUSTMENT

Note: Check the tires for proper inflation before making a level and height adjustment.

To adjust the mower for level, first place the tractor on a level surface, preferably a hard surface area such as a garage floor or sidewalk. Set the lift handle stop (No. 5 in Illust. 41) for the desired mowing height. To set the lift handle stop raise the mower to the desired cutting height and adjust the stop so it contacts the lift handle. Then tighten the bolt securely. The mower can then be raised to cross an obstacle, etc., and lowered, maintaining the pre-set height.

Set the gauge wheels above the level surface (gauge wheels must not support the mower).

Side to Side

Lower the mower almost to the surface making sure the gauge wheels do not touch. Add 13/32 x 13/16 x .065-inch flat washers, as many as required, under the left or right mower support bracket (No. 2 in Illust. 41) so the height from the top of the mower housing to the surface is equal on each side. Then tighten support brackets securely.

Front to Rear

Push the tractor lift handle to the stop to lower the mower to the mowing height. Rotate the center and one outer blade so they are parallel and pointing straight to the front and rear. Then adjust the left and right support clevises (No. 3 in Illust. 41) so the front edge of the center blade is level with the back edge of the outer blade. If the mower is to be used for close cutting of fine lawns, the front tip of the center blade should be set at the same height as the rear tip of the outer blades.

Note: If mower is not level, it will adversely affect the performance.

HEIGHT OF CUT

Set the lift handle stop for the desired height of cut. To lock the handle in the float position depress the release button (No. 6) and press in

the lock button (No. 7 in Illust. 41) located in front of the handle.

To disengage the lift handle from the "Unlatched" or "Float" position, pull the handle back slightly and depress the release button. This releases the lock button.

For tractors equipped with the electric lift, raise the end clevis locking clip up into the unlocked position. See page 17.

V-BELT

Main Drive Belt

The main drive V-belt is adjusted for tension by the V-belt tension bolt (No. 10 in Illust. 41). Tighten the lock nut to increase belt tension and loosen the lock nut to decrease the belt tension.

When installing a new belt, the initial tension is obtained by adjusting the belt so the distance (No. 11 in Illust. 41) measures 3-1/2-inches from the center of the pulley (at the extension spring) to the inner face of the front hanger cover (No. 12).

The main drive belt is properly tensioned when the extension spring coils are spread approximately 1/16-inch.

When belt slippage occurs or spring coils touch, readjust to 1/16-inch spread.

Note: When installing a new belt always check the condition of the pulleys and if they are not in satisfactory condition, replace them with new pulleys available at your International Harvester dealer.

To install or remove the belt, pull the lift handle to the rearward position and disconnect the power take-off clutch lever rod, or loosen clutch lever bolt. This will provide sufficient clearance between the wear and thrust buttons on the clutch. See Illusts. 16, 16A, and 16B.

Spindle Drive Belt

The spindle drive belt tension is maintained by a spring-loaded belt tightener and requires no adjustment.

CLEANING

Clean the underside of the mower at the end of the mowing season and when the build-up of cut material on the underside is noticed.

BLADE CARE

The cutting blades must be kept sharp at all times. The blades can be sharpened on the mower with a few strokes of a file or they can be removed from the mower and sharpened on a grinding wheel. **Note:** Sharpen ends evenly so that the blades remain balanced. However, if the cutting edge of a blade is within 3/8-inch of the wind wing, it is recommended that new blades be installed. New blades are available at your IH dealer.

Flats are provided on outside pulleys to keep spindles from rotating when blade nuts are removed. A hole is provided in center pulley and housing so a screw driver can be used to keep the center spindle from rotating.

When replacing the blades, be sure they are assembled on the friction discs so the cutting edges are in the direction of rotation with the wind wings pointed upward and the cap screws tightened securely.

Note: If the spindle nuts are removed for any reason, they should be retightened to 55 to 60 foot-pounds torque when replaced.

MOWING

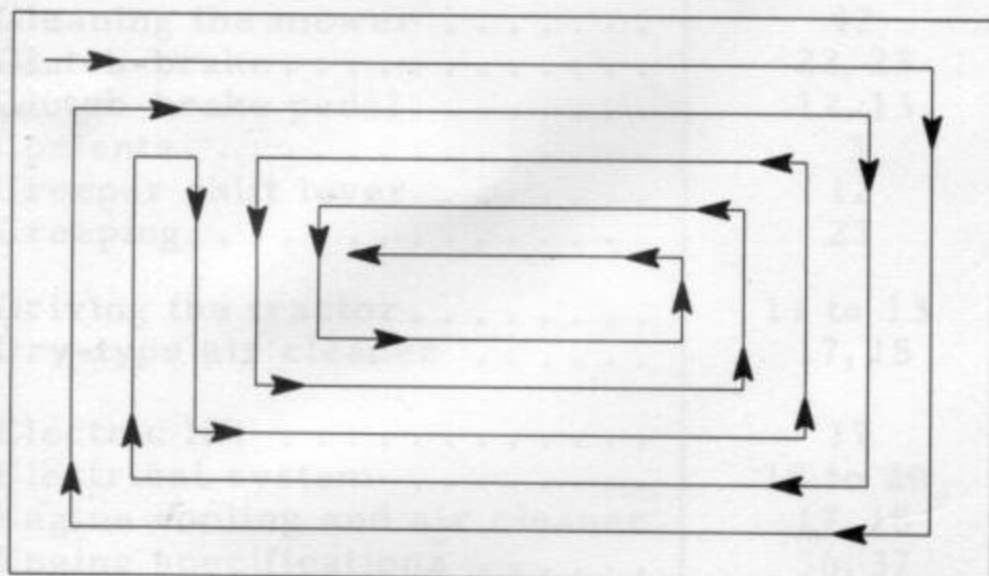

A-62943

Illust. 43

For best results it is recommended that the first two laps should be cut with the discharge being thrown towards the center. After the first two laps, reverse the direction to throw the discharge to the outside for the balance of cutting. This will give a better appearance to the lawn. **See Illust. 43.**

Do not cut the grass too short, as it will give a scalping effect and invite weed growth.

GENERAL

After 4 hours of running, check and adjust for V-belt tension. Refer to "V-BELT ADJUSTMENT" on page 42.

After the first 10 hours of operation check and retighten, if necessary, all nuts and bolts

on the machine paying particular attention to the hex. nuts securing the blades to the spindles and the cap screws at the top of the spindle. These nuts and bolts should be tightened securely. Check and retighten, if necessary, all nuts and bolts at least once a year thereafter.

Attaching and Detaching the Mower

To facilitate changing of the blades, sharpening of the blades, cleaning, etc., the mower may be detached from the tractor in the following manner:

Pull out the left and right spring loaded support pins "15" and turn them downward so ends butt against support brackets "2".

Move mower forward so left and right support clevises "3" are free of the front pivot links and lower mower to ground. Remove the V-belt from the center pulley.

Pull tractor lift handle "8" back to raise the lift linkage for clearance.

Slide the mower out from under the tractor on the right side. To aid in removing the mower, turn the tractor front wheels to the right.

To attach the mower to the tractor, reverse the above procedure.

SAFETY SUGGESTIONS

The discharge shield on the 48-inch mower must be attached at all times while operating the mower.

Children should not be allowed to operate the mower unless properly supervised.

Never place hands or feet under the mower, in the discharge chute, or near any moving parts while the tractor engine is running. Do not work on the mower with the engine running.

Never leave the tractor engine running unattended or permit it to be operated by persons not acquainted with its use and the rules for safe operation.

Be sure all stones, branches, or other objects that might be picked up and thrown by the mower blades are removed before starting to mow.

Do not allow anyone in the area opposite the discharge chute while mowing. Although the area has been supposedly cleared of foreign objects, small objects may have been overlooked and may be discharged by the mower.

Disengage the power take-off clutch before starting the tractor.

MEMORANDUM

BLADE CARE

The cutting blades must be kept sharp at all times. The blades can be sharpened on a lawnmower with a few strokes of a file or they can be removed from the mower and sharpened on a grinding wheel. Metal blades should be sharpened on the grinding wheel. However, it is important that the blade is sharpened on the cutting edge of a blade as with a file, the wind wing, it is recommended that new blades be installed. New blades are available at your U.S. dealer.

Blades are provided on our riding lawn mowers to keep blades from rotating when blades are removed. A hole is provided in center pulley and housing so a screw driver can be used to keep the center spindle from rotating.

When replacing the blades, be sure they are assembled on the tractor discharge housing the edges are in the direction of rotation with the sharp edge pointed forward and the blunt edge toward the rear. The blades should be tightened to 25 to 30 foot pounds torque.

When replacing the blades, be sure they are assembled on the tractor discharge housing the edges are in the direction of rotation with the sharp edge pointed forward and the blunt edge toward the rear. The blades should be tightened to 25 to 30 foot pounds torque.



Diagram 43

After 4 hours of running, check and adjust the V-belt tension. Refer to "V-BELT TENSIONING" on page 43.

Do not cut the grass too short, as it will damage the lawn.

After 4 hours of running, check and adjust the V-belt tension. Refer to "V-BELT TENSIONING" on page 43.

After 4 hours of running, check and adjust the V-belt tension. Refer to "V-BELT TENSIONING" on page 43.

on the machine using proper maintenance techniques. The blades should be sharpened on a grinding wheel. However, it is important that the blade is sharpened on the cutting edge of a blade as with a file, the wind wing, it is recommended that new blades be installed. New blades are available at your U.S. dealer.

Blades are provided on our riding lawn mowers to keep blades from rotating when blades are removed. A hole is provided in center pulley and housing so a screw driver can be used to keep the center spindle from rotating.

When replacing the blades, be sure they are assembled on the tractor discharge housing the edges are in the direction of rotation with the sharp edge pointed forward and the blunt edge toward the rear. The blades should be tightened to 25 to 30 foot pounds torque.

When replacing the blades, be sure they are assembled on the tractor discharge housing the edges are in the direction of rotation with the sharp edge pointed forward and the blunt edge toward the rear. The blades should be tightened to 25 to 30 foot pounds torque.

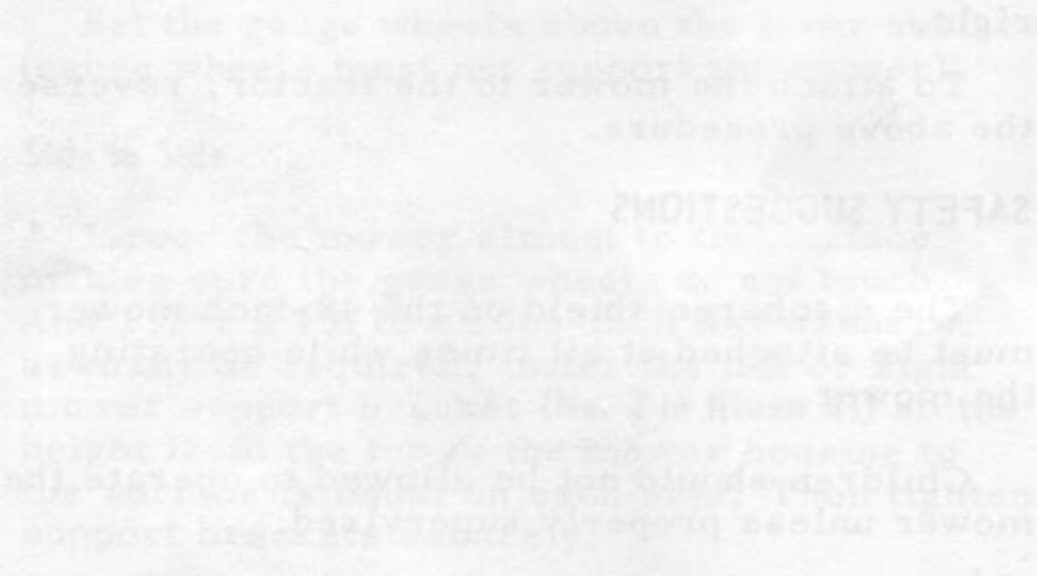

Diagram 43

After 4 hours of running, check and adjust the V-belt tension. Refer to "V-BELT TENSIONING" on page 43.

Do not cut the grass too short, as it will damage the lawn.

After 4 hours of running, check and adjust the V-belt tension. Refer to "V-BELT TENSIONING" on page 43.

After 4 hours of running, check and adjust the V-belt tension. Refer to "V-BELT TENSIONING" on page 43.

INDEX

Description	Page No.	Description	Page No.
Adjusting brakes	22 to 24	Hard to start	26
Adjusting the clutch	22, 23	Height of cut (Mower)	42
Adjusting the seat	11	Hitching trailing equipment to the tractor	13, 14
Adjusting the clutch (front power take-off)	16	Ignition switch	18
Attaching and detaching the mower	43	Inflation, tire	21
Before operating your new mower	40	Instruments and controls	5 to 7
Before operating your new tractor	8	Introduction (Mower)	40
Blade care	43	Introduction (Tractor)	Cover 1, 2
Brakes	22 to 24	Installing and removing drive belt (front power take-off)	16
Brake pedal	12, 13	Lack of power	27
Brake pedal lock	12, 13	Level adjustment (Mower)	42
Carburetor	9, 10	Lift handle	13, 14
Carburetor adjustments	9, 10	Lifting the hood	8
Care of tires	20, 21	Lights	19
Cigarette lighter	18	Locking the brake	12
Cleaning the fuel strainer and sediment bowl	9	Lubrication (Mower)	41
Cleaning the mower	42	Lubrication (Tractor)	27, 28
Clutch-brake	22, 23	Lubrication guide (Tractor)	29 to 35
Clutch-brake pedal	12, 13	Lubrication table	28
Contents	3	Motor generator	19
Creep shift lever	12	Motor generator belt	19
Creeping	27	Mounting tires on the rim	21
Driving the tractor	11 to 13	Mowing	43
Dry-type air cleaner	17, 18	Operating pressure for tires	21
Electric lift	17	Operating the creeper drive	12
Electrical system	18 to 20	Operating the electric lift	17
Engine cooling and air cleaner	17, 18	Operating the engine	8, 9
Engine specifications	36, 37	Operating the power take-off with tractor in motion	15
Engine oil	27	Operating the power take-off with tractor standing still	15
Engine oil level	27, 28	Operating the rotary mower	42
Engine operates irregularly or knocks	26	Pneumatic tires	20, 21
Engine serial number	Inside cover	Preparing the tractor for each day's work	11
Extra equipment and acces- sories	26	Rear power take-off	15
Front power take-off	16	Release lever (Hydrostatic)	13
Front wheels	21	Removing the tractor from storage	25
Front wheel toe-in	21	Rotary mowers	39 to 43
Fuel shut-off valve	9	Safety Instructions (Tractor)	4
Fuel system	9, 10	Safety starting switch	18
Fuse	20	Safety suggestions (Mower)	43, 44
Gearshift lever	5, 6, 12	Serial numbers	Inside cover
General dimensions	38	Spark plug	18
General information (Mower)	43	Specifications	35 to 38
Governor	8	Speed control lever	13

MEMORANDUM INDEX

Description	Page No.	Description	Page No.
Starting and stopping the mower	42	Tractor serial number	Inside cover
Starting the engine	9	Transmission	28, 30, 32, 34
Starting the tractor	12, 13	Transmission oil filter	28, 34
Stopping the engine	9	Trouble shooting	26, 27
Stopping the mower	42	Turning radius	21
Stopping the tractor	12, 13	V-belt (Mower)	42
Storage battery	20	View of tractor	Front cover
Taillight	19	Voltage regulator	19
Throttle lever	8	Warranty	Inside cover 3
Tire chains	21	Wheels and tires	20, 21

MEMORANDUM



NEW EQUIPMENT WARRANTY INTERNATIONAL HARVESTER FARM AND INDUSTRIAL EQUIPMENT

International Harvester Company warrants to the original purchaser with terms of sale for all industrial equipment (except tractors, combines, harvesters, or "International" line equipment) to be free from defects in material and workmanship under normal use and service. The obligation of the Company under this warranty is limited to repairing or replacing, at its expense, any parts of charge and without limitation of liability, at the place of business of a dealer of the Company authorized to service the equipment covered by this warranty, any parts hereafter, in the Company's judgment, to be defective in material or workmanship within twelve months or 1500 hours of use, whichever occurs first, after delivery to the original purchaser.

This warranty shall not apply (1) to normal wear and tear, or to any damage or deterioration resulting from use, abuse, neglect, or improper maintenance, including but not limited to, use of non-approved fuels, oils, or lubricants, or to the replacement of any parts, including but not limited to, belts, hoses, pumps, or filters, when such replacement or repair is a part of any normal maintenance program, or (2) to any items which shall have been repaired by a person not authorized by the Company for such repair.

This warranty is a service program with no charge for labor.

Such equipment, stored, neglected, or used in any way which, in the Company's opinion, adversely affects its performance.

This warranty and the Company's obligation hereunder shall be void if all warranties, express or implied, including but not limited to the limited warranty of merchantability and fitness for particular purpose, and other representations to the original purchaser and all other obligations or liabilities, including liability for incidental and consequential damages on the part of the Company or the dealer with respect to the sale or use of the items warranted.

International Harvester Company makes no representation or warranty of any character as to title and liability for or any use of new equipment now or hereafter covered by the last paragraph of this warranty, whether or not sold on or for use with such warranted items.

No person is authorized to give any other representation or assume any other liability on the Company's behalf, unless such person is authorized in writing by the Company, and no person is authorized to give any warranties or to assume any liabilities on the seller's behalf unless made known in writing by the seller.

_____ Date of Sale _____ Date of Purchase _____ Delivery Date _____

MEMORANDUM

Description	Page No.	Description	Page No.
Starting and stopping the mower	42	Tractor serial number	Inside cover
Starting the engine	9	Transmission	28, 30, 32, 34
Starting the tractor	12, 13	Transmission oil filter	28, 34
Stopping the engine	9	Trouble shooting	26, 27
Stopping the mower	42	Turning radius	21
Stopping the tractor	12, 13	V-belt (Mower)	42
Storage battery	20	View of tractor	Front cover
Tail light	19	Voltage regulator	19
Throttle lever	8	Warranty	Inside cover 2
Tire chains	21	Wheels and tires	20, 21



NEW EQUIPMENT

WARRANTY

INTERNATIONAL HARVESTER

FARM and INDUSTRIAL EQUIPMENT

International Harvester Company warrants to the original purchaser each item of new farm and industrial equipment bearing either the identification "McCormick" or "International", or a combination thereof, to be free from defects in material and workmanship under normal use and service. The obligation of the Company under this warranty is limited to repairing or replacing as the Company may elect, free of charge and without charge for installation, at the place of business of a dealer of the Company authorized to handle the equipment covered by this warranty, any parts that prove, in the Company's judgment, to be defective in material or workmanship within twelve months or 1500* hours of use, whichever occurs first, after delivery to the original purchaser.

This warranty shall not apply (1) to normal maintenance services or adjustments, including but not limited to fuel system cleaning, engine tune-up, brake inspection or adjustment, nor to the replacement of spark plugs, ignition points, condensers or filters when such replacements are made as a part of any normal maintenance service; nor (2) any items which shall have been operated in a manner not recommended by the Company nor which shall have

been repaired, altered, neglected, or used in any way which, in the Company's opinion, adversely affects its performance.

This warranty and the Company's obligation thereunder is in lieu of all warranties, express or implied, including without limitation, the implied warranties of *merchantability and fitness for particular purpose*, all other representations to the original purchaser and all other obligations or liabilities, including liability for incidental and consequential damages on the part of the Company or the seller with respect to the sale or use of the items warranted.

International Harvester Company makes no representations or warranties of any character as to tires and tubes nor to any item of new equipment not specifically covered by the first paragraph of this warranty, whether or not sold on or for use with such warranted items.

No person is authorized to give any other warranties or to assume any other liability on the Company's behalf unless made or assumed in writing by the Company, and no person is authorized to give any warranties or to assume any liabilities on the seller's behalf unless made or assumed in writing by the seller.

*2000 hours on a crawler tractor with 65 or more net flywheel horsepower.

Description

Serial Number (If any)

Delivery Date

INTERNATIONAL HARVESTER COMPANY



For Your Protection

Use IH Parts

TO THE OWNER—

You have just purchased one of the finest pieces of equipment available today. You can look forward to years of good service because International Harvester machines are designed better and built better to last longer.

When you need to purchase replacement parts or have your equipment serviced, we will be here, ready to serve you.

We stock genuine IH parts—the parts that are designed for your equipment, not just made for it.

We also offer you IH Blue Ribbon Service—the service that puts your equipment back to work in minimum time at an economical cost. We are here to serve you—call on us in the future.

Sincerely,

Your IH dealer