

**INTERNATIONAL[®]
CUB CADET[®]
86, 108, 128, 129
149, and 169
TRACTORS and
ROTARY MOWERS**

INTERNATIONAL[®]

OPERATOR'S MANUAL

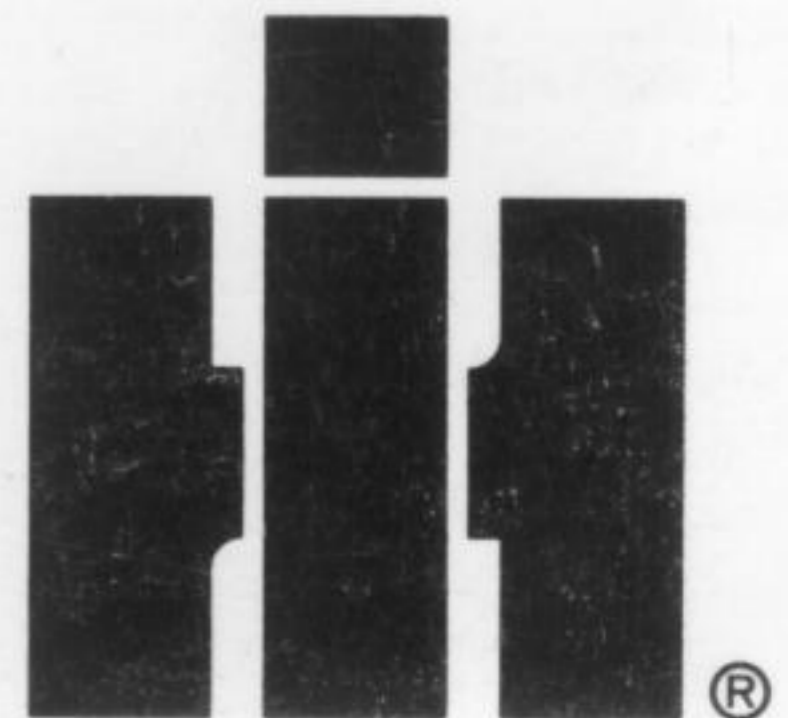

To The Owner

Assembled in this manual are operation, lubrication, and maintenance instructions for the International Cub Cadet 86, 108, 128, 129, 149, and 169 Tractors. The material has been prepared in detail to help you better understand the correct care and efficient operation of your tractor. Before you operate the tractor, study this manual carefully. New copies may be ordered from your dealer at a nominal price.

Your local International Harvester dealer is interested in the performance you receive from this tractor. He has factory-trained servicemen, informed in the latest method of servicing tractors, modern tools, and original-equipment IH service parts which assure proper fit and good performance.

The International Cub Cadet 129, 149, and 169 Tractors have a hydrostatic drive. It is the best hydraulic drive unit available and will require minimum service if recommended operation and maintenance procedures are followed. Should you

have difficulties with the unit consult your International Harvester dealer. **UNDER NO CIRCUMSTANCES SHOULD YOU ATTEMPT TO SERVICE THESE UNITS YOURSELF.** Only your dealer is authorized to repair or replace units on this drive under the terms of the warranty. Should you desire additional information not found in this manual, contact your International Harvester dealer.

The International Cub Cadet 86, 108, and 128 Tractors have a conventional clutch and transmission.

To obtain top performance and assure economical operation the tractor should be inspected, depending on its use, periodically, or at least once a year, by your International Harvester dealer.

When in need of parts, always specify the model, chassis, and engine serial numbers, including the prefix and suffix letters. Write these serial numbers in the space provided on page 4.

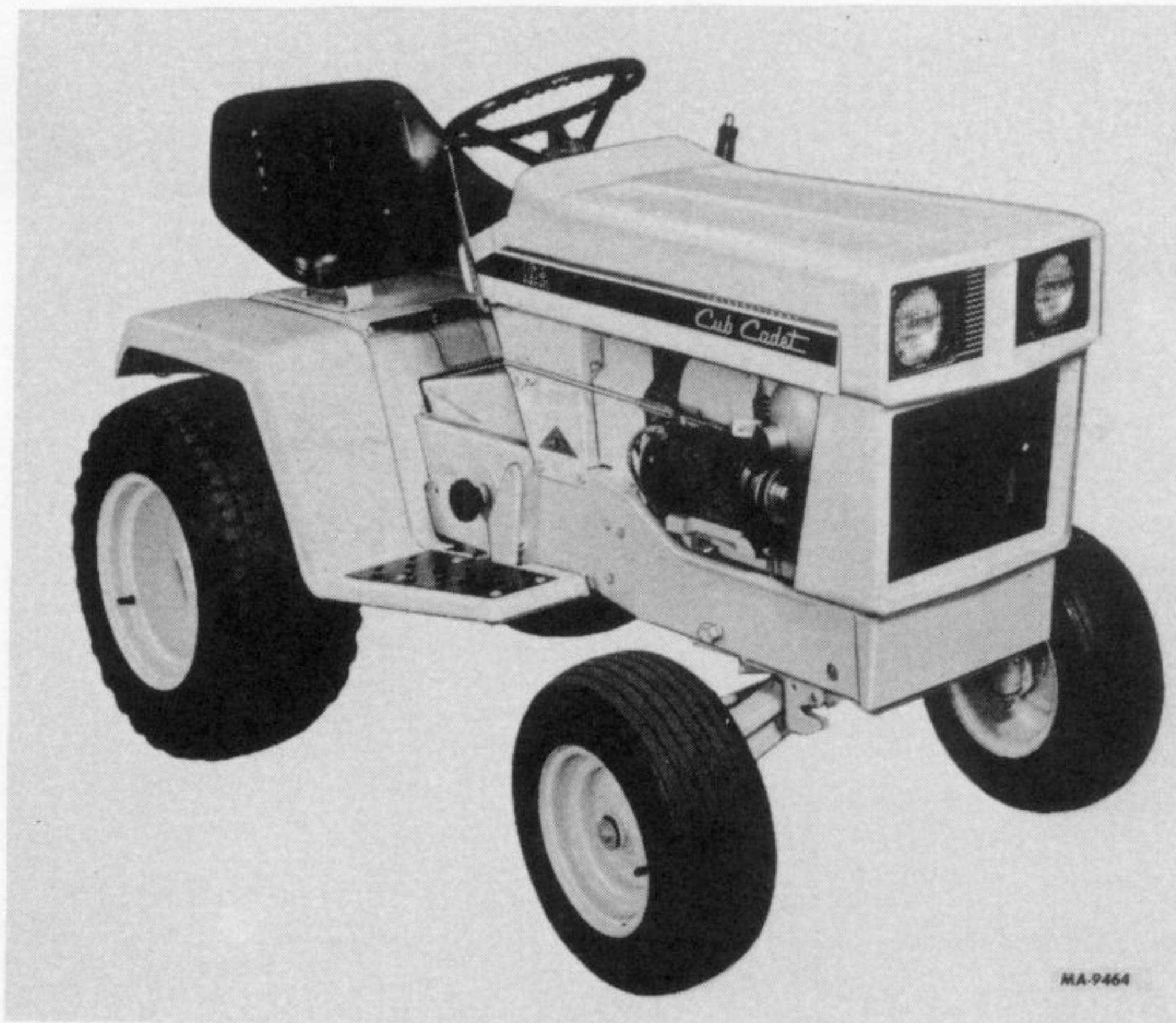

TECHNICAL PUBLICATIONS AVAILABLE

Cut Along This Line

TO THE OWNER
Your International Harvester Dealer and his factory trained servicemen are best qualified to service your equipment. Up-to-date instructions and adequate special tools are also a part of your Dealer's service facilities.

CONTENTS
This Operator's Manual was prepared to instruct you in proper and safe operation and maintenance of your equipment. If you desire additional information you may purchase Service Manuals and/or Parts Catalogs. Copies of the Operator's Manual are also available.

WORK SAFELY - FOLLOW THESE RULES
Fill out this order blank and forward together with your check or money order in the appropriate amount (U.S. Funds) to:

International Harvester Company

PRINTING AND DISTRIBUTION SERVICES

807 Blackhawk Drive

Westmont, Illinois 60559

Attention: Cashier

Cut Along This Line

Title	Number	Qty.	Price Each
Operator's Manual			
International Cub Cadet 86, 108, 128, 129, 149, and 169 Tractors and Rotary Mowers	1 084 322R1 Rev. 1		3.30
Parts Catalog			
International Cub Cadet Tractors and Equipment	TC-157		7.50
Service Manuals			
International Cub Cadet 86, 108, 109, 128, 129, 149, and 169 Tractors and IH Equipment	GSS-1439		6.00
Listing of Agricultural/Industrial Equipment Service Manuals . . .	GSS-5042		1.00

TOTAL _____

Please Print

Name _____

Street Address _____

City _____

State _____

Zip Code _____

Date _____

Signed _____

Do not send cash or stamps

Prices subject to change without notice.

CONTENTS

TO THE OWNER	Inside cover	DRIVING THE TRACTOR	11 to 15
SERVICE MANUAL INFORMATION		Adjusting the seat	
		Clutch and brake pedal	
		Locking the brake	
EXTRA EQUIPMENT AND CONTENTS	1 to 3	International Cub Cadet 86, 108 and 128 Tractors	
SERIAL NUMBER LOCATION	4	Clutch-brake pedal	
		Gearshift lever	
INTRODUCTION	4	Starting the tractor	
		Stopping the tractor	
WORK SAFELY - FOLLOW THESE RULES		Creep shift lever	
		Operating the creeper drive	
		International Cub Cadet 129, 149 and 169 Tractors	
LUBRICATION GUIDE		Stopping the tractor	
INSTRUMENTS AND CONTROLS	6, 7	Brake pedal	
		Speed control lever	
BEFORE OPERATING YOUR NEW TRACTOR	8	Starting the tractor	
		Release lever	
		Stopping the tractor	
OPERATING THE ENGINE	8, 9	EQUIPMENT LIFT HANDLE	15
Throttle lever		Height adjustment	
Governor		HITCHING EQUIPMENT TO THE TRACTOR	16
Lifting the hood		Drawbar	
Starting the engine		Three-point hitch	
Stopping the engine			
FUEL SYSTEM	10, 11		
Fuel shut-off valve			
Carburetor adjustments			

CONTENTS

<p>REAR POWER TAKE-OFF 17</p> <p style="padding-left: 20px;">Operating the rear power take-off with the tractor standing still</p> <p style="padding-left: 20px;">Operating the rear power take-off with the tractor in motion</p> <p>FRONT POWER TAKE-OFF 18</p> <p style="padding-left: 20px;">Operating the front power take-off clutch</p> <p style="padding-left: 20px;">Adjusting the power take-off clutch</p> <p>ELECTRIC LIFT 18, 19</p> <p>HYDRAULIC LIFT</p> <p>ENGINE COOLING AND AIR CLEANER 21</p> <p style="padding-left: 20px;">Engine cooling</p> <p style="padding-left: 20px;">Dry type air cleaner</p> <p>ELECTRICAL SYSTEM 21 to 24</p> <p style="padding-left: 20px;">Ignition switch</p> <p style="padding-left: 20px;">Safety starting switch</p> <p style="padding-left: 20px;">Charge indicator</p> <p style="padding-left: 20px;">Hour meter</p> <p style="padding-left: 20px;">Spark plug</p>	<p style="padding-left: 20px;">Motor generator</p> <p style="padding-left: 20px;">Motor generator belt</p> <p style="padding-left: 20px;">Lights</p> <p style="padding-left: 20px;">Fuse</p> <p>PNEUMATIC TIRES 24, 25</p> <p style="padding-left: 20px;">Rear tires</p> <p style="padding-left: 20px;">Care of tires</p> <p style="padding-left: 20px;">Inflation</p> <p style="padding-left: 20px;">Operating pressure for tires</p> <p style="padding-left: 20px;">Mounting tires on the rim</p> <p style="padding-left: 20px;">Rear wheel weights</p> <p style="padding-left: 20px;">Tire chains</p> <p style="padding-left: 20px;">Overloading</p> <p>FRONT WHEELS 26</p> <p style="padding-left: 20px;">Front quick attaching latch</p> <p style="padding-left: 20px;">Front wheel toe-in</p> <p style="padding-left: 20px;">Turning radius</p> <p>CLUTCH-BRAKE</p> <p style="padding-left: 20px;">International Cub Cadet 86, 108 and 128 Tractors 27, 28</p> <p style="padding-left: 20px;">Adjusting the clutch</p> <p style="padding-left: 20px;">Adjusting the brakes</p> <p>BRAKES</p> <p style="padding-left: 20px;">International Cub Cadet 129, 149 and 169 Tractors 29</p> <p style="padding-left: 20px;">Adjusting the brakes</p>
---	--

CONTENTS

STORING THE TRACTOR	30	TO THE OWNER	46
Removing from storage			
EXTRA EQUIPMENT AND ACCESSORIES	31	INTRODUCTION	47
TROUBLE SHOOTING	31, 32	WORK SAFELY - FOLLOW THESE RULES	
LUBRICATION	33, 34	OPERATING YOUR MOWER	48
LUBRICATION TABLE	35	ADJUSTING AND OPERATING	49 to 55
LUBRICATION GUIDE		Starting the mower	
International Cub Cadet 86, 108 and 128 Tractors	36 to 38	Stopping the mower	
LUBRICATION GUIDE		Level adjustment	
International Cub Cadet 129, 149 and 169 Tractors	39 to 41	V-belt	
SPECIFICATIONS	41 to 44	Height of cut	
OPERATING INSTRUCTIONS INTERNATIONAL ROTARY MOWERS	45 to 55	Cleaning	
		Blade care	
		Lubrication	
		General	
		Mowing	
		SETTING UP	57 to 64

SERIAL NUMBER LOCATION

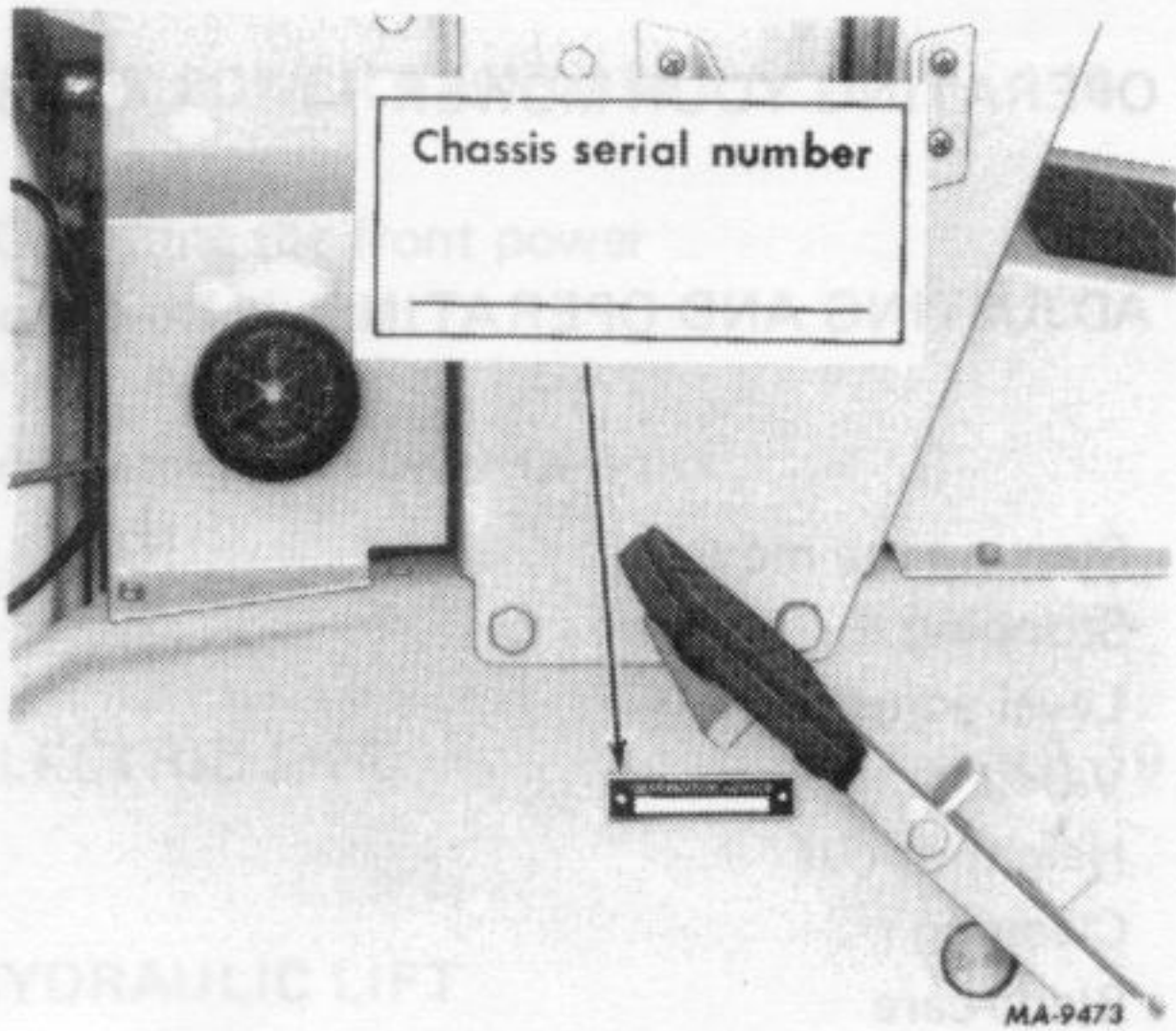
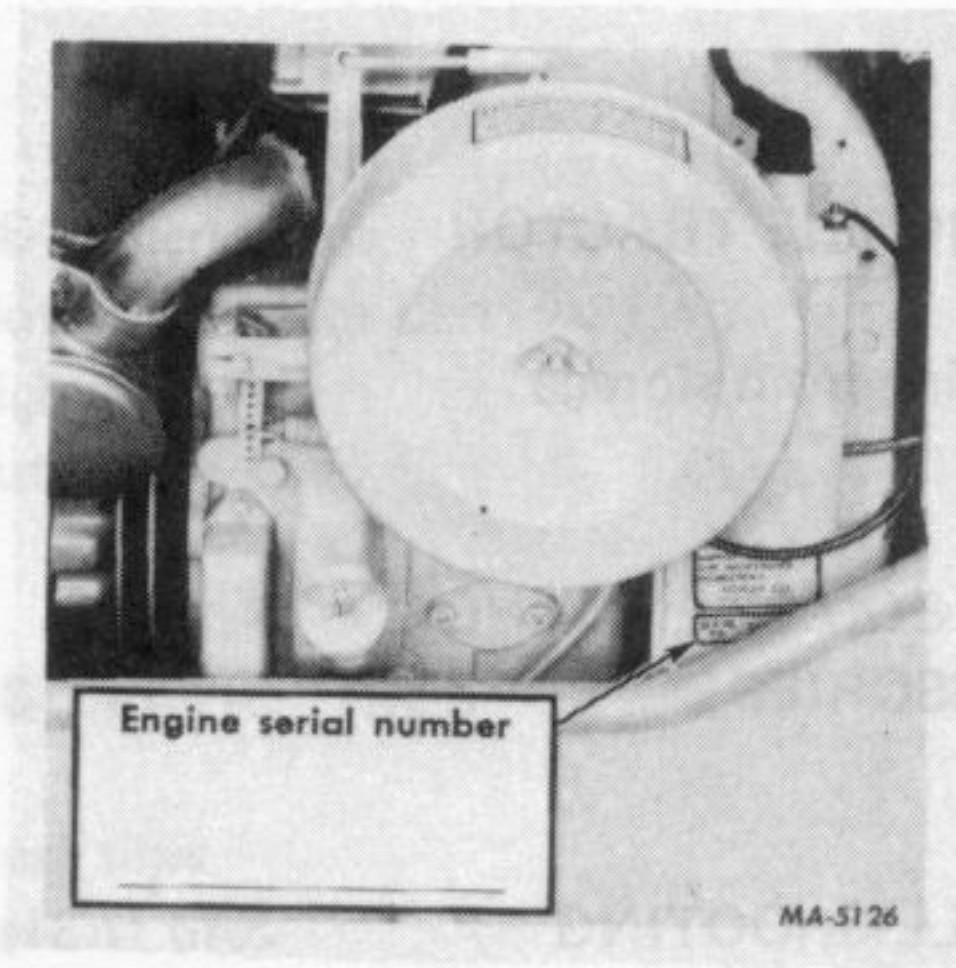
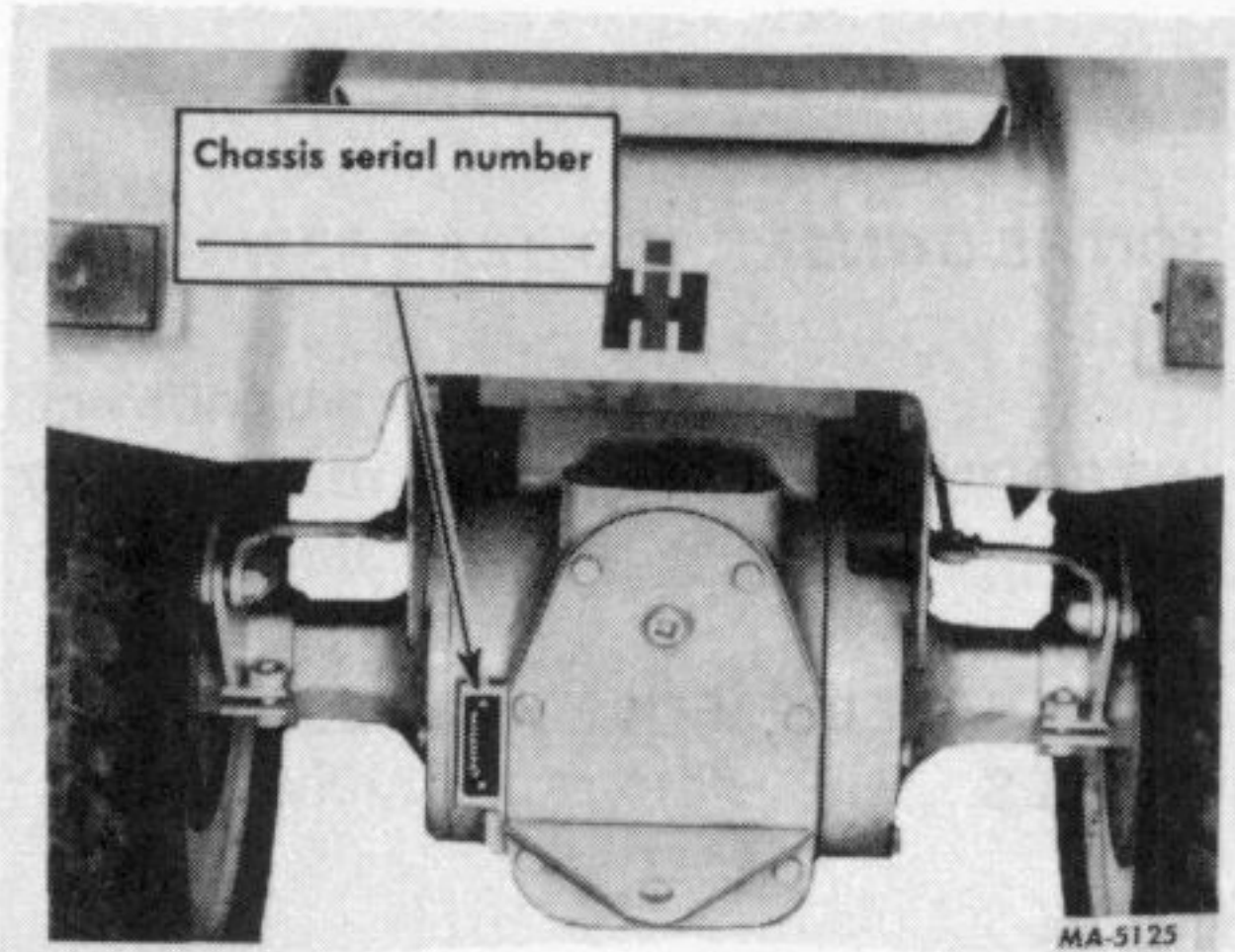

Serial No. 500 718 and above.

MODEL _____

DELIVERY DATE _____

INTRODUCTION

A variety of extra equipment and accessories is available. Where operating and maintaining instruction is required, it is included in the instruction for operating and maintaining the tractor. Disregard the instructions for equipment not on your tractor.

LEFT and RIGHT indicate the left and right sides of the tractor when facing forward in the driver's seat. Reference to FRONT indicates the grille end of the tractor; to REAR the drawbar end.

This manual is for tractors with Serial No. 507 000 and above.

WORK SAFELY – FOLLOW THESE RULES



This symbol is used to call your attention to instructions concerning your personal safety. Be sure to observe and following these instructions.

Disengage all clutches and shift into neutral before starting the engine.

Disengage power to any attachments and stop engine before leaving operator's seat or making any repairs or adjustments.

Know the controls and how to stop quickly – **READ THE OPERATOR'S MANUAL.**

Do not allow children or adults to operate the equipment without proper instruction.

Clear work area of objects which might be picked up and thrown.

Disengage power to any attachment when transporting or not in use.

Do not carry passengers or give rides. Keep children, pets, and by-standers a safe distance away.

Always disengage the power take-off, shift transmission into neutral, set the parking brake, stop the engine, and remove ignition key when leaving the machine unattended.

Reduce speed on slopes and in sharp turns to prevent tipping or loss of control.

Stay alert for holes in terrain and other hidden hazards.

Don't stop or start suddenly when going uphill or downhill.

Use care when pulling loads or using heavy equipment: – A. Use only approved hitch points. B. Limit loads to those you can safety control. C. Don't turn too sharp, and use care when backing. D. Use counterweight or wheel weights when suggested in Operator's Manual.

Watch out for traffic when crossing or near roadways.

When using any attachments, never direct discharge of material toward bystanders nor allow anyone near the machine while in operation.

Handle gasoline with care – it is highly flammable: – A. Use approved gasoline container. B. Never remove the fuel tank cap or fill the fuel tank when the engine is running, is hot, or **indoors**. Also, do not smoke when working around inflammable fuel. Wipe up spilled gasoline. C. Replace gasoline cap securely. D. Open doors if engine is running in a garage – exhaust gases are dangerous.

Keep machine in good operating condition and keep safety devices in place. Use guards or shields as instructed in Operator's Manual.

It is recommended that the machine be stopped and inspected for damage after striking a foreign object and that any damage be repaired before restarting and operating the machine.

Always depress the brake pedal and set the brake pedal lock before working on the machine. Disengage all implements and shift the transmission into neutral.

INSTRUMENTS AND CONTROLS

Your Cub Cadet Tractor has been safety engineered. Thoroughly acquaint yourself with all the instruments and controls before attempting to start or operate the tractor.

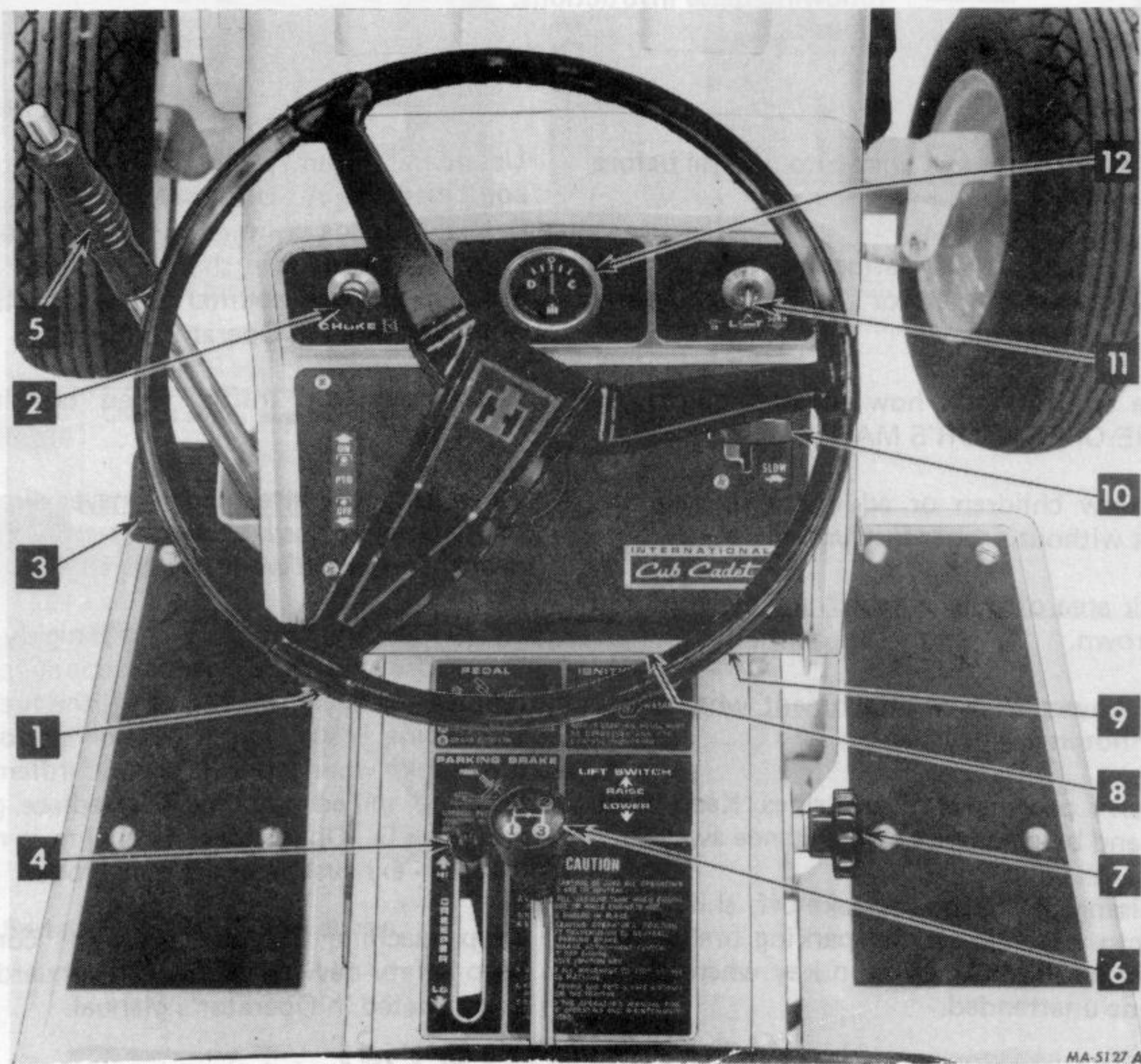

Instruments and controls on the International Cub Cadet 86, 108, and 128 Tractors.

- | | |
|--------------------------------------|---------------------|
| 1. Brake pedal lock | See page 12 |
| 2. Choke control button | See page 9 |
| 3. Clutch-brake pedal | See pages 12 and 13 |
| 4. Creeper shift lever* | See page 13 |
| 5. Front power take-off clutch lever | See page 18 |
| 6. Gearshift lever | See page 13 |
| 7. Lift handle cam stop | See page 15 |
| 8. Lighting switch button* | |
| 9. Ignition switch | See page 21 |
| 10. Throttle | See page 8 |
| 11. Electric lift control switch* | See page 18 and 19 |
| 12. Charge indicator | See page 22 |

* Optional Equipment

INSTRUMENTS AND CONTROLS

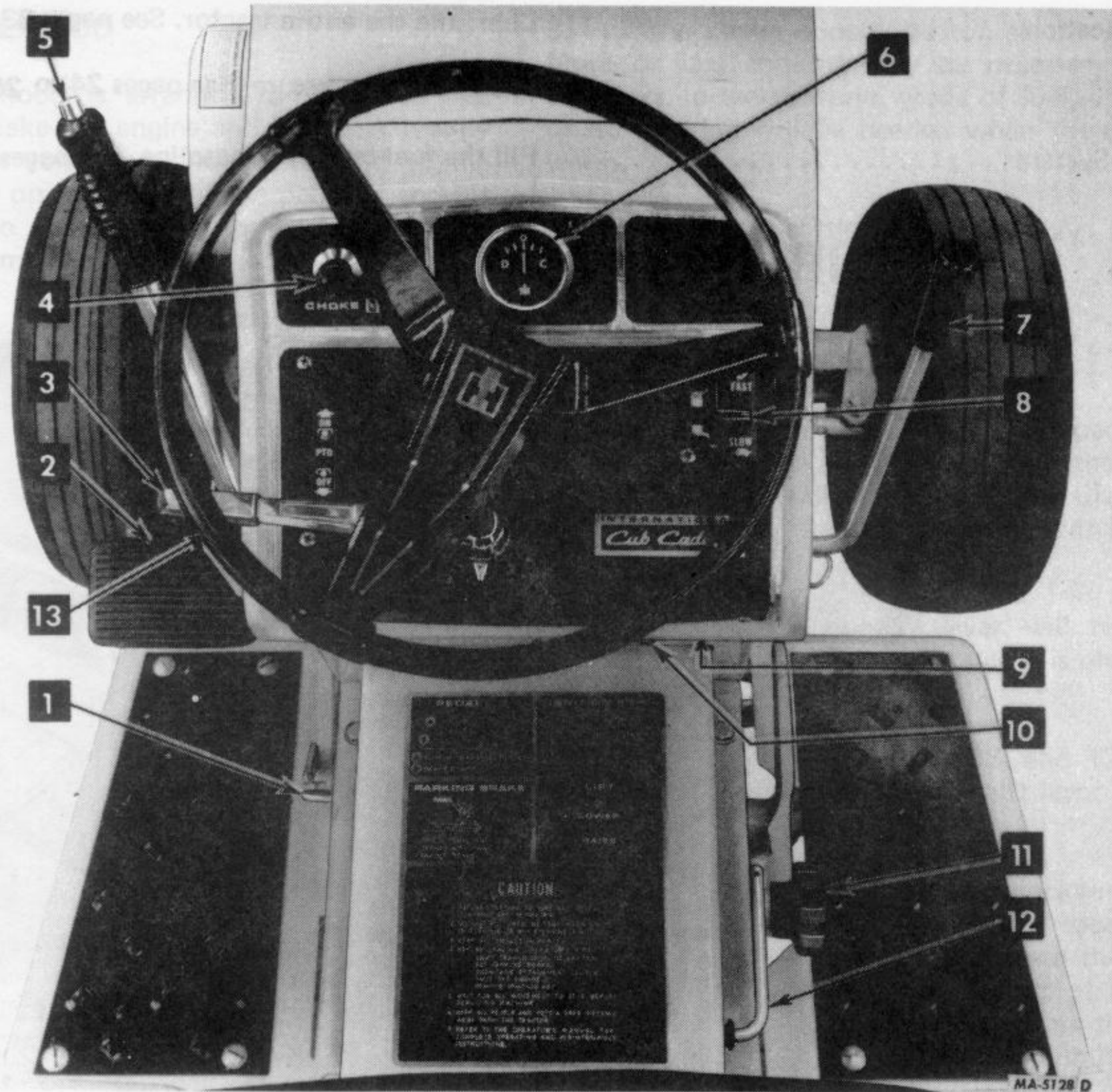

Instruments and controls on the International Cub Cadet 129, 149, and 169 Tractors.

1. Brake pedal lock	See page 14
2. Brake pedal	See page 14
3. Speed control lever	See page 14
4. Choke control button	See page 9
5. Front power take-off clutch lever	See page 18
6. Charge indicator	See page 22
7. Hydraulic lift control handle	See page 20
8. Throttle lever	See page 8
9. Ignition switch	See page 21
10. Lighting switch button* (Standard on Models 149 and 169)	
11. Lift handle cam stop	See page 15
12. Release lever	See page 15
13. Hour meter— (Standard on Model 169 only)	See page 22
Electrict lift* (Not shown.) Available on all but the Model 149 and 169 Tractors.	

* Optional Equipment

BEFORE OPERATING YOUR NEW TRACTOR

- Lubrication Lubricate the entire tractor. See pages 33 to 41
- Tires Check the air pressure. See pages 24 to 26
- Fuel System Fill the fuel tank with gasoline. See pages 10 and 11.

OPERATING THE ENGINE

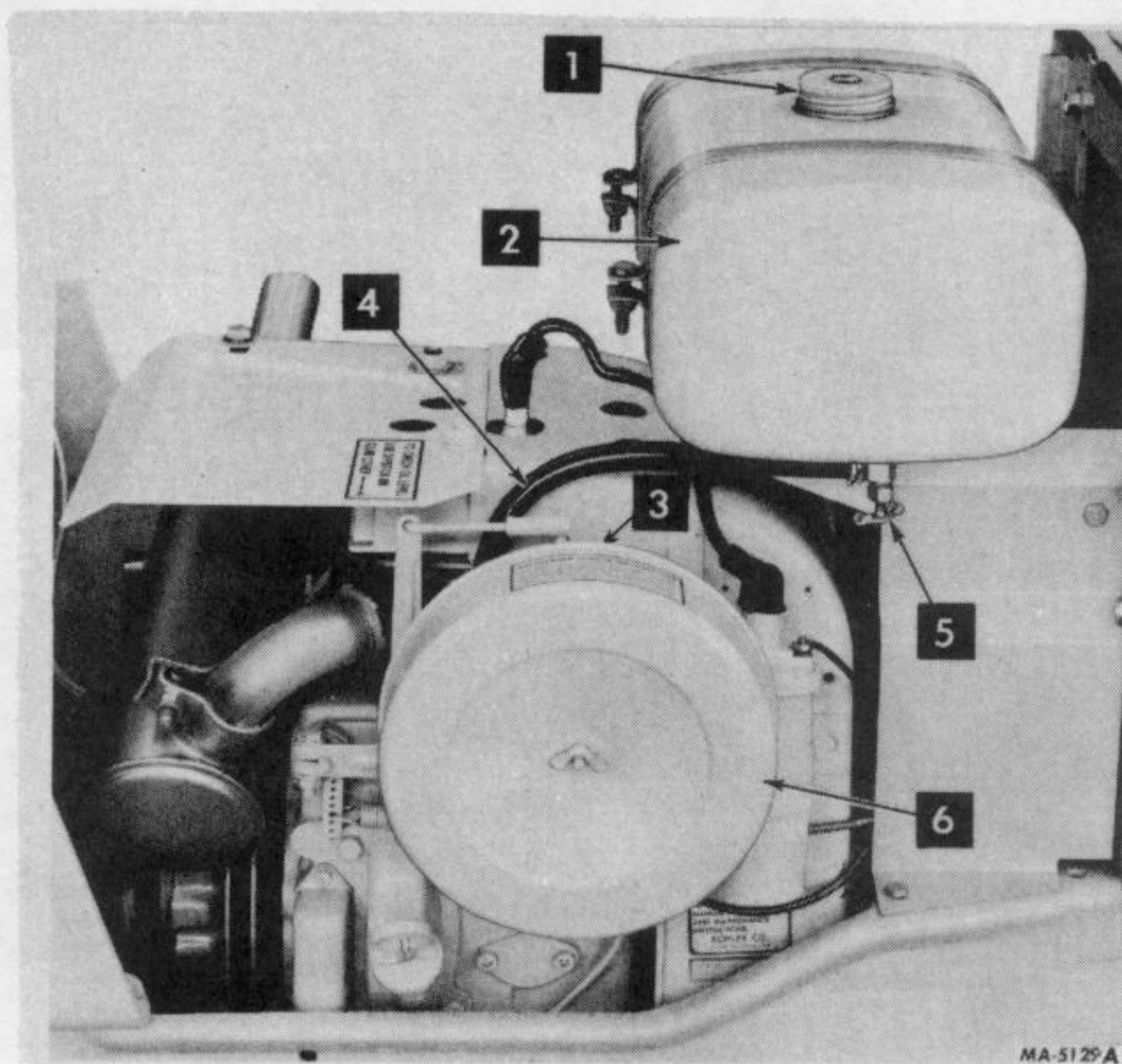

- | | |
|--------------------------|------------------------|
| 1. Fuel tank filler cap | 4. Fuel line |
| 2. Fuel tank | 5. Fuel shut-off valve |
| 3. Carburetor (not seen) | 6. Air cleaner |

Fuel System.

THROTTLE LEVER

This lever controls the speed of the engine. When set in a given position, it will maintain a uniform engine speed.

When using power take-off operated equipment, best performance is achieved with the throttle lever in the "FAST" position.

GOVERNOR

The governor is set at the time the engine is assembled and should not require readjustment unless the governor arm is removed or loosened from the governor shaft. Consult your International Harvester dealer if the governor does not function properly.

OPERATING THE ENGINE

LIFTING THE HOOD

The tractor hood is arranged to swing up and forward to make the engine and fuel tank readily accessible. To raise the hood take hold of the spring latches on each side of the pedestal and lift up and out to release the spring latches from the hood crossmember.

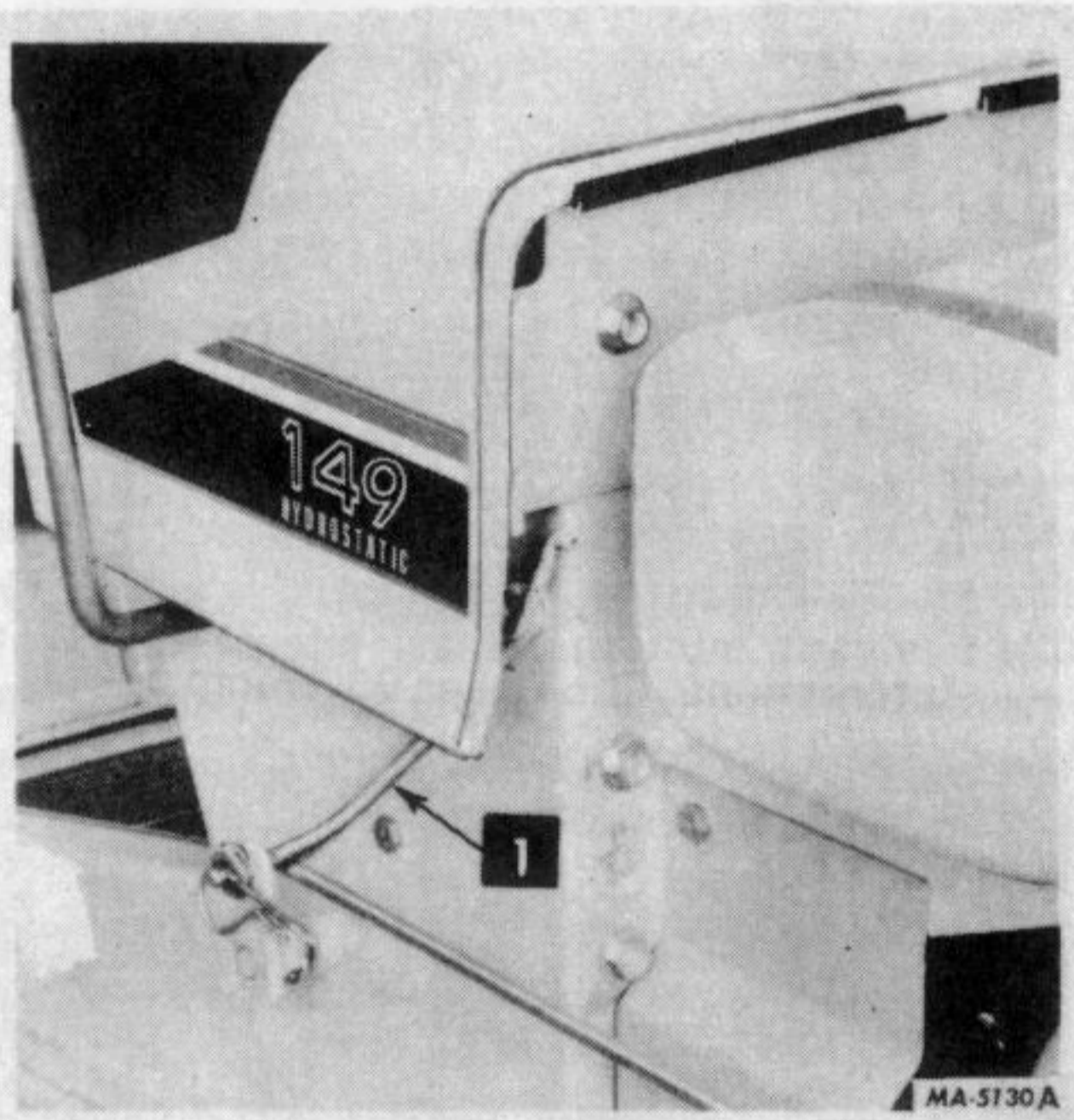

1. Hood spring latch
(one on each side)

STARTING THE ENGINE

1. Be sure there is an adequate supply of gasoline in the fuel tank.



CAUTION! Never remove the fuel tank cap or fill the fuel tank when the engine is running, is hot, or indoors. Also, do not smoke when working around inflammable fuel.

2. Be sure the fuel shut-off valve is open.

3. Pull the choke control button all the way out. More or less choking may be necessary due to variations in temperature, grade of fuel, etc. Little or no choking will be needed when the engine is warm.

4. Place the throttle lever half-way between "SLOW" and "FAST".

5. Place the throttle lever half-way between "SLOW" and "FAST".

6. To start the engine the clutch-brake pedal must be pressed all the way down and the power take-off clutch handle must be in the disengaged position to actuate the safety starting switches.

On the International Cub Cadet 129, 149, and 169 Tractors the speed control lever will return to neutral when the clutch-brake pedal is pressed all the way down.

International Cub Cadet 86, 108, and 128 Tractors: Check to see that the gearshift lever is in the neutral position.

All Models: Turn the ignition key clockwise to the "START" position and release it as soon as the engine starts; however do not operate the motor generator for more than 30 seconds at any one time. If the engine does not start within this time, turn the key "OFF" and wait a few minutes, then try again.

5. After the engine starts, slowly release the clutch-brake pedal and gradually push the choke control button all the way in. Do not use the choke to enrich the fuel mixture, except when necessary to start the engine.

STOPPING THE ENGINE

Move the throttle lever to the "SLOW" position and allow the engine to idle for a short time before stopping. Then turn the key to the "OFF" position.

BEFORE OPERATING FUEL SYSTEM NEW TRACTOR

FUEL SYSTEM

This engine is designed to operate on leaded gasoline with a 93 minimum octane rating or on unleaded or low lead gasoline with a 91 minimum octane rating (Research Method).

The use of unleaded gasoline will lengthen spark plug and valve life, maintain engine performance longer, and reduce rust and corrosion of engine while stored.

The fuel tank filler cap has an air vent. Keep the vent open at all times to assure proper flow of the fuel.

 **CAUTION!** Never remove the fuel tank cap or fill the fuel tank when the engine is running, hot, or when near an open flame. Do not smoke when working around inflammable fuel, as the air around the tractor is mixed with a highly explosive vapor. When pouring fuel, keep the container or hose nozzle in contact with the metal of the fuel tank to avoid the possibility of an electric spark igniting the gas. Do not spill gasoline on a hot engine.

FUEL SHUT-OFF VALVE

Be sure the shut-off valve under the fuel tank is open. Screw out the needle stem (shut-off valve) until the seat on the stem is tight against the stop to prevent leakage or seepage when the valve is in its full-open position.

CARBURETOR ADJUSTMENTS

The carburetor is adjusted at the factory and under normal operation conditions it will not require readjusting. However, if the engine does not operate properly, it is recommended a new air cleaner be installed before performing carburetor adjustments. If this adjustment has been disturbed for any reason, proceed as follows:

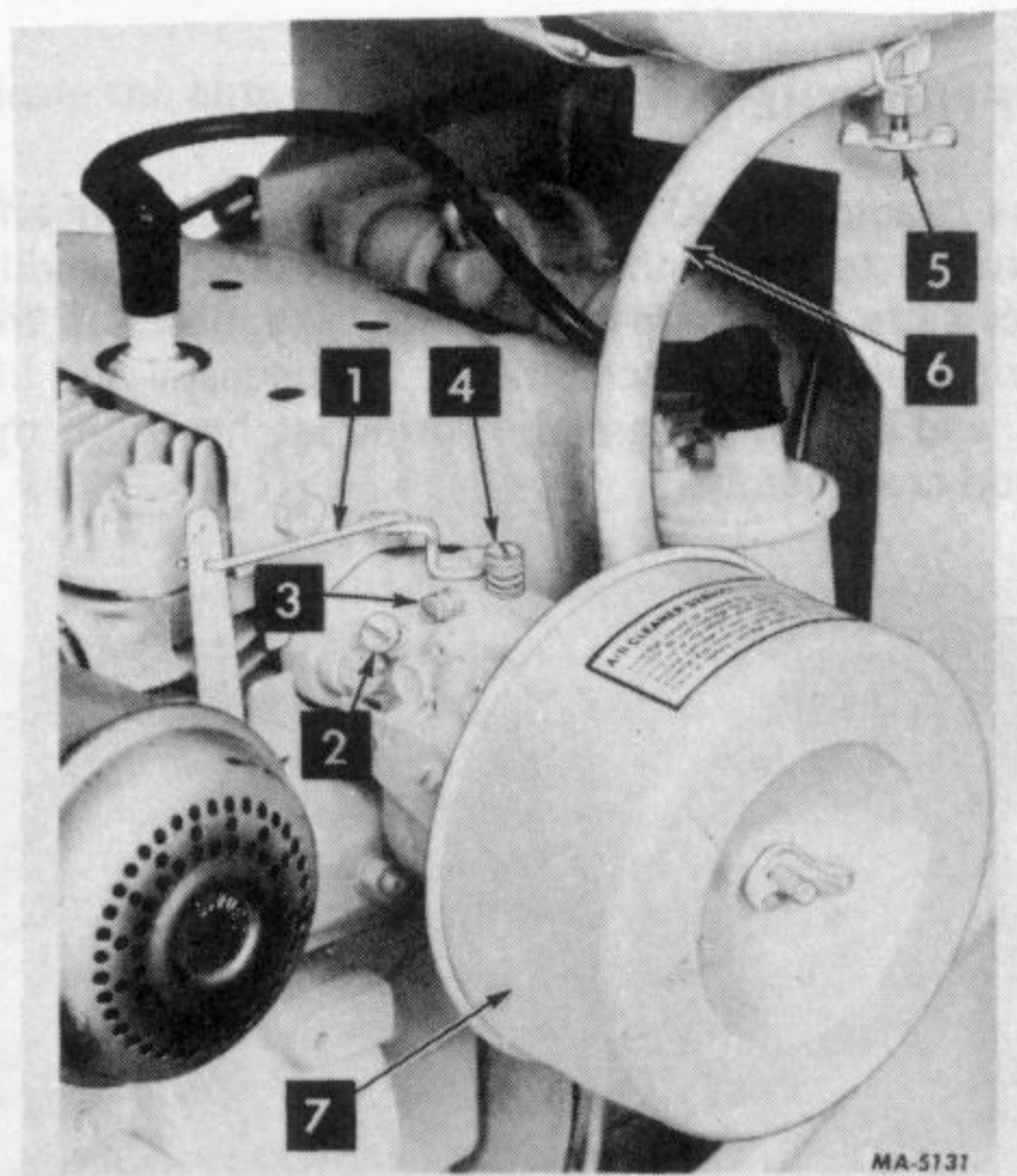

International Cub Cadet 86 Tractor.

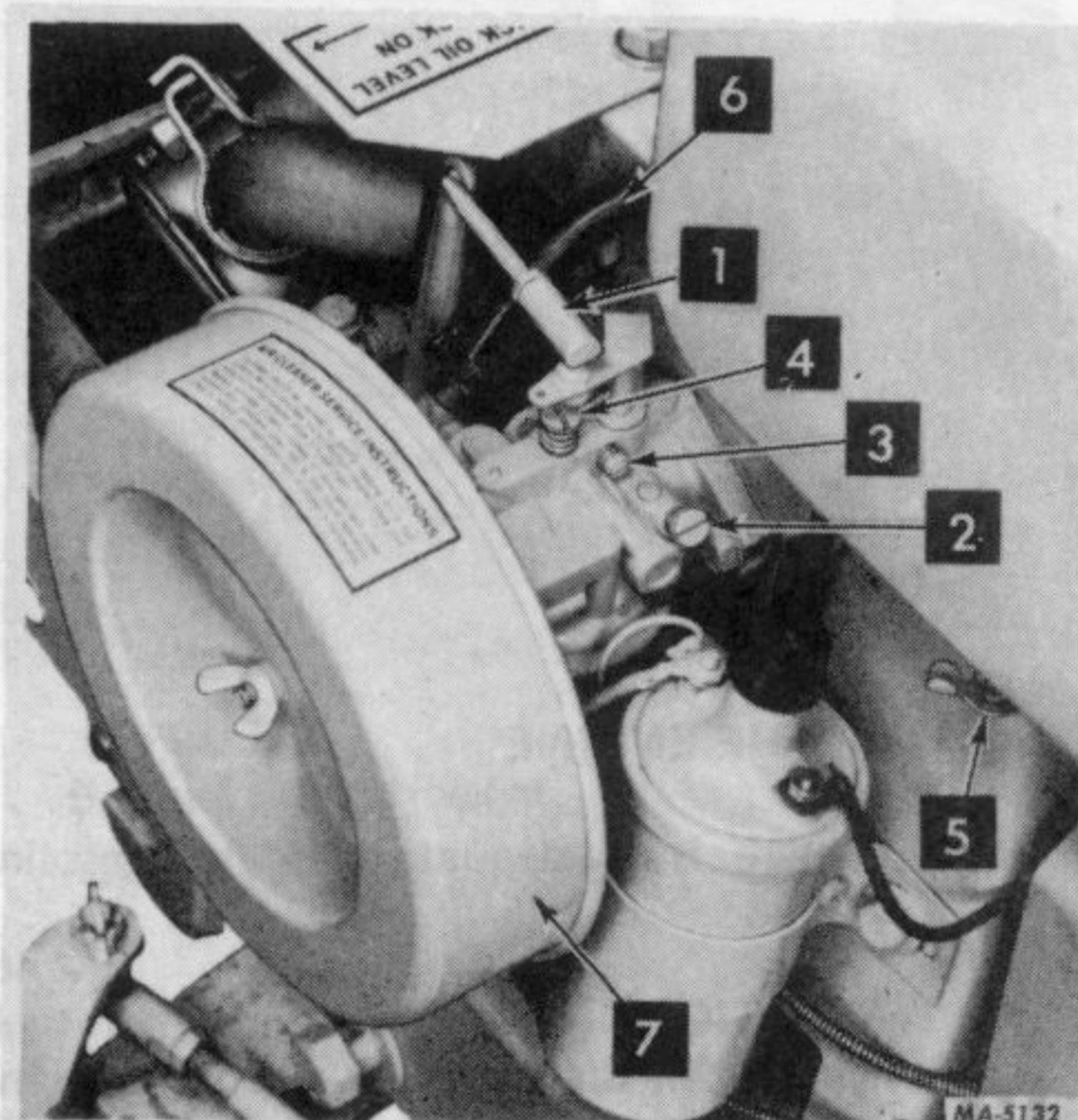

1. Governor control rod
2. Idle adjustment screw
3. Throttle stop screw
4. High speed adjustment screw
5. Fuel shut-off valve
6. Fuel line
7. Air cleaner

International Cub Cadet 108, 128, 129, 149, and 169 Tractors.

FUEL SYSTEM

CARBURETOR ADJUSTMENTS — Continued



CAUTION! Be sure the brake pedal is in the locked position, transmission is in neutral, and the mower is disengaged before adjusting the carburetor.

Adjusting the High-Speed Adjustment Screw

Turn the high speed adjustment screw counterclockwise approximately two turns from the closed position and start the engine.

Be sure the choke is fully open when adjusting.

After the engine has reached normal operating temperature, place the throttle lever in the fast position and turn the high speed adjustment screw clockwise to the leanest mixture that will allow satisfactory acceleration and steady governor operation. Then, turn counterclockwise to the richest mixture that allows satisfactory operation. The difference between the rich and lean points is about 1/2 turn. Set the mixture to the rich end of this range.

If the engine misses and backfires under load, the high speed mixture is too lean. The high speed adjustment screw must be turned counterclockwise 1/4 turn at a time until the condition is corrected.

If the engine shows a sooty exhaust and is sluggish under load, the high speed mixture is too rich. The high speed adjustment screw must be turned clockwise 1/4 turn at a time until the condition is corrected.

Adjusting the Idle Adjustment Screw

After the high speed adjustment screw is adjusted, it may be necessary to readjust the idle adjustment screw as each affects the other.

Close the idle adjustment screw to its seat by turning it clockwise; then open it one turn. Start the engine and operate it at fast idling speed (without any load) until thoroughly warm.

While the engine is running at fast idle speed, it is advisable to screw in the throttle stop screw a few turns to keep the engine from stopping when the throttle lever is moved to the fully retarded "SLOW" position. The engine will then be idling at a fairly high speed and the throttle stop screw can be backed out a little at a time until the desired idle speed is obtained.

If the engine misses or rolls while backing out the throttle stop screw, the idle adjustment screw may be adjusted in or out until the engine operates smoothly. Speed up the engine for a few seconds; then recheck the idle adjustment. A slight adjustment in or out will give the smoothest idle.

DRIVING THE TRACTOR

PREPARING THE TRACTOR FOR EACH DAY'S WORK

Check the crankcase oil level and add new oil if necessary. See pages 34 and 35.

Clean the air cleaner element if necessary. See page 21.

Inspect the tires for general condition. See page 26

DRIVING THE TRACTOR

FUEL SYSTEM

ADJUSTING THE SEAT

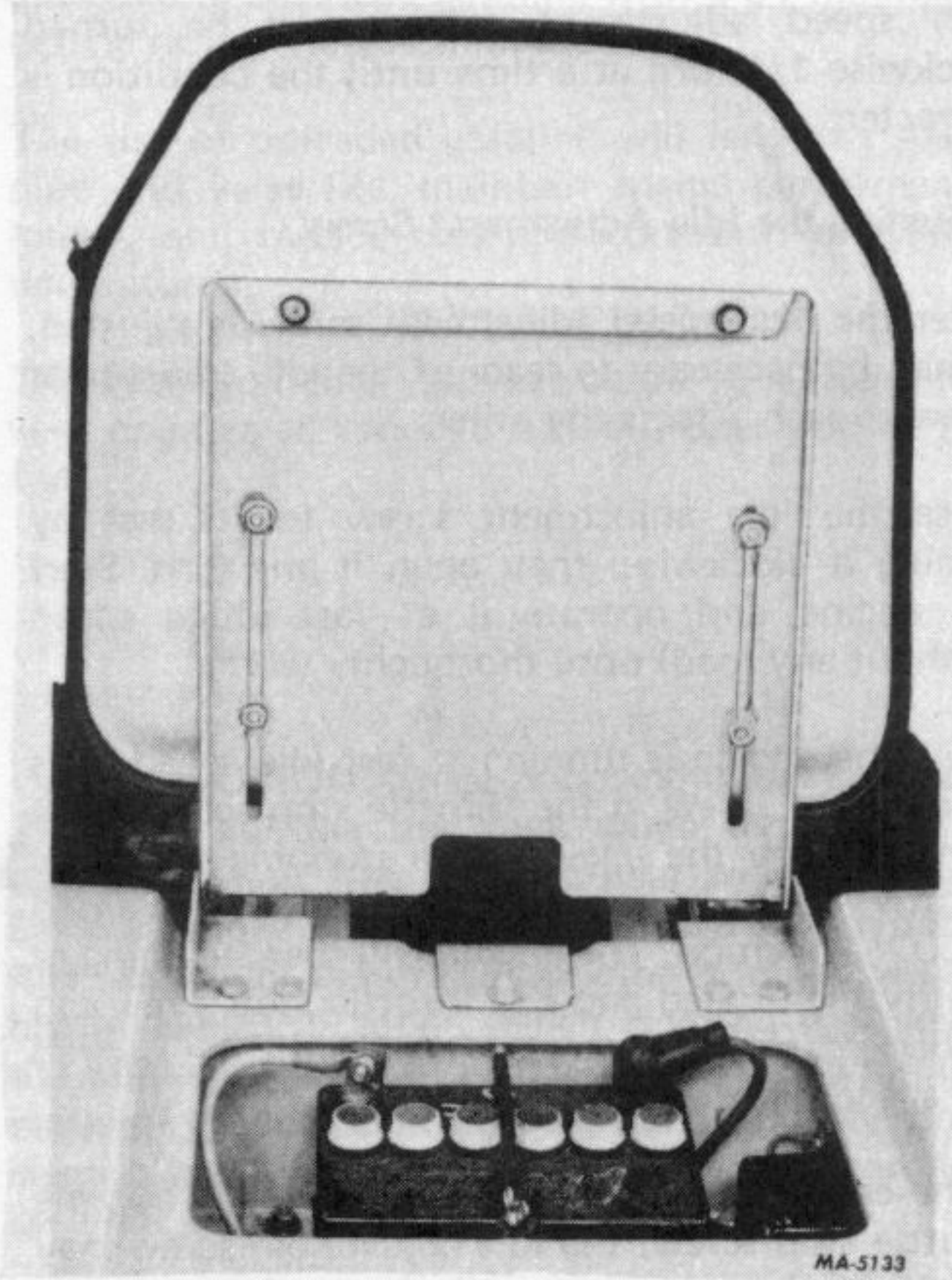

Adjusting the seat.

Retighten the cap screws after the seat is adjusted.

NOTE: The battery is located in a well under the operator's seat for ease in servicing or replacement when necessary.

CLUTCH AND BRAKE PEDAL

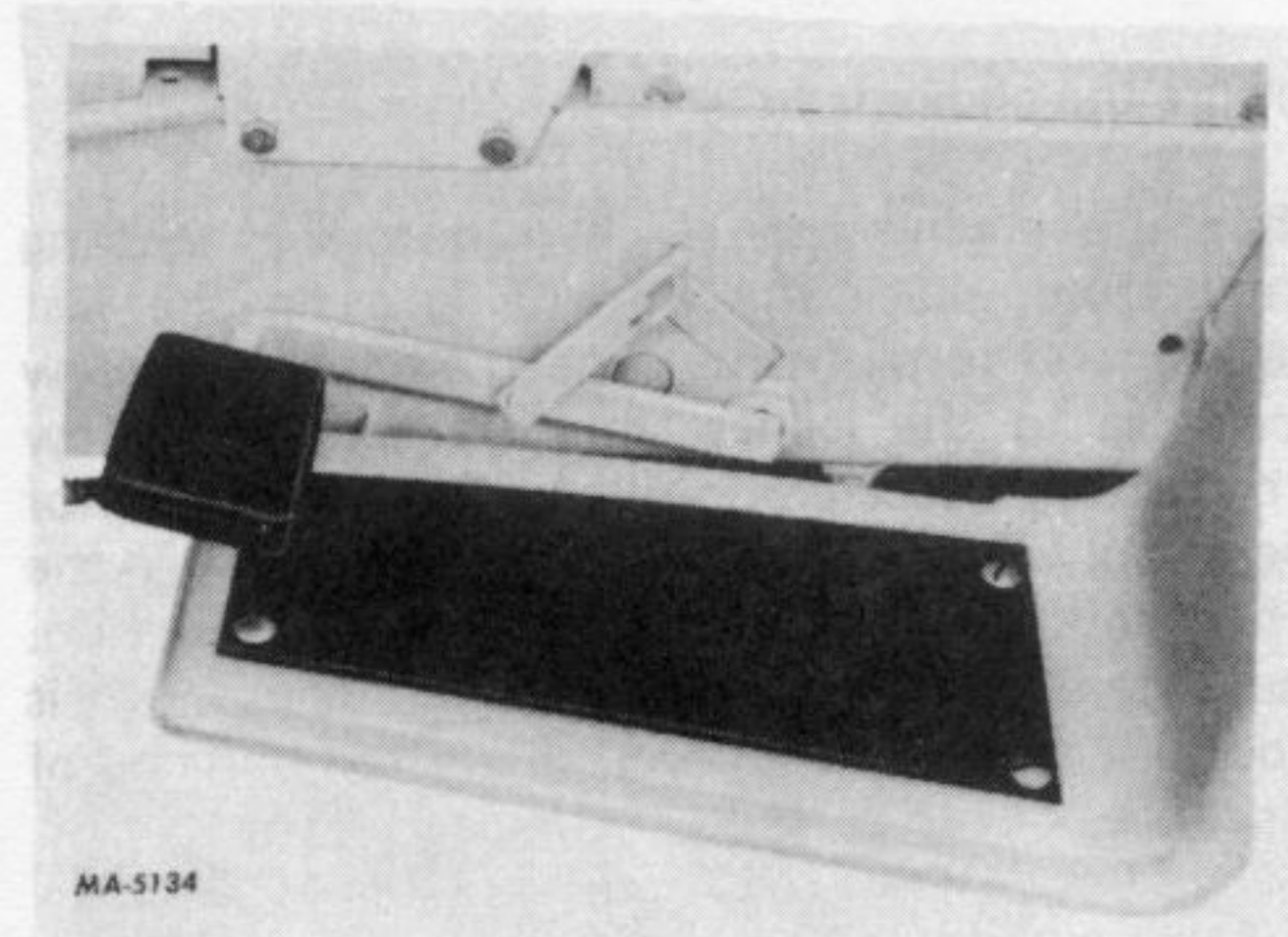

Brake pedal lock in the engaged position.

FUEL SHUT-OFF VALVE

Before starting the tractor, adjust the seat to the most comfortable driving position. Tilt the seat forward over the steering wheel, loosen the four cap screws in the seat support, and slide the seat assembly forward or rearward to the position which is most comfortable for the operator.

LOCKING THE BRAKE

Always lock the brake when the tractor is parked on a grade. To lock the brake, press down on the pedal; then place the brake pedal lock in the engaged position. To disengage the lock, press down on the pedal, lift the lock up and place it in the disengaged position.

International Cub Cadet 108, 126, 129,
149, and 169 Tractors.

DRIVING THE TRACTOR

International Cub Cadet 128, 148, and 168 Tractors

International Cub Cadet 86, 108 and 128 Tractors

CLUTCH-BRAKE PEDAL

The combination clutch-brake pedal is used to disengage the engine from the transmission when shifting gears and to actuate the brake to stop the tractor. The pedal must be pressed all the way down to activate the safety starting switch when starting the engine.

To disengage the clutch, and apply the brake, press the pedal all the way down.

GEARSHIFT LEVER

This lever is used to select various gear ratios provided in the transmission. There are three forward speeds and one reverse speed. Refer to "SPECIFICATIONS" on page 42.

STARTING THE TRACTOR

1. Advance the throttle lever slightly.
2. Disengage the clutch by pressing the clutch pedal all the way down, and release the brake lock. Move the gearshift lever to the desired speed.
3. Start the tractor in motion by **slowly** releasing the clutch pedal and moving the throttle lever to the position where the engine operates best for the load to be handled.

NOTE: When using power take-off operated equipment, best performance is achieved with the throttle lever in the "Fast" position.

NOTE: Do not shift gears while the engine clutch is engaged or while the tractor is in motion.

NOTE: Do not rest your foot on the pedal while driving the tractor, as this will result in excessive clutch lining wear.

Always be sure the rear wheels are free to turn. Under any adverse conditions, do not attempt to

free the tractor by speeding up the engine and suddenly engaging the clutch. Try backing out instead of going forward.



CAUTION! Do not carry passengers or give rides. Keep children, pets, and bystanders a safe distance away.

STOPPING THE TRACTOR

Disengage the clutch by pressing the pedal all the way down. Move the gearshift lever to the "N" position. Before dismounting always lock the pedal, disengage the power take-off, and turn the ignition "OFF".

CREEPER SHIFT LEVER

The creeper drive (optional) provides a slower speed in each respective gear, by a four-to-one reduction in speed from direct drive. When the creeper shift lever is all the way forward, it is in direct drive, or all the way rearward, it is in creeper drive.

OPERATING THE CREEPER DRIVE

To operate the tractor in creeper drive, depress the pedal and move the creeper shift lever all the way rearward. Then select the transmission speed desired and proceed as instructed under "Starting the Tractor".

NOTE: Do not use a mid-point position on the creeper drive as neutral. Neutral position must be selected only with the standard transmission gearshift lever.

The following table shows the speeds available in each of the three forward gears and the reverse gear.

DRIVING THE TRACTOR

International Cadet 86, 108 and 128 Tractors

OPERATING THE CREEPER DRIVE

SPEED TABLE

Gear	Miles Per Hour	
	Direct Drive	Creeper Drive
First	2.3	.6
Second	3.5	1.0
Third	6.8	1.7
Reverse	2.5	.6

DRIVING THE TRACTOR

International Cub Cadet 129, 149, and 169 Tractors

BRAKE PEDAL

The brake pedal must be pressed all the way down to activate the safety starting switch. When the brake pedal is in the depressed position it automatically moves the speed control lever to the "N" position.

The tractor can be stopped either by pressing the pedal all the way down, or placing the speed control lever in the "N" position.

SPEED CONTROL LEVER

This lever is used to select any speed from a standstill "N" position to eight miles per hour in the forward direction and to four miles per hour in the reverse direction.

Moving the speed control lever forward provides increased forward speed, and moving the lever rearward provides the reverse speeds.

NOTE: Do not rest your foot on the brake pedal while driving the tractor as this would cause the speed control lever to return to the "N" position.

NOTE: On tractors with a rotary tiller the following instructions are required.

1. Engage the Power Take-Off clutch, and move the throttle to "Fast".
2. Lower the rotary tiller to the desired cutting depth.
3. Move the speed control lever to start forward motion. **NOTE:** In rotary tilling application, the tractor is used to hold the rotary tiller back rather than to pull the unit as in plowing or mowing.
4. Move the speed control lever back to a position to maintain proper mulching of the soil.
5. With a hydrostatic drive, it may be necessary to vary the speed control lever as the soil conditions vary. With a gear driven tractor, under similar conditions it may be necessary to declutch or to use the brake.

DRIVING THE TRACTOR

International Cub Cadet 129, 149, and 169 Tractors

STARTING THE TRACTOR

1. Depress the brake pedal and release the brake lock. Move the throttle lever to the position where the engine operates best for the load to be handled.
2. Start the tractor in motion by moving the speed control lever slowly forward or rearward as described above.

RELEASE LEVER

To push or move the tractor for a short distance, the release lever must be held in the (up) position and the speed control lever must be in the "N" position.



CAUTION! Never operate engine with release lever in (up) position. Towing or pushing the tractor for more than a few feet may result in transmission damage.

STOPPING THE TRACTOR

Move the speed control lever to the "N" position or use the brake. Before dismounting always lock the brake pedal and turn the ignition "OFF". Also, disengage the power take-off clutch lever.



CAUTION! Do not carry passengers or give rides. Keep children, pets, and bystanders a safe distance away.

EQUIPMENT LIFT HANDLE

The lift handle is used to lift or lower equipment used with the tractor. The equipment can be set in multiple positions by depressing the button on the top of the handle and releasing it when the desired position is reached.

HEIGHT ADJUSTMENT

If a single implement height is normally used, the handle may be adjusted to locate the desired position by use of the cam stop.

With lift handle in desired implement height position, release cam by turning locking knob counter-clockwise. Turn cam until it contacts tang. Lock cam into this position by turning knob clockwise.

If free handle travel between cam stop and fully raised position is desired (Float Position), depress the release button on top of the handle, press in the lock button located at the front of the handle and release the top button.

NOTE: To disengage the lift handle from the float position, pull lift handle back slightly and depress top button.

NOTE: Refer to the equipment manual for proper hitching instructions.

HITCHING EQUIPMENT TO THE TRACTOR

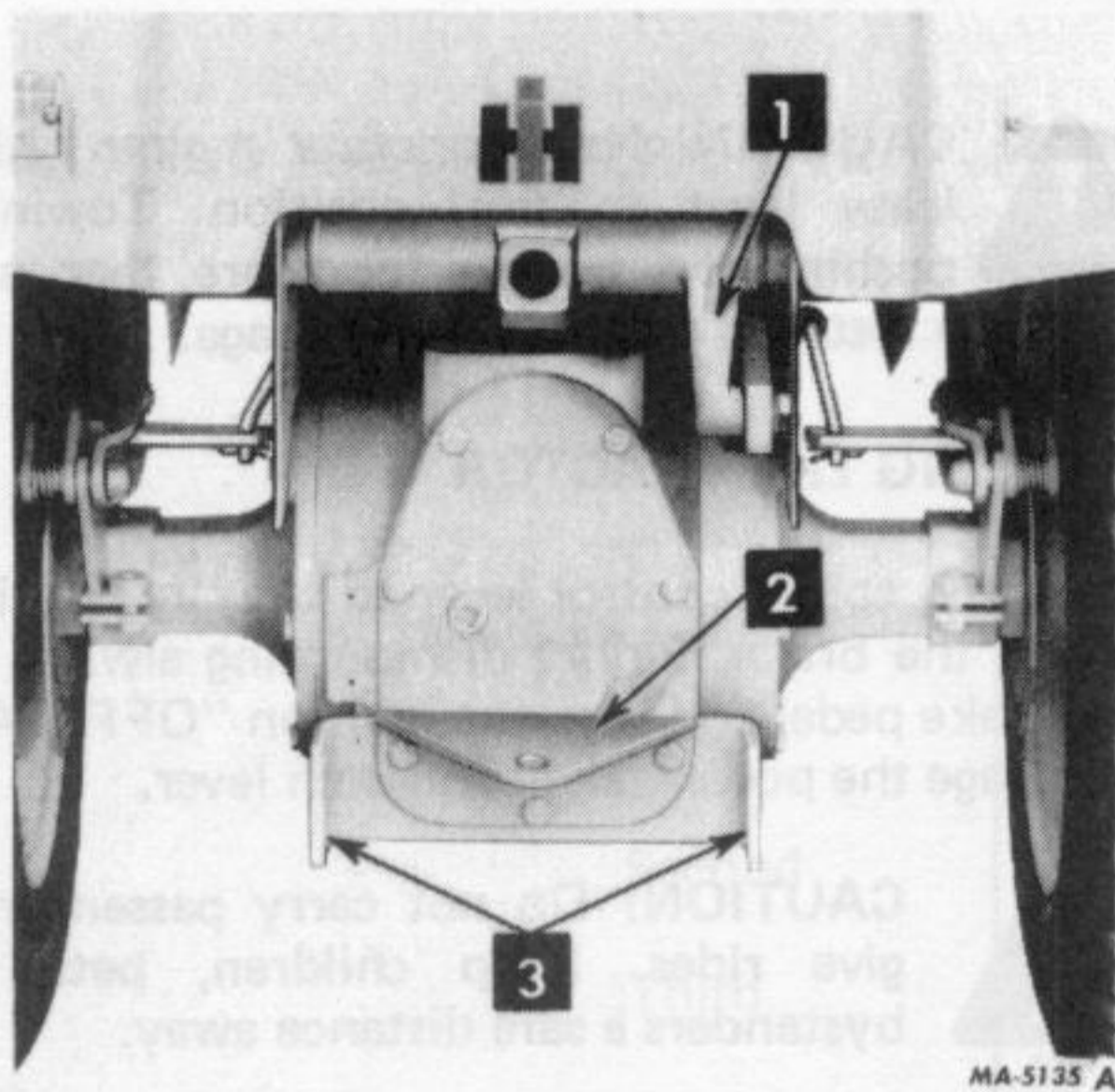

- 1. Lift lever
- 2. Draw bar
- 3. Three-point hitch

Drawbar and three-point hitch shown on International Cub Cadet 86 Tractor.

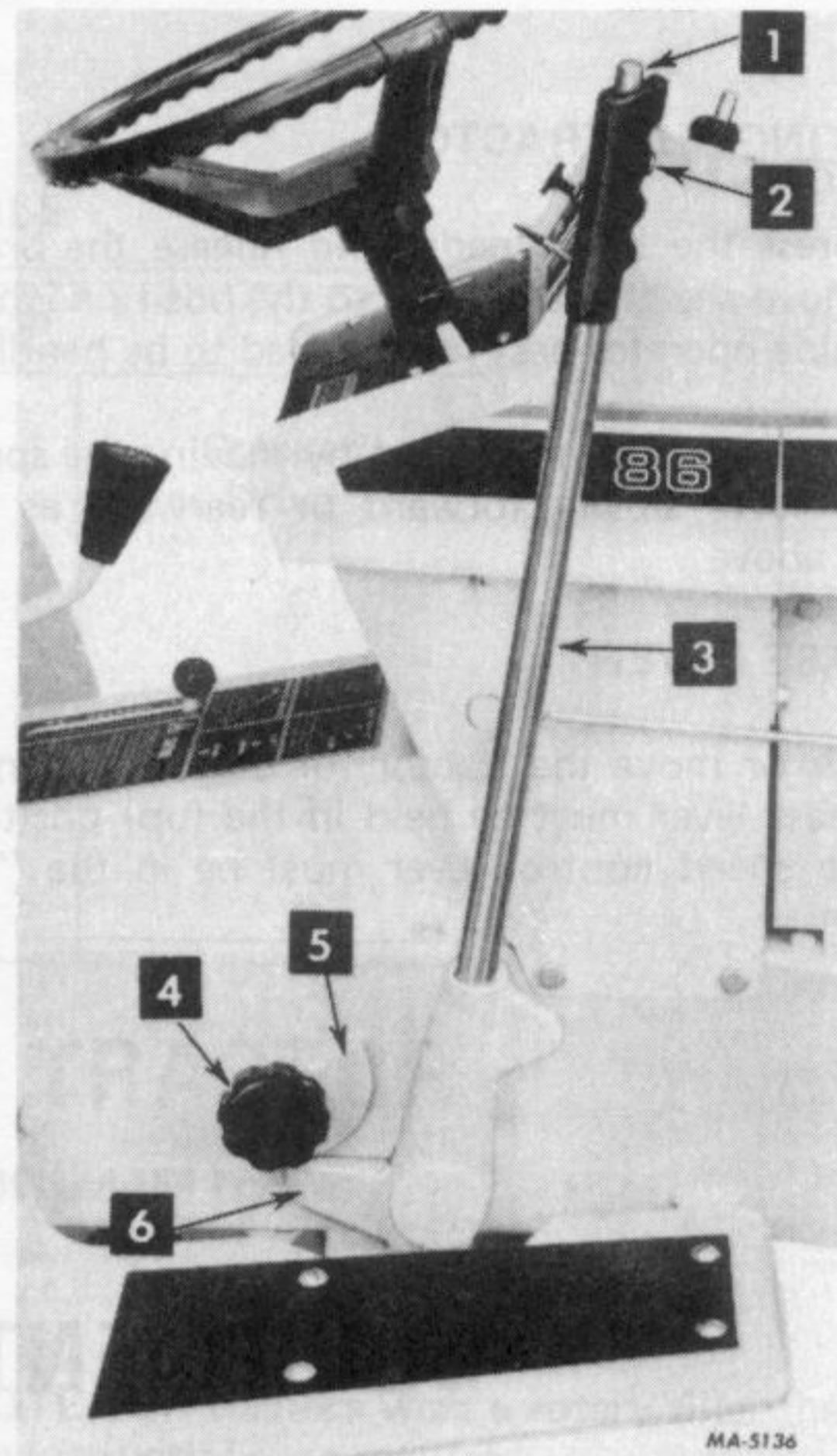

- 1. Release button
- 2. Lock button
- 3. Lift handle
- 4. Cam lock knob
- 5. Cam stop
- 6. Tang

Adjustable stop limiting handle travel.



CAUTION! Disengage power to any attachment when transporting or not in use.

NOTE: Refer to the equipment manual for proper hitching instructions.

DRAWBAR

Drawbar equipment must be hitched to the tractor only at the hitch hole in the drawbar.

THREE-POINT HITCH

When the tractor has a three-point hitch, equipment adaptable to this hitch is raised and lowered with the lift handle or power lift control. The lift handle can be set to hold the equipment at various positions by use of the notches in the lift handle quadrant or cam stop. The lower mounting bracket has three holes which are used for additional adjustment.

REAR POWER TAKE-OFF

International Cub Cadet 86, 108 and 128 Tractors

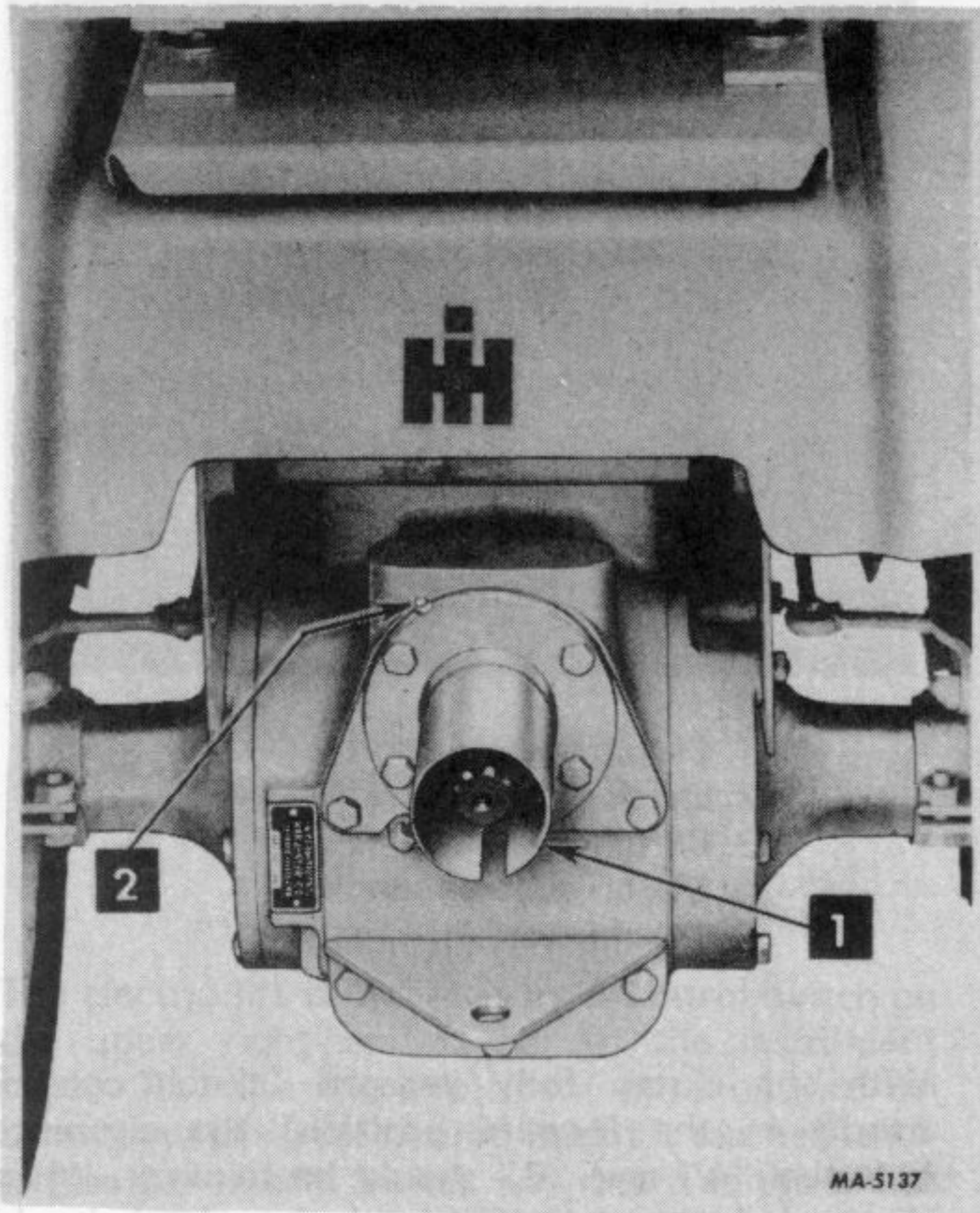

1. Power take-off guard
2. Grease fitting

If your tractor is equipped with a rear power take-off, the following instructions should be carefully studied and followed.

The rear power take-off is started and stopped by the same engine clutch as the tractor. Be sure to disengage the engine clutch before moving the power take-off shifter lever.

CAUTION! The shifter lever should always be in the disengaged (rearward) position when the power take-off is not in use. Always cover the power take-off exposed shaft with the guard when the power take-off is not being used.



1. Shifter lever

OPERATING THE REAR POWER TAKE-OFF WITH THE TRACTOR STANDING STILL

1. Move the throttle lever back to the "SLOW" speed.
2. Depress the pedal and move the transmission gearshift lever to the neutral position.
3. Move the shifter lever forward to the engaged position.
4. Move the throttle lever forward to the "FAST" position and slowly release the pedal.

OPERATING THE REAR POWER TAKE-OFF WITH TRACTOR IN MOTION

Follow steps 1 thru 3 outlined above. Keep the pedal depressed, move the transmission gearshift lever to the speed desired and advance the throttle lever. Slowly release the clutch pedal. This will start the tractor in motion with the power take-off in operation.

FRONT POWER TAKE-OFF

OPERATING THE FRONT POWER TAKE-OFF CLUTCH

1. Move the throttle lever back to the medium or "slow" position.
2. Move the control lever forward slowly to the engaged position.
3. Advance throttle to operating speed.

ADJUSTING THE POWER TAKE-OFF CLUTCH

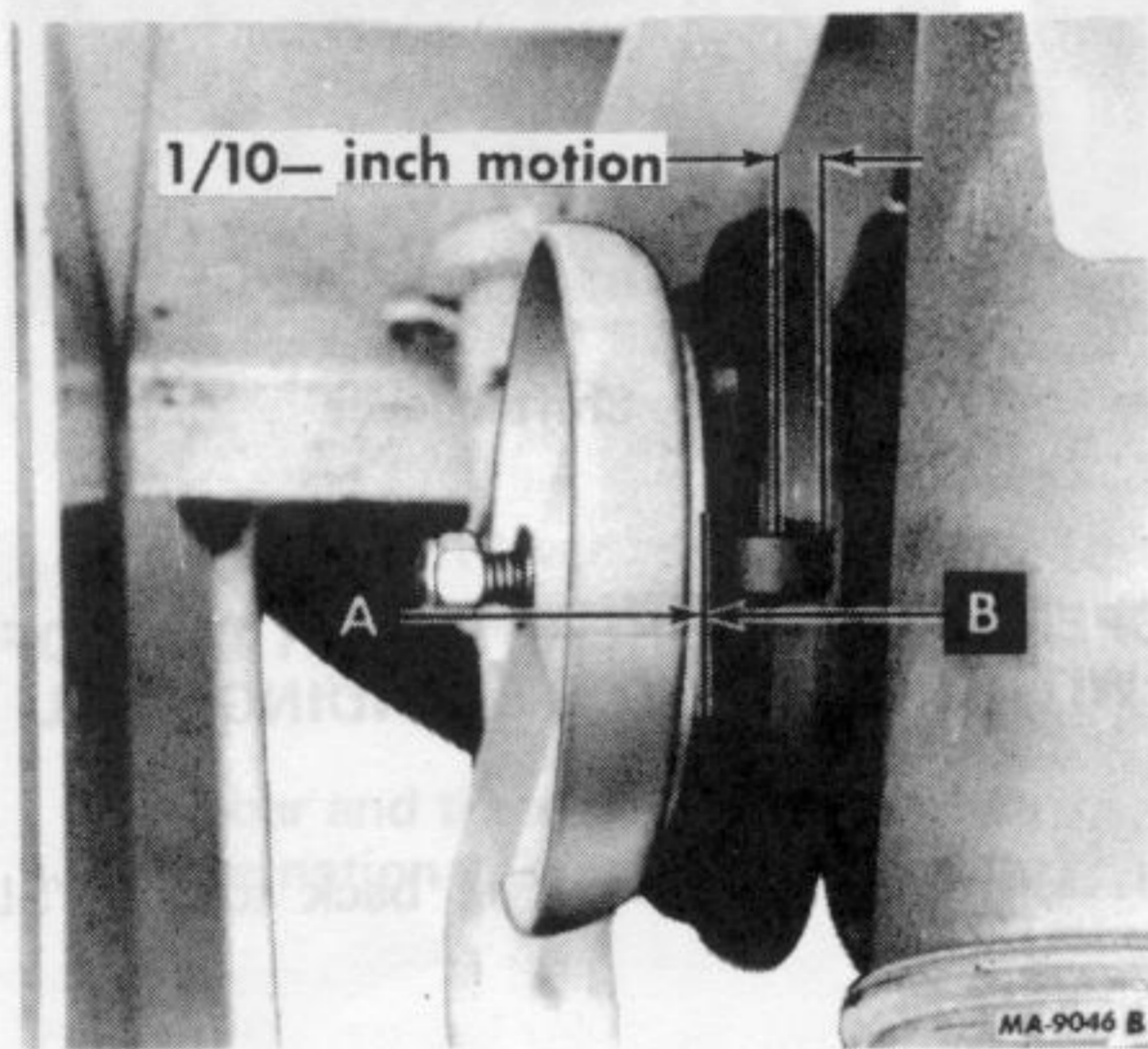

The clutch is factory adjusted and should not require further adjustment under normal operating conditions. However, if clutch slips or fails to disengage, see your International Harvester dealer.

After considerable use, it may be necessary to readjust the clutch to secure proper clutch engagement.



CAUTION! Do not adjust with engine running.

ELECTRIC LIFT

The electric lift is a self-contained unit designed to provide power with fingertip control for raising the lowering mounted equipment.

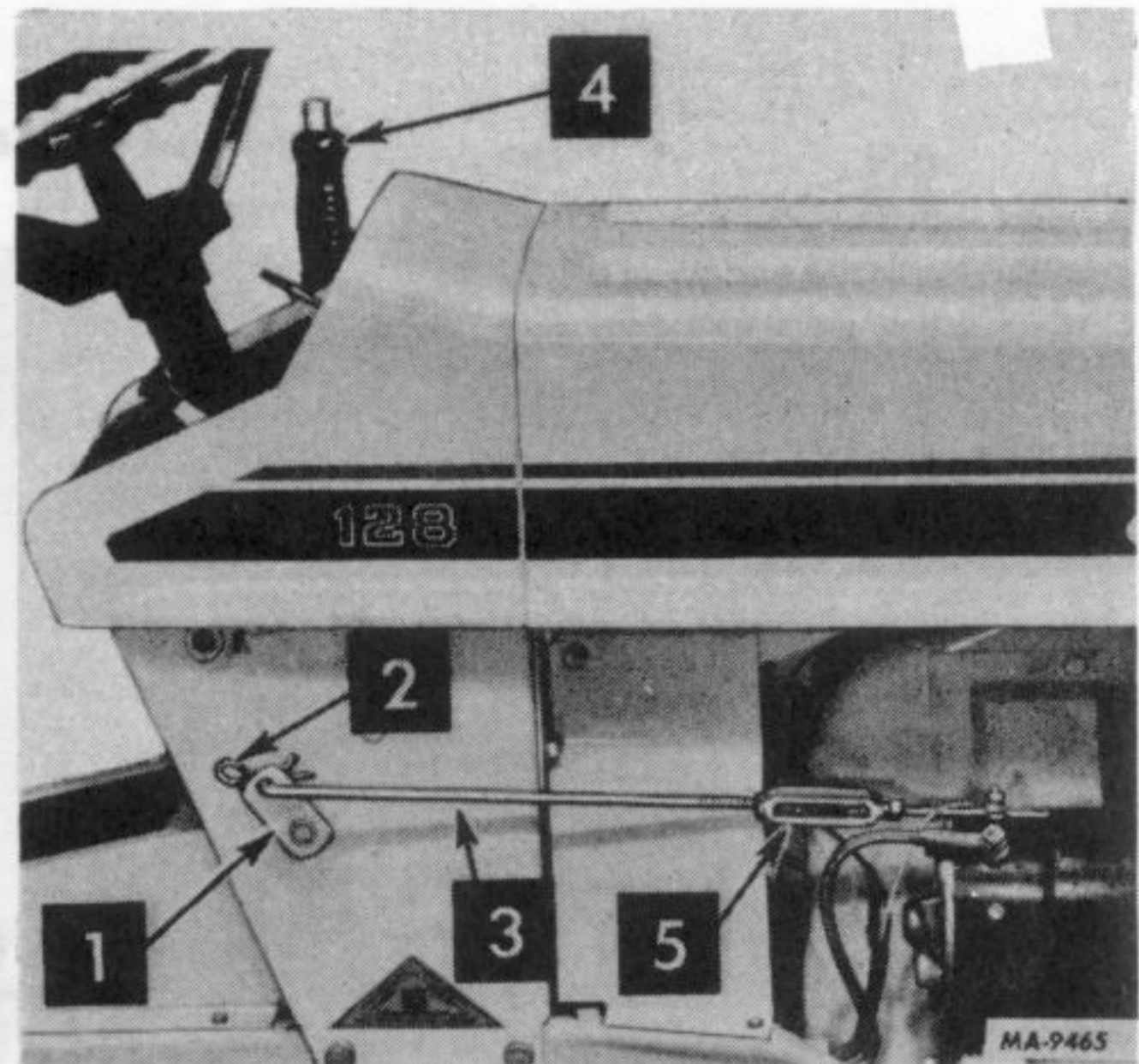

1. Clutch lever bracket
2. Quick attachable cotter pin
3. Clutch lever rod
4. Clutch control handle
5. Turnbuckle

With the clutch fully engaged (clutch control handle in the forward position) the clearance between "A" and "B" should be minimal. When disengaged, the plate "B" (with three legs) should move a minimum of 1/10 inch to insure disengagement. To adjust for proper clearance, loosen the jam nut on the clutch lever turnbuckle, and adjust the turnbuckle. After obtaining the proper clearance tighten the jam nut securely against the turnbuckle.

NOTE: Periodically lubricate the bushing in the clutch lever bracket with a few drops of engine oil.

The electric lift is available on all Cub Cadet Tractors except the Models 149 and 169 which is equipped with a hydraulic lift as standard.

ENGINE COOLING AND AIR CLEANER

ELECTRIC LIFT

ENGINE COOLING

OPERATING INSTRUCTIONS

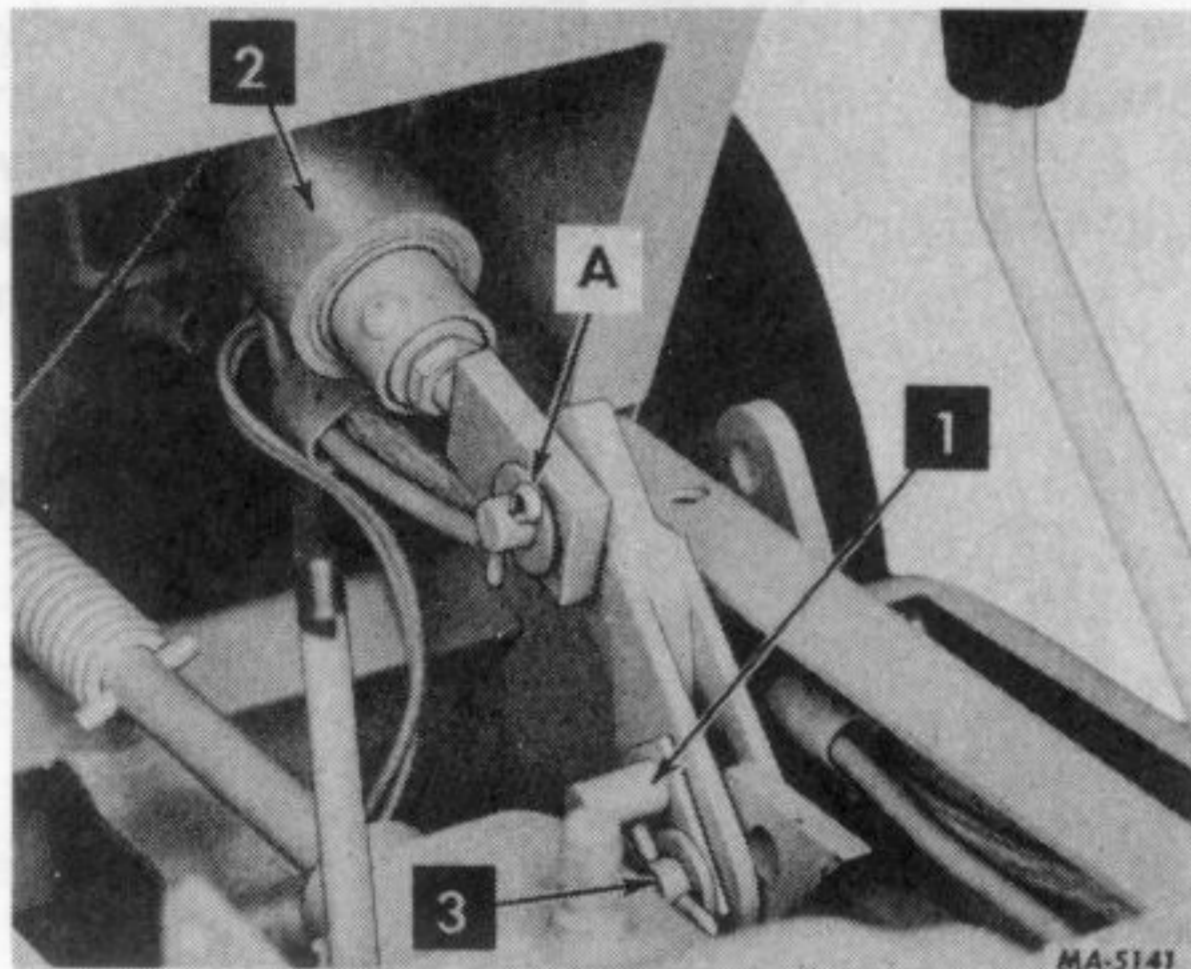

1. Float lockout pin (optional)
2. Electric lift unit
3. Pivot pin

The electric lift is operated by a control switch on the upper right-hand corner of the instrument panel. To raise the implement push upward on control switch until desired height is reached, then release the switch. Switch will return to the center or neutral position. Equipment will stay in a given position when you release the switch. To lower equipment push down on the control switch. Switch will again return to the central or neutral position when you release it.

NOTE: Always operate electric lift with tractor engine running. Operation of electric lift off the battery will cause premature battery failure.

NOTE: Whenever raising or lowering equipment release control switch when equipment has reached a fully raised or lower position. Holding control switch will cause protective switch to open the circuit. Lift will function after waiting 30 seconds.

Equipment is normally operated in a "Float" position (implement free to move upward) with lock pin (optional) positioned as shown. Cam stop on the outside of the frame may be adjusted as

Incoming air for combustion is filtered by a dry-type air cleaner having a filter element inside

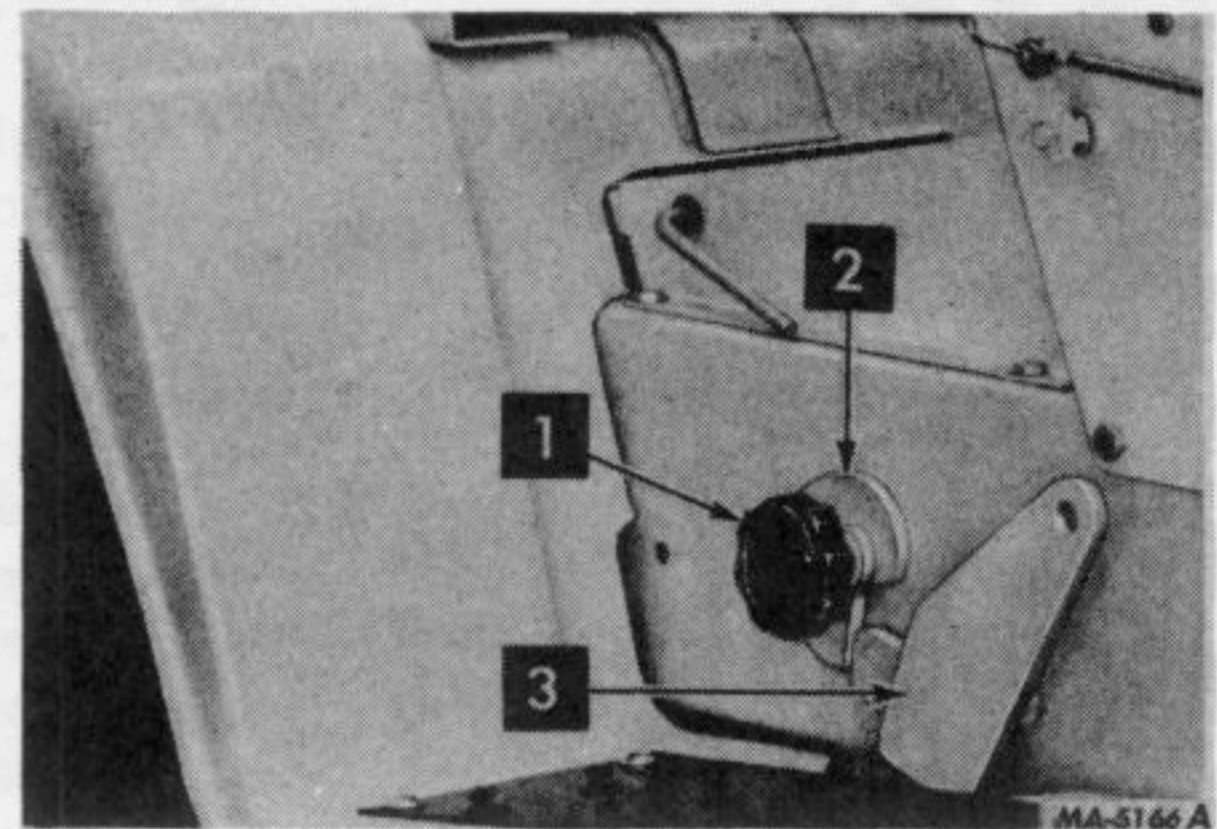

1. Locking knob
2. Cam stop
3. Rockshaft arm

described on page 15 to allow implement to return to a single preset height.

To operate equipment in a fixed "Locked" position, where down pressure of implement is required (that is blade work); remove frame cover and remove cotter pin in pivot. Reverse lock pin (optional) and insert into pre-aligned holes in clevis and lower portion of rockshaft arm. Replace washer and cotter pin.



CAUTION! Always stop the engine and set the brake pedal in the locked position before making any adjustments to the machine.

NOTE: Remove or position cam stop on side of frame for full travel of rockshaft before locking rockshaft arms as described above.

NOTE: To avoid possible damage, as soon as the operation requiring "Down Pressure" is completed, immediately return the float lockout pin to the "Free to Float" position.

Refer to equipment manual for proper mounting instructions.

NOTE: Periodically lubricate pin "A" with a few drops of engine oil.

HYDRAULIC LIFT-OFF

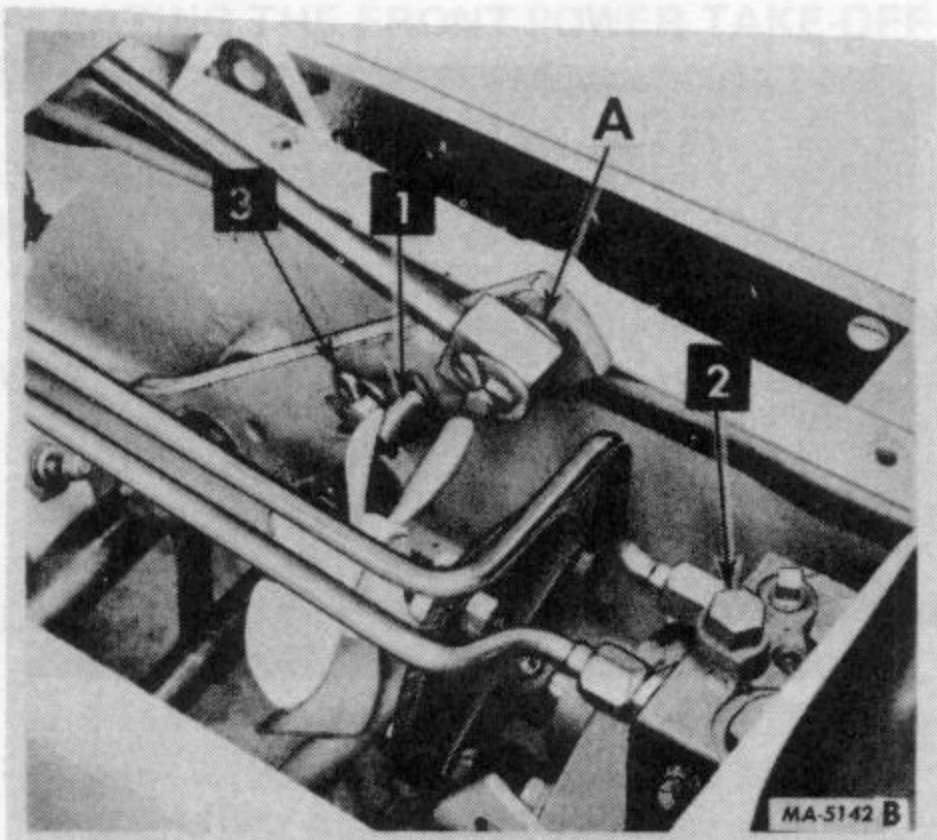

1. Float lockout pin (optional)
2. Hydrostatic drive unit
3. Cotter pin

The hydraulic lift is ready to operate when the engine is running.

OPERATING INSTRUCTIONS

The hydraulic control lever is spring loaded. To raise the equipment move the lever back, toward the tractor seat. To lower the equipment move the lever forward, as shown.

Equipment is normally operated in a "Float" position (implement free to move upward) with the lock pin (optional) positioned as shown.

The cam stop may be adjusted as described on page 15 to allow the implement to return to a single preset height.

To operate equipment in a fixed "Locked" position, where down pressure of the implement is required (that is blade work), remove frame cover and remove cotter pin in pivot pin. Reverse lock pin (optional) and insert into pre-aligned holes in clevis and lower portion of rockshaft arm. Replace washer and cotter pin.

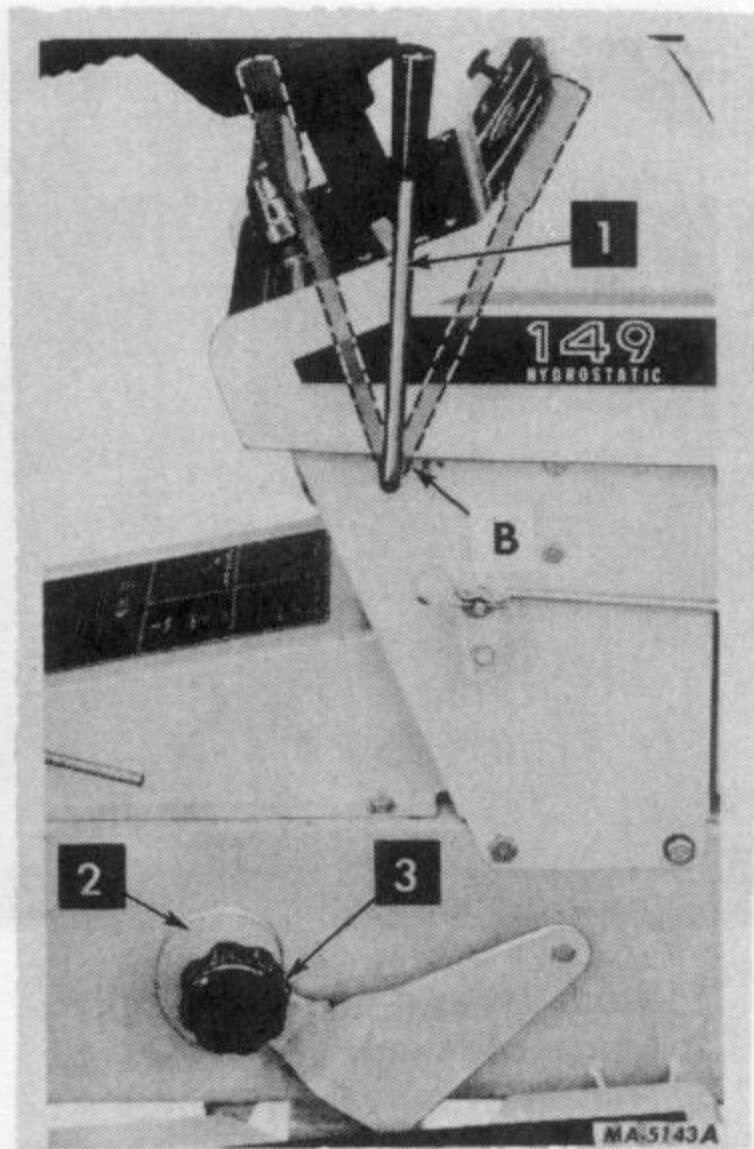

1. Hydraulic lift handle
2. Cam stop
3. Locking knob

NOTE: Remove or position cam stop on side of frame for full travel of rockshaft before locking rockshaft arm as previously described.

NOTE: To avoid possible damage, as soon as the operation requiring "Down Pressure" is completed, immediately return the float lockout pin to the "Free to Float" position.

Refer to equipment manual for proper mounting instructions.

NOTE: Periodically lubricate pin "A" and bushing "B" with a few drops of engine oil in both locations.

ENGINE COOLING AND AIR CLEANER

ENGINE COOLING

This tractor has an air cooled engine. Air must be able to circulate freely around the engine, through the screen, shroud, and over the fins of the cylinder head and cylinder block. Keep these areas free of accumulated dirt and trash or engine will overheat and result in damaged moving parts. Periodic cleaning with compressed air will keep area clear for adequate cooling.

DRY TYPE AIR CLEANER

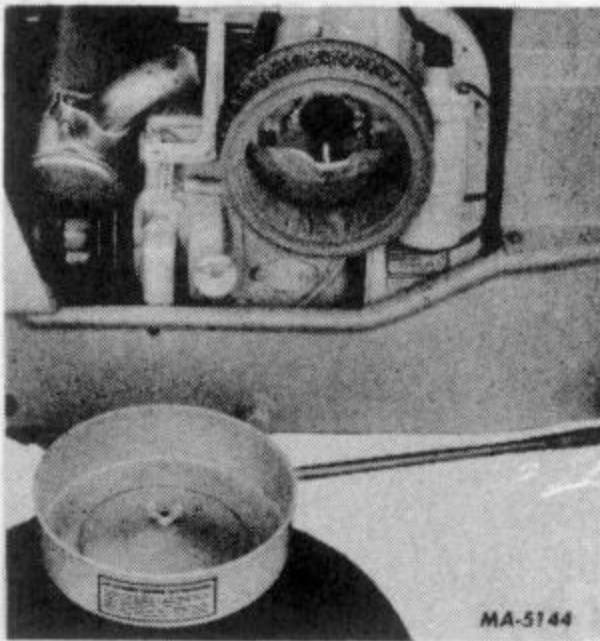

Removing the air cleaner filter element.

Incoming air for combustion is filtered by a dry-type air cleaner having a filter element inside of the cover.

Clean or replace the element when loss of power is noticeable. Replace at least once a year.

Cleaning the Element — To clean the element, remove wing nut, air cleaner cover, then remove element and tap it lightly on a flat surface to cause loose dirt to fall off. Handle paper element with care to avoid dents or crushing local areas. Do not use compressed air to remove dirt as this can reapture the element. Do not wash or use a solvent.

Replacing the Element — Replace element with a new one if dirt does not drop off easily, or if it is bent or damaged. When replacing element be sure the back plate is securely tightened to the carburetor. Replace the back plate if bent or cracked, then be sure the element fits snugly around the inside edge of the air cleaner base. The gasket surfaces of the element must be flat against the back plate and cover to seal effectively. Replace cover and tighten wing nut finger tight.

ELECTRICAL SYSTEM

The twelve-volt electrical system consists principally of a motor-generator, voltage regulator, and a twelve-volt battery.

All connections must be clean and securely fastened.

IGNITION SWITCH

Turn the key clockwise to turn on the ignition. A further turn actuates the motor-generator. The key cannot be removed when in the "ON" position.

NOTE: When the engine is not operating, the key must be turned to the "OFF" position to prevent battery discharge.

SAFETY STARTING SWITCH

The safety starting switches activated by the clutch-brake pedal and the power take-off clutch lever serve to prevent starting the engine accidentally.

ELECTRICAL SYSTEM

CHARGE INDICATOR

This instrument indicates whether the motor-generator is charging or the battery is discharging. If it shows discharge continuously, investigate the cause to avoid completely discharging the battery and possible damage to the motor-generator.

HOUR METER

The International Cub Cadet 169 is equipped with an hour meter, which is located on the left side of the tractor parallel to the air cleaner. It indicates the actual hours of engine operation, enabling the operator to determine without guesswork, when lubrication, change of oil, or periodic inspections are necessary. It also provides a means of computing cost of specific jobs. The hour meter operates whenever the engine is running.

SPARK PLUG

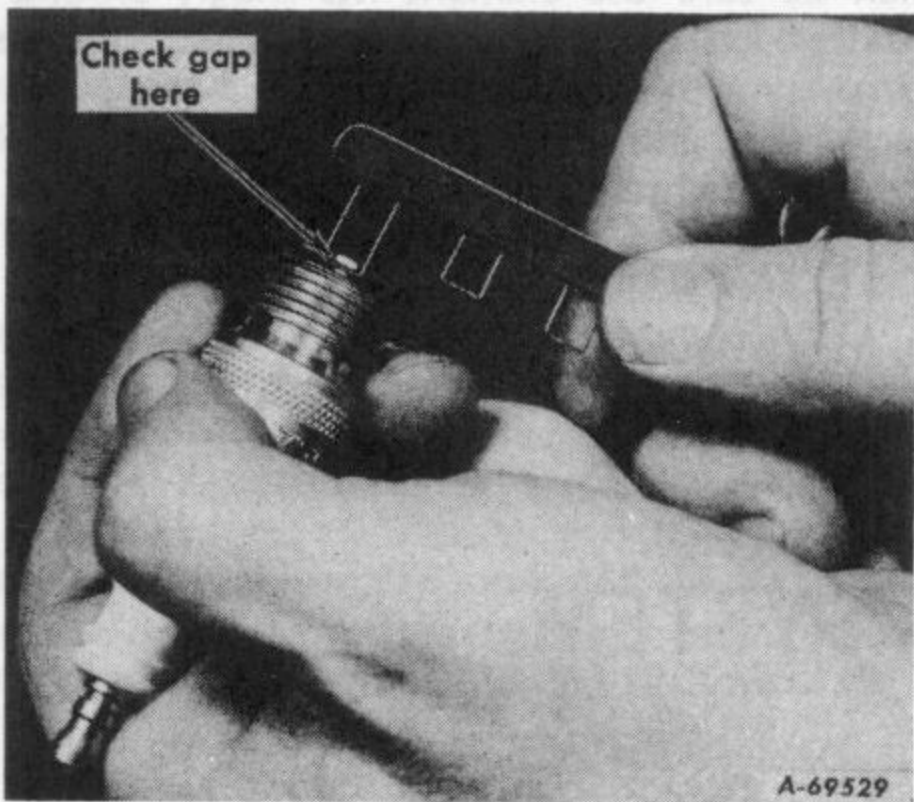

Checking the spark plug gap.
Set gap at .025-inch.

NOTE: Remove all dirt from around the spark plug before removing.

Remove the spark plug, always using a spark plug wrench, after every 100 hours of operation to check the gap.



CAUTION! Be sure engine is off and cool before making any adjustments or repairs.

Be sure the gasket is in good condition. Tighten the plug 1/2 to 3/4 turns past finger tight.

Replace a defective plug with a new plug. See your International Harvester dealer for the correct replacement plug.

MOTOR GENERATOR

The motor-generator (12-volt negative ground) will function as a cranking motor when the ignition key is turned to the "START" position, driving the engine by means of a belt.

When the engine is operating, the unit will function as a generator.

MOTOR-GENERATOR BELT

Check the tension of the motor-generator belt after the first 10 hours of operation and every 50 hours of operation thereafter. The tension is correct when the belt can be deflected a maximum of 1/4-inch by a ten pound force applied midway between the two pulleys.



CAUTION! Check the belt with engine off.

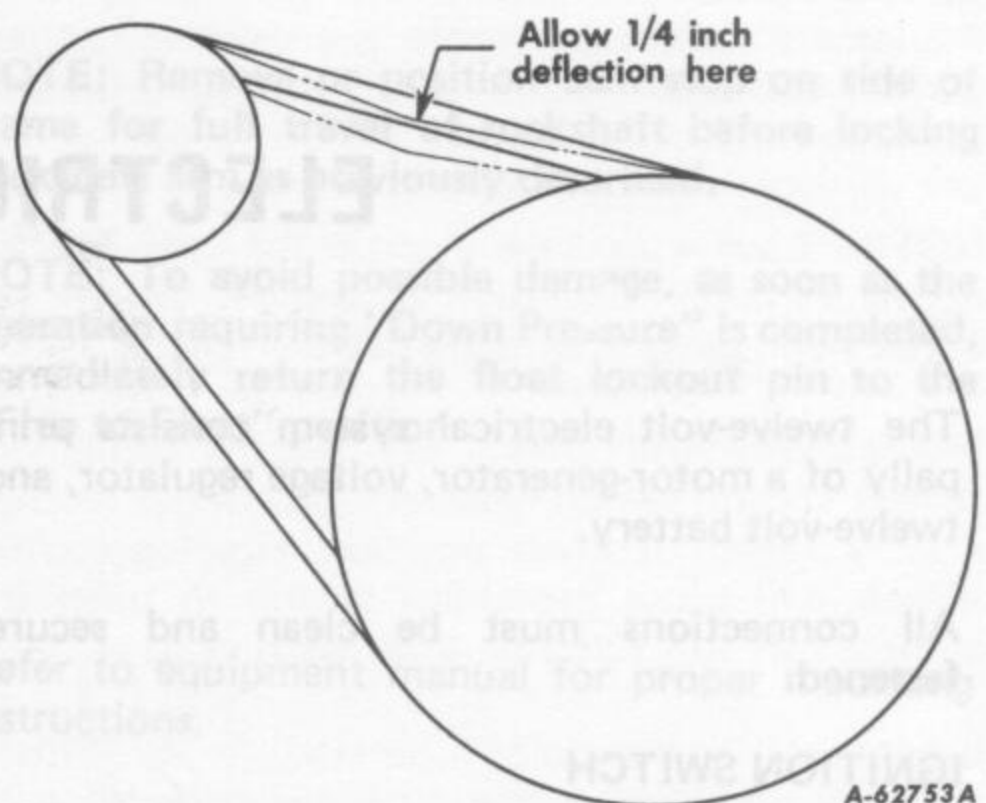

Correct motor-generator belt tension.

Also follow this procedure when a new belt is installed.

ELECTRICAL SYSTEM

MOTOR-GENERATOR BELT — Continued

Adjusting the Motor-Generator Belt

Loosen the motor-generator brace bolt and mounting bolts.

Move the generator away from the engine until the tension on the belt is correct.

NOTE: Under no circumstances should a pry bar be used on the motor-generator to obtain belt tension as damage to the bearings will result.

Tighten mounting bolts and brace bolt.

Removing and Replacing the Motor-Generator Belt

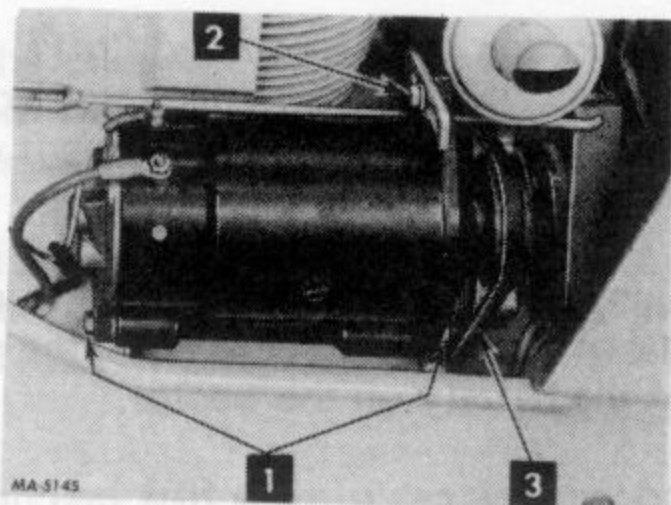

1. Mounting bolts
2. Motor generator brace bolt
3. Motor generator belt

Replace the motor-generator belt when it becomes badly worn. To remove the old belt, loosen the motor-generator brace bolt and mounting bolts. Move the generator in toward the engine and slip the old belt off the pulleys and over the crankshaft. Install the new belt in the reverse order of removal and adjust the belt to the proper tension.

NOTE: If tractor is equipped with rotary mower, drive belt must also be removed when replacing generator belt.

VOLTAGE REGULATOR

A satisfactory generator charging rate is maintained by the voltage regulator. If the regulator fails to operate correctly, see your International Harvester dealer.

NOTE: Never place a jumper lead between, or accidentally bridge, the "BAT" terminal and the "F" terminal on the regulator, as this will damage the regulator.

LIGHTS

Lights are optional on all models except the Models 149 and 169.

The headlights are sealed-beam units. Refer to "SPECIFICATIONS" when replacement is necessary.

To replace the taillight lamp, remove the lens from the taillight and replace. Refer to "SPECIFICATIONS".

FUSE (Electric Lighting)

Always use the same capacity fuse for replacement. Refer to "Specifications". If the lights fail, check the fuse.

The fuse is located in a fuse housing in the line at the back of the instrument panel.

To install a new fuse, press in on the fuse housing cap and turn counterclockwise to remove it from the fuse housing. Remove the old fuse and replace it with a new one. Then reassemble the cap to the housing. Remove the fuel tank if necessary to reach the fuse.

Before working on any part of the electrical system, disconnect the battery ground cable at the battery negative (-) terminal. Do not reconnect this cable until all work has been completed. This will prevent shorting and damage to any of the electrical units. Examine the electrical cables occasionally to be sure they are not being frayed by contact with adjacent parts.

ELECTRICAL SYSTEM

When replacing a battery, make certain the ground cable is connected to the negative (-) terminal on the battery. Be sure the rubber boot is properly positioned over the positive (+) terminal on the battery. **NOTE:** Both cables must be assembled with the nuts to the inside of the terminals to prevent shorting against fender well.

Cleaning and Servicing the Battery

Occasionally remove the battery cables and brighten the terminal contact surfaces with wire wool, and reassemble them. Apply a light coat of vaseline or chassis lubricant. Be sure the terminals are clamped tightly and that the battery is fastened securely in the battery box. Replace unserviceable cable. Keep the vent holes in the battery filler caps open.

Keeping the battery fully charged not only adds to its life but makes it available for instant use when needed.

Liquid Level

Check the battery at least once a month for water level.

The electrolyte (acid and water) in each cell should be at ring level at all times to prevent battery failure. When the electrolyte is below this level, add pure, distilled water.

Acid or electrolyte should never be added except by a skilled battery man. Under no circumstances add any special battery "dopes", solutions or powders.



CAUTION! If the rider is to be tipped up or on its side remove the batteries to avoid spilling the electrolyte. Battery electrolyte is poisonous and can be injurious to eyes, skin, and clothing. If electrolyte is spilled, flush immediately with a solution of one part baking soda to four parts water.

Connecting Booster Batteries

When required, a booster 12-volt battery may be connected in parallel with the 12-volt system on International Cub Cadet Tractors.



CAUTION! Gas discharged by batteries is explosive. Avoid sparks near the batteries.

NOTE: All circuits must be turned "off". Electrical system is NEGATIVE (-) grounded only. Reversed polarity will result in permanent damage to components of the electrical system.

The first jumper cable must connect the positive (+) terminal of the booster battery and the positive terminal of the battery on the tractor.

The second jumper cable must first be connected to the negative (-) terminal of the booster battery; and then to a point on the frame of the tractor, away from the battery, having a good ground, so no spark occurs near the battery.

For dependable battery service, see your International Harvester dealer.

PNEUMATIC TIRES

REAR TIRES

6-12 rear tires are standard equipment on the International Cub Cadet 86 and 108 Tractors.

23 x 8.50-12 high floatation tires are standard equipment on the International Cub Cadet 128, 129, and 149 Tractors. They are also available as optional equipment when ordered for the International Cub Cadet 86 and 108 Tractors.

23 x 10.5-12 tires are standard on the International Cub Cadet 169 Tractor.

The high floatation tires provide maximum mobility in sand, snow, and soft soil conditions. The reduced ground pressure and low inflation provides maximum protection for turf, soil and crops.

PNEUMATIC TIRES

CARE OF TIRES

Avoid stumps, stones, deep ruts, curbs, and other hazards. Cuts in tires should be repaired immediately as neglect decreases the tire life.

Keep tires free from oil and grease as both destroy rubber.

After using the tractor for spraying use water to remove any chemicals that may be on the tires.

INFLATION

Keep the pneumatic tires properly inflated. Over-inflation will cause operator discomfort. Under-inflation will cause short tire life.

Always see that the tire valve caps are in place and tightened securely to prevent loss of air and protect the valve core and stem.

OPERATING PRESSURE FOR TIRES

Inflate the front and rear tires for normal or heavy load operations as shown in the following table.

Tire Size	Normal Load	Heavy Load
Front Tires	Pounds per square inch	
4.80/4.00-8	12	12
16 x 6.50-8	12	12
Rear Tires 6-12	12	12
23 x 8.50-12	12	12
23 x 10.50-12	12	12

MOUNTING TIRES ON THE RIM

After mounting a new or old tire on the rim, inflate it to 20 pounds pressure to seat the tire bead on the rim flange. Then deflate the tire to the correct operating pressure.

REAR WHEEL WEIGHTS

Rear wheel weights increase traction and reduce wheel slippage. The weights weight approximately 26 pounds each. They are attached to each rear wheel with two bolts, lock washers, and hex. nuts.

If additional weight is desired, a second set of weights can be attached to each first weight by using two longer bolts.

TIRE CHAINS

Tire chains will provide additional traction for wet ground conditions, when plowing snow, or pulling heavy loads. Rear wheel weights are recommended when using chains.

OVERLOADING

Do not overload the tractor tires by mounting equipment on the tractor which exceed the load capacity of the size of the tires on the tractor.

FRONT WHEELS

FRONT QUICK ATTACHING LATCH

This latch is used for front and center mounted equipment. Refer to the equipment manual for proper instructions.

FRONT WHEEL TOE-IN

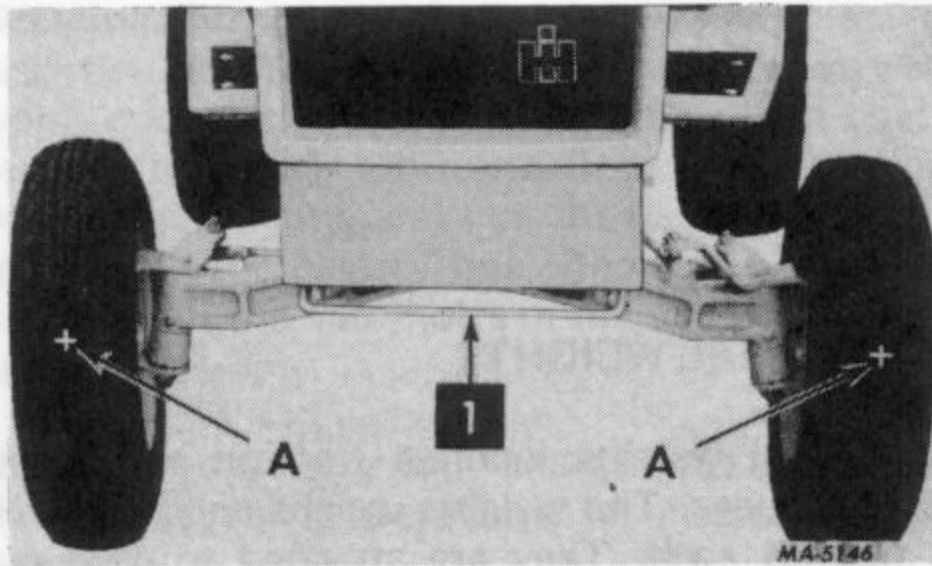

1. Front quick attaching latch

Front wheel adjustments.

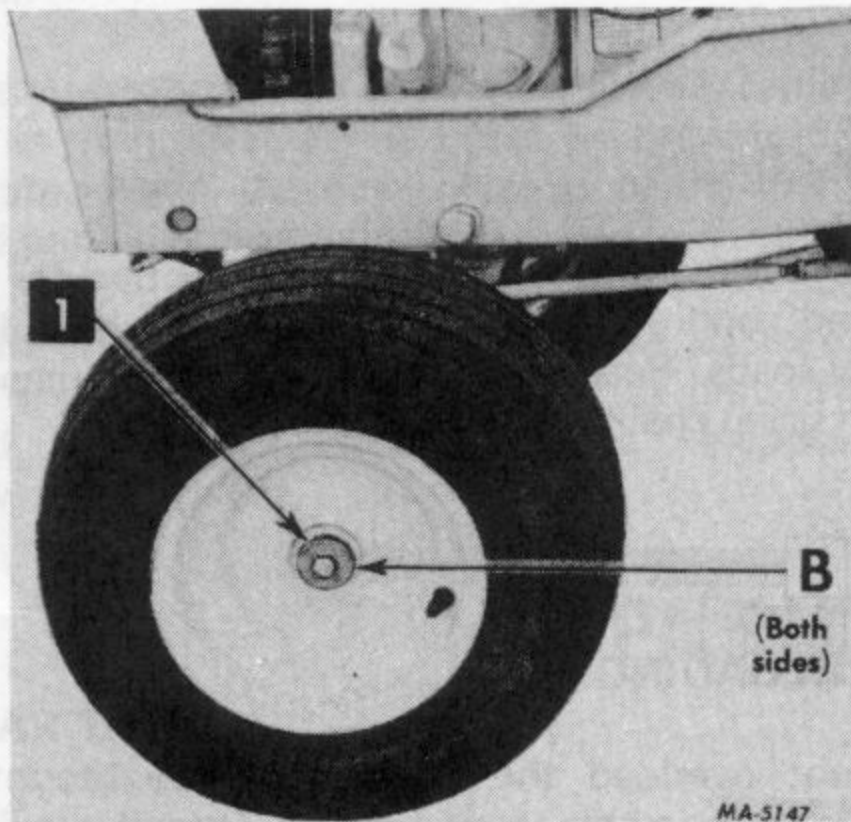

1. Wheel hub

Front wheel adjustments.

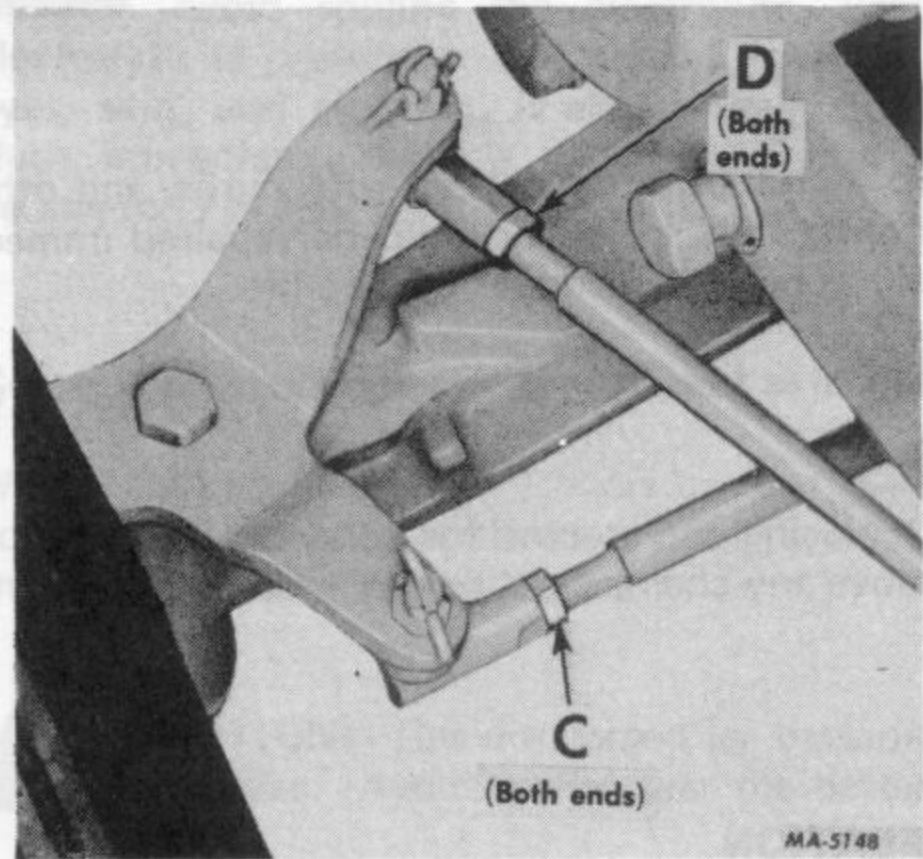

Tie rod and drag link ball joints.

The front wheel toe-in dimension is approximately 1/8-inch closer in front than in the rear. To measure for proper toe-in, make a chalk mark on the centerline of each tire the same height from the ground as the front wheel hubs. Measure the distance between the marks "A", then rotate the tires so that the marks are toward the rear of the tractor, the same height from the ground as they were in front. The dimension should be approximately 1/8-inch larger at the rear. See "B."

To adjust the toe-in remove one ball joint, loosen the lock nut "C" at the ball joint and turn the tie rod ball joint in or out as required.

TURNING RADIUS

The front wheel should have an equal angle for left and right turns. If adjustment is necessary, remove ball joint and loosen lock nut "D", turn the drag link ball joint clockwise or counterclockwise as required.



CAUTION! Be sure all parts are re-assembled tight with cotter pins in place and spread.

CLUTCH-BRAKE

International Cub Cadet 86, 108 and 128 Tractors

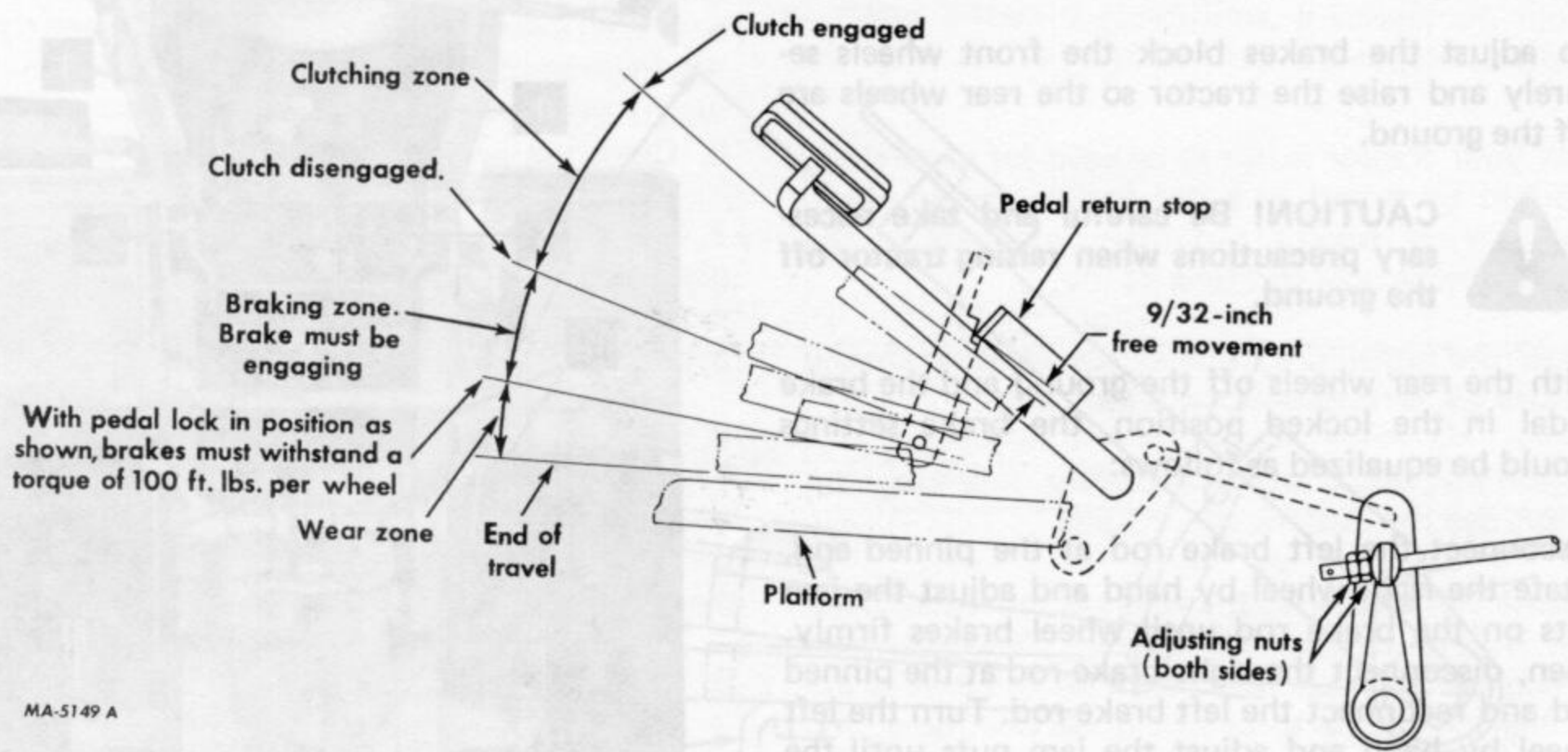

ADJUSTING THE CLUTCH

It is important that a clearance of .050-inch be maintained between the clutch release lever and the clutch release bearing. In order to maintain this clearance, the pedal should have a free movement of approximately 9/32-inch. This measurement is taken at the point of contact of the pedal arm with the front edge of the pedal return stop.

The clutch pedal adjustments are set at the factory and should not require frequent attention unless the linkage has been disturbed or when the pedal movement becomes less than 9/32-inch. When it is necessary to adjust the clutch, turn the adjusting nut (No. 3 on page 29) on the clutch release rod in or out as required to get the proper measurements.

ADJUSTING THE BRAKES

Adjust to 100 ft. lbs. per wheel as shown in illustration. If necessary tools are not available, adjust as follows:

The disc brakes should start to engage when the pedal is pressed down to a position where the engine clutch starts to release.

Push the pedal down until the clutch just begins to release. This can be checked by shifting the transmission into third gear and rocking the tractor back and forth. If the drive shaft turns free and does not turn the engine, the clutch is disengaged. Locate the pedal at this point with a "C" clamp and adjust the jam nuts on both brake rods until the brakes just begin to clamp the brake discs and create some drag. Make sure the brakes completely release when the pedal is up against the stop, and then tighten the jam nuts.

The tractor transmission should shift easily when the tractor is stopped and the clutch-brake pedal is depressed.

NOTE: To check the equalization of the brakes, drive the tractor in third gear on a concrete or blacktop surface. When making a sudden stop, both wheels should start to slide simultaneously. If one wheel stops before the other, make the proper adjustment to obtain uniform braking of both wheels.

CLUTCH-BRAKE

ADJUSTING THE BRAKES — Continued

To adjust the brakes block the front wheels securely and raise the tractor so the rear wheels are off the ground.



CAUTION! Be careful and take necessary precautions when raising tractor off the ground.

With the rear wheels off the ground and the brake pedal in the locked position, the brake settings should be equalized as follows:

Disconnect the left brake rod at the pinned end, rotate the right wheel by hand and adjust the jam nuts on the brake rod until wheel brakes firmly. Then, disconnect the right brake rod at the pinned end and reconnect the left brake rod. Turn the left wheel by hand and adjust the jam nuts until the wheel brakes firmly. Reconnect the right rod.

NOTE: To check the equalization of the brakes start the engine and shift the gears to third speed. After the wheels are turning apply the brakes. Both wheels should stop at the same time. If one wheel stops and the other wheel continues to revolve when the brakes are applied, stop the engine, adjust the jam nuts on the brake rod of the wheel that does not stop, enough so that both wheels stop simultaneously.

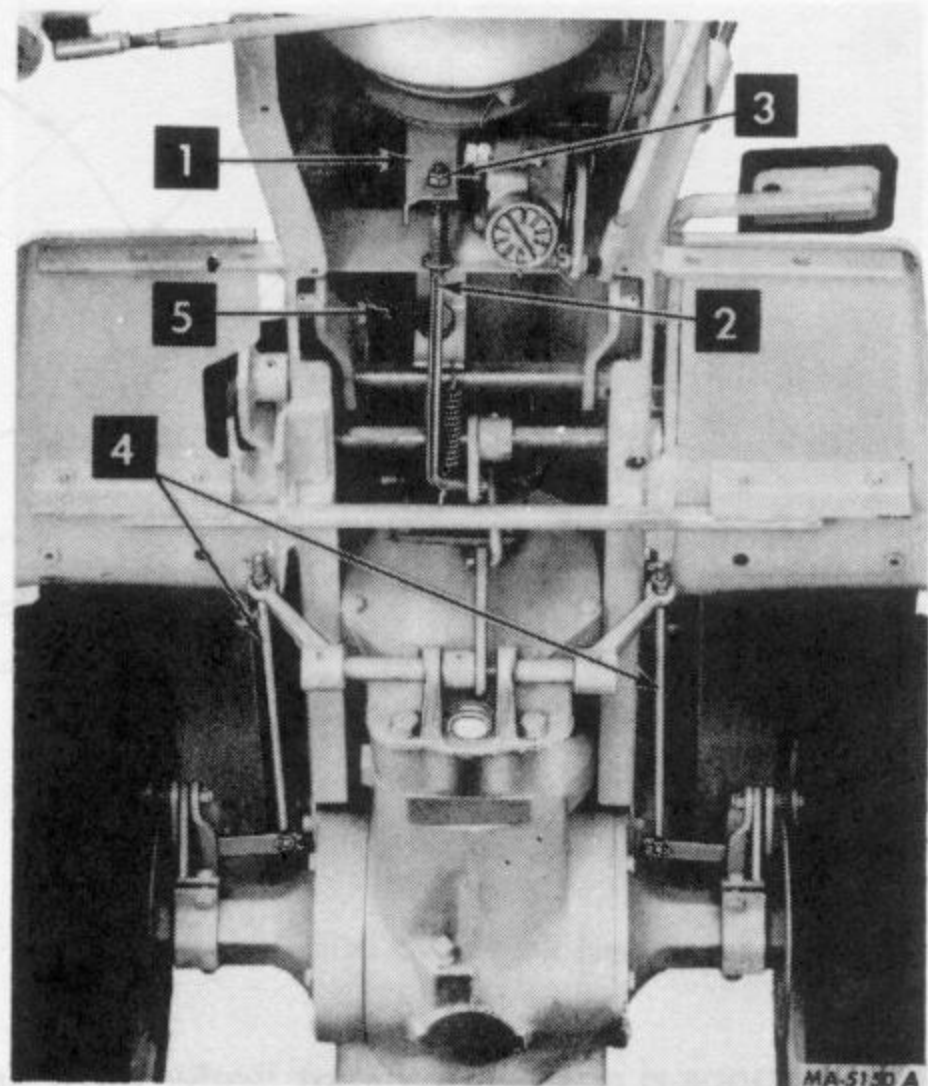

1. Clutch release lever
2. Clutch release rod
3. Adjusting nut
4. Brake rods
5. Safety starting switch

BRAKES

International Cub Cadet 129, 149 and 169 Tractors

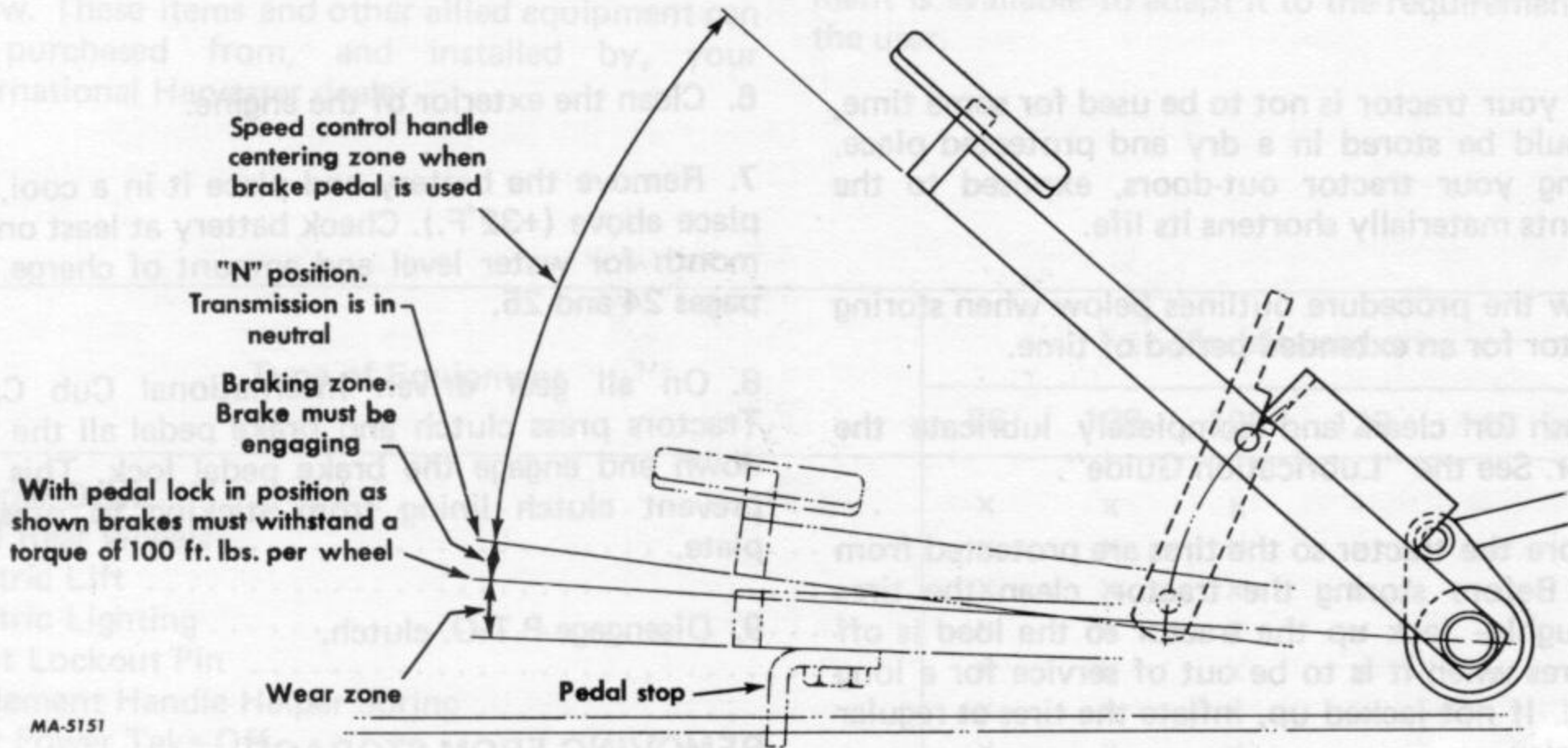

Brake adjustments.

ADJUSTING THE BRAKES

The disc brakes should engage when the pedal is pressed down to within a maximum of 1-3/16-inches and a minimum of 3/4-inch above the pedal stop.

The brake is engaged when the pedal arm is at least 3/4-inch above the pedal stop.

To adjust the brakes block the front wheels securely and raise the tractor so the rear wheels are off the ground.

NOTE: The brakes must not engage before the pedal is within the maximum distance of 1-3/16-inches.

With the rear wheels off the ground and the brake pedal in the locked position, the brake settings should be equalized as follows:

Disconnect left brake rod at the pinned end, rotate the right wheel by hand and adjust the jam nuts on the brake rod until the wheel brakes firmly. Then, disconnect the right brake rod at the pinned end and reconnect the left brake rod. Turn the left wheel by hand and adjust the jam nuts until the wheel brakes firmly. Reconnect the right rod.

STORING THE TRACTOR

When your tractor is not to be used for some time, it should be stored in a dry and protected place. Leaving your tractor out-doors, exposed to the elements materially shortens its life.

Follow the procedure outlines below when storing a tractor for an extended period of time.

1. Wash or clean and completely lubricate the tractor. See the "Lubrication Guide".
2. Store the tractor so the tires are protected from light. Before storing the tractor, clean the tires thoroughly. Jack up the tractor so the load is off the tires when it is to be out of service for a long period. If not jacked up, inflate the tires at regular intervals.



CAUTION! If tractor is jacked up or placed on blocks, be sure it is done so it cannot be tipped over or fall on someone.

3. Run the engine long enough to thoroughly warm the oil in the crankcase and then drain the oil. Refill the crankcase with fresh oil as specified in the "Lubrication Table" and run the engine for about five minutes.

4. Drain the fuel tank and run the engine until the fuel is exhausted from the fuel system.

NOTE: Gum will eventually form in the fuel tank, line, and carburetor if the unit is not drained.

5. After the engine has cooled, remove the spark plug and pour two tablespoonsful of a rust inhibited oil such as Hy-Tran® or IH No. 1® engine oil into the cylinder. Crank engine slowly turning generator belt by hand to distribute the oil over the cylinder walls. Then replace spark plug.

6. Clean the exterior of the engine.

7. Remove the battery and place it in a cool, dry place above (+32°F.). Check battery at least once a month for water level and amount of charge. See pages 24 and 25.

8. On all gear driven International Cub Cadet Tractors press clutch and brake pedal all the way down and engage the brake pedal lock. This will prevent clutch lining from sticking to pressure plate.

9. Disengage P.T.O. clutch.

REMOVING FROM STORAGE

1. Fill the fuel tank and be sure the grade of oil in the crankcase is according to the temperature range in the "Lubrication Table".

2. Install a fully charged battery and properly connect.

3. Start the engine and let it run slowly. Do not accelerate it rapidly or operate at high speed immediately after starting.



CAUTION! Keep doors wide open or release brake pedal lock and move the machine outside the storage room before engine is started to avoid the danger from exhaust gas.

4. Check air pressure in tires.

EXTRA EQUIPMENT AND ACCESSORIES

When you purchased your tractor, you probably had it completely equipped for your particular needs at the time. However, later you may wish to obtain some of the equipment or accessories shown below. These items and other allied equipment can be purchased from, and installed by, your International Harvester dealer.

The tractor is used for so many different types of work, and because it is called on to operate under so many different conditions, a variety of equipment is available to adapt it to the requirements of the user.

Type of Equipment	Models used on					
	86	108	128	129	149	169
Creeper Drive	x	x	x	—	—	—
Dual Rear Wheels	x	x	x	x	x	x
Electric Lift	x	x	x	x	—	—
Electric Lighting	x	x	x	x	—	—
Float Lockout Pin	x	x	x	x	x	x
Implement Handle Helper Spring	x	x	x	x	—	—
Rear Power Take-Off	x	x	x	—	—	—
Rear Wheel Weights	x	x	x	x	x	x
Three-Point Hitch	x	x	x	x	x	x
Tire Chains	x	x	x	x	x	x
Tractor Cover	x	x	x	x	x	x
Utility Box	x	x	x	x	x	x

TROUBLE SHOOTING

Possible Cause

Possible Remedy

HARD TO START

No gasoline in fuel tank or carburetor	Fill the tank with gasoline; open the fuel shut-off valve. Check the fuel line, and carburetor.
Fuel line or carburetor clogged	Clean the fuel line and carburetor with acetone or 50-50 mixture of alcohol and benzol.
Water in gasoline	Drain the fuel tank and carburetor. Use new fuel and dry the spark plug.
Choked improperly. Flooded engine	Follow the starting instructions.
Defective ignition or loose wiring	Check the wiring, spark plug, or breaker.
Defective battery	Check and service; See page 24 , or replace.
Spark plug dirty or improper gap	Clean, adjust the gap to .025 inch, or replace the plug.

*See your International Harvester dealer.

TROUBLE SHOOTING

The tractor is used for so many different types of work, and because it is so versatile, it may be equipped with some of the accessories shown below. These items and their operation are described in the manual. When you purchased your tractor, you probably had it completely equipped for your particular needs at the time. If you wish to obtain some of the equipment or accessories shown below, these items and their operation are described in the manual.

Possible Cause

Possible Remedy

ENGINE OPERATES IRREGULARLY OR KNOCKS

Engine incorrectly timed	*
Spark plug dirty; wrong gap or wrong type	Clean, reset the gap to .025 inch, or replace.
Poor or weak spark	Check the breaker points and breaker point opening, spark plug, and wiring.*
Carburetor setting incorrect	Adjust; see "Carburetor" on pages 10 and 11.
Poor grade fuel or water in fuel	Drain and use a good grade of clean fuel.
Engine overheating	See "Engine Cooling" See page 21.
Engine valves at fault	*
Engine smokes	Adjust the carburetor. Check for worn piston and rings.*
Other engine problems	*

LACK OF POWER

Air cleaner clogged	Clean or replace the air cleaner element. See page 21.
Engine overheated	Reduce the load.
Engine overloaded	Run the engine until it warms up before putting it under load. See "Engine Overheats" below.*
Poor fuel, too rich, or too lean a mixture	See "Carburetor" on pages 10 and 11.
Fuel tank air vent clogged	Open the vent in the cap.
Air leakage between carburetor and engine	Clean the air cleaner as instructed on page 21. Tighten the carburetor and manifold mounting nuts.
Incorrect timing or faulty ignition	See "Spark Plug" on page 22.
Clutch slipping (Models 86, 108, and 128)	Adjust the free travel of the pedal; see page 28.
Brake drags	Adjust the brake; see pages 29 or 30.

ENGINE OVERHEATS

Insufficient cool air, dirty air intake screen, shroud, or cooling fins	Keep the air intake area and cooling fins clean; see "Engine Cooling and Air Cleaner" on page 21.
---	---

CREEPING

Speed control out of adjustment (Models 129, 149, and 169)	Refer to Service Manual.*
--	---------------------------

*See your International Harvester dealer.

LUBRICATION

ENGINE OIL - Continued

The life of any machine depends upon the care it is given. Proper lubrication is a very important part of that care.

ENGINE OIL

The engine crankcase is filled with ship-away oil. This oil may be used for the first 30 hours of engine operation at temperatures between +90 degrees F. and 0 degrees F. If temperatures are not within this range, drain the oil from the crankcase and replace with new oil as specified in the "Lubrication Table". The engine oil must be drained and replaced with new oil every 30 hours of engine operation.

We recommend I.H. No. 1[®] Engine Oil. If other than I.H. No. 1[®] Engine Oil is used, it must be designated "For Service MS". In new API Code these oils are usually designated as meeting either SD or SE requirements.

To aid starting, the selection of crankcase lubricating oils should be based on the lowest anticipated temperature until the next drain period. See page 36.

Lubricate the entire tractor, using only high quality lubricating oils and greases as specified in the "Lubrication Table". For your own protection, select only oils and greases of recognized manufacture.

Regularly check the oil levels of the engine crankcase and transmission to see that they are filled to the correct levels. **NOTE:** Check the oil level only while the engine is stopped.

NOTE: On the Cub Cadet 86 Tractor the oil filler cap has the oil level gauge attached and is located on the right side of the tractor.

NOTE: On all other models the oil filler cap and gauge is located on the gear cover on the left side of the tractor.

Always keep the oil level between the "FULL" and the "LOW" marks on the gauge. When checking the oil level the gauge must be withdrawn and wiped clean, then inserted all the way and withdrawn for a true reading.

LUBRICATION

ENGINE OIL — Continued

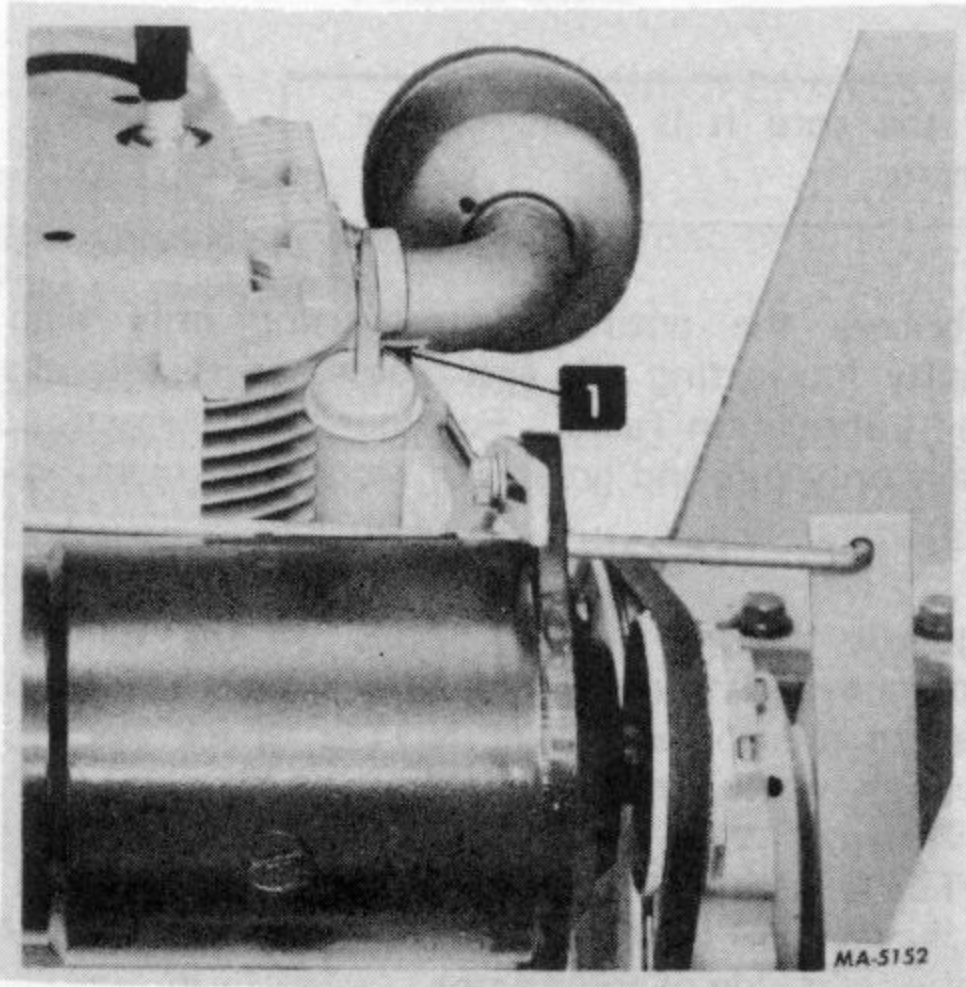

1. Oil filler cap and oil level gauge - Cub Cadet 86 Tractor

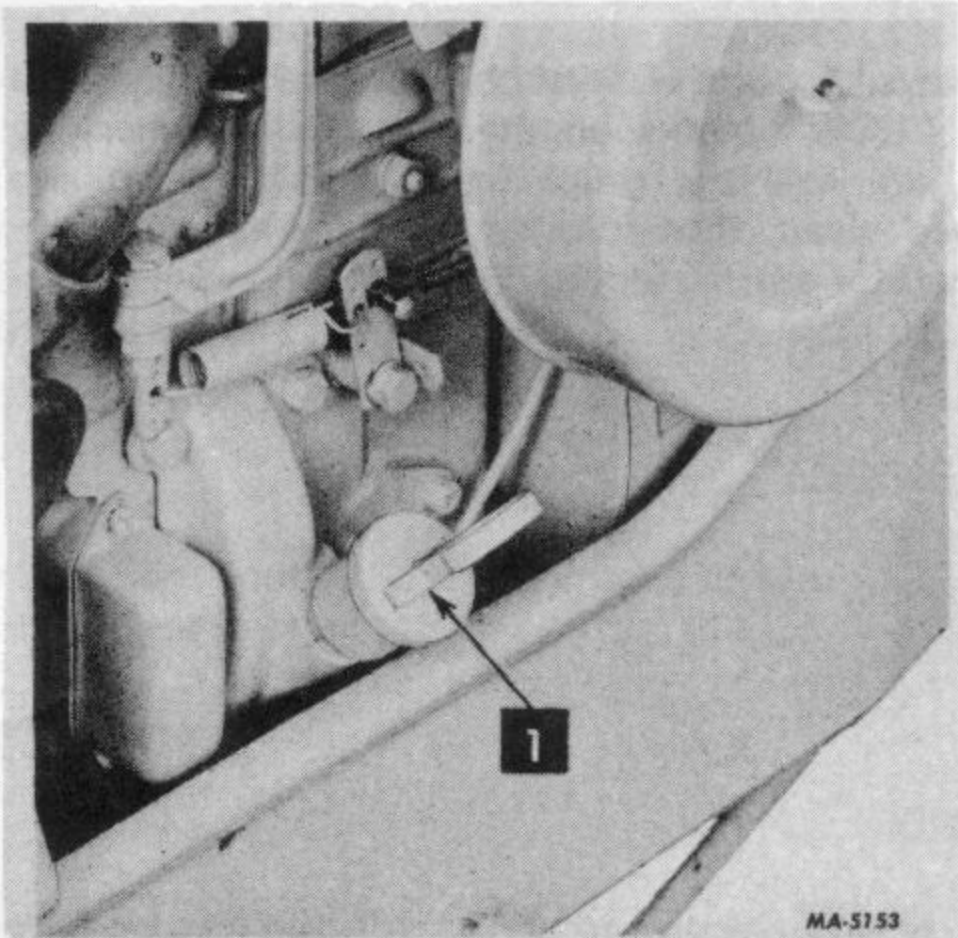

1. Oil filler cap and oil level gauge - All models except the Cub Cadet 86 Tractor

Keep your supply of lubricating oil absolutely clean and free from dust. Always use clean containers. Keep the lubricator clean and wipe dirt from the lubrication fittings before applying the lubricator.

TRANSMISSION OIL FILTER (International Cub Cadet 129, 149, and 169 Tractors)

Remove the throw-away can-type filter and replace with a new filter after the first 10 hours and after 50 hours of operation, and every 100 hours of operation thereafter.

NOTE: Clean the outside area before removing the filter to keep dirt from getting into the transmission case. If a mower is mounted on the tractor, the mower must be lowered to facilitate removal of the filter.

To remove the filter, turn the filter counterclockwise using an automotive type filter wrench or an open end wrench.

Before installing the new filter, apply a coating of oil on the filter gasket. Thread the filter on by hand until tight enough to seat the gasket. Loosen the filter. Then turn it until the gasket contacts the base. Tighten the filter an additional one half turn. Check for leaks and check oil level of transmission case.

LUBRICATION TABLE

— After Every 10 Hours of Operation

Point of Lubrication	Check at Hours	Change at Hours	Capacity	Anticipated Air Temperature		
				Above +32°F.	+32°F. to 0°F.	Below 0°F.
Engine Crankcase Model 86 Tractor	10	30	2-1/2 pt.	I.H. No. 1 [®] Engine Oil SAE-30 Note: Do not substitute 10W-30 or 10W-40	I.H. No. 1 [®] Engine Oil SAE-10W	I.H. No. 1 [®] Engine Oil SAE-5W-20 or SAE-5W Engine Oil
Engine Crankcase Models 108, 128, 129, 149, and 169 Tractors	10	30	3 pt.			
Transmission Models 129, 149, and 169 Tractors	100	Add as needed	14 pt.	<p style="text-align: center;">IH Hy-Tran[®] Fluid</p> If fluid is used which does not meet requirements of IH B-6 Specification, International Harvester Company will not be responsible for substandard performance of transmission and hydraulic components. NOTE: Failures due to use of improper fluid or filters are not covered by warranty.— FOR MAXIMUM PROTECTION USE IH HY-TRAN[®] FLUID AND FILTERS.		
Transmission Models 86, 108, and 128 Tractors	100	Add as needed	7 pt. Approx.			
Creeper drive housing Models 86, 108, and 128 Tractors	100	Add as needed	1/2 pt.			
Steering gear housing All models	Yearly	—	1/4 lb.	Two strokes of the lubricator using IH-251H EP grease or equivalent #2 multi-purpose lithium grease.		
Steering knuckles All models	10		Use IH-251 IH EP grease or equivalent #2 multi-purpose lithium grease and apply two or three strokes of the lubricator or sufficient grease to flush out old grease and dirt.			

LUBRICATION GUIDE

International Cub Cadet 86, 108 and 128 Tractors

ENGINE OIL - Continued

Keep your supply of lubricating oil absolutely clean and free from dirt. Always use clean containers. Keep the lubricator clean and free from dirt. Keep the lubricator clean and free from dirt.

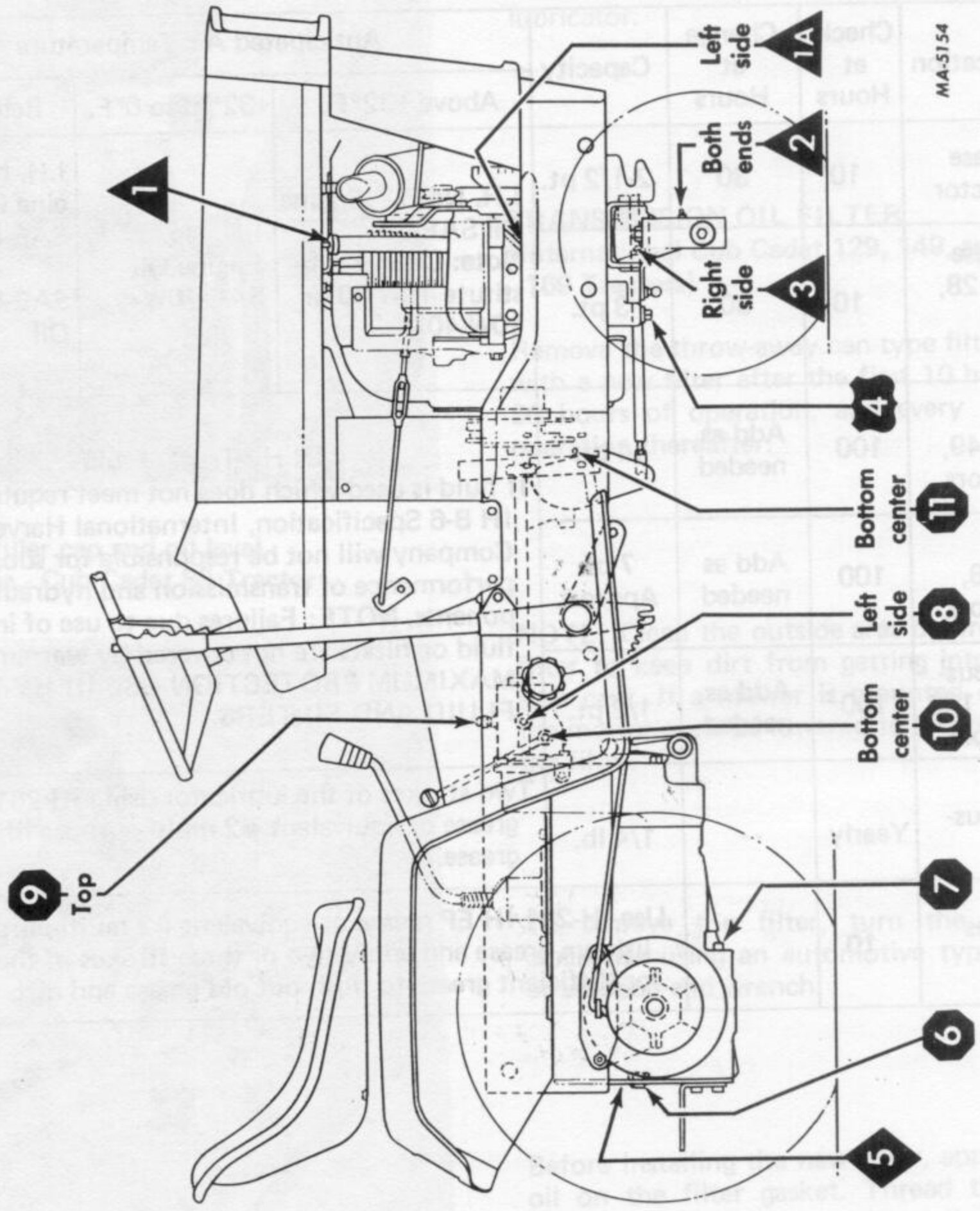

MA-5154

Lubrication view

1. Oil filler cap and oil level gauge - All models except the Cub Cadet 86 Tractor

LUBRICATION GUIDE

International Cub Cadets 86, 108 and 128 Tractors



– After Every 10 Hours of Operation

- 1 - Oil filler cap and bayonet-type oil level gauge. Cub Cadet 86.
- 1A - Oil filler cap and bayonet-type oil level gauge for Cub Cadet 108 and 128.

{ Check the oil (with the engine stopped) and add sufficient new oil to bring it to the "FULL" mark on the gauge. Do not overfill. Do not operate the engine if the oil level is below the "LOW" mark on the gauge.

- 2 - Steering knuckles (2).
- 3 - Front axle pivot pin.

{ Use IH 251H EP grease or equivalent #2 multi-purpose lithium grease and apply sufficient grease to flush out old grease and dirt.



– After Every 30 Hours of Operation

- 4 - Engine crankcase.

{ While the oil is warm, remove the drain plug (4) and drain all of the oil from the crankcase. Replace the drain plug. Refill the crankcase with new oil up to the "FULL" mark on the oil level gauge. Refer to the "Lubrication Table" for the proper quantity and viscosity to use.



– After Every 150 Hours of Operation

- 5 - Power take-off shafting bearing.

{ Use IH 251H EP grease or equivalent #2 multi-purpose lithium grease and apply two or three strokes of the lubricator to the lubrication fittings.

LUBRICATION GUIDE

LUBRICATION GUIDE

International Cub Cadet 86, 108 and 128 Tractors



– Periodic

Transmission

- 6 - Oil level and filler plug.
- 7 - Oil drain plug.

} Check the oil level periodically. Keep the lubricant up to the level plug (6) on the rear of the transmission case.

Creeper drive housing

- 8 - Level plug.
- 9 - Breather and filler plug.
- 10 - Drain plug.

} Check the oil level periodically. Keep the lubricant up to the level plug (8) on the left side of the creeper drive housing.

- 11 - Steering gear housing.

} Once a year, apply two strokes of the lubricator, using IH 251H EP grease or equivalent #2 multi-purpose lithium grease.

NOTE: To locate the lubrication fitting, remove bottom shield and turn the front wheels to the maximum right turn position. Then reach up under the right side of the tractor frame to locate the fitting.

Miscellaneous

} Lubricate the clutch pedal shaft and linkage with eight or ten drops of engine oil.

LUBRICATION GUIDE

International Cub Cadet 129, 149, and 169 Tractors

MA-5155

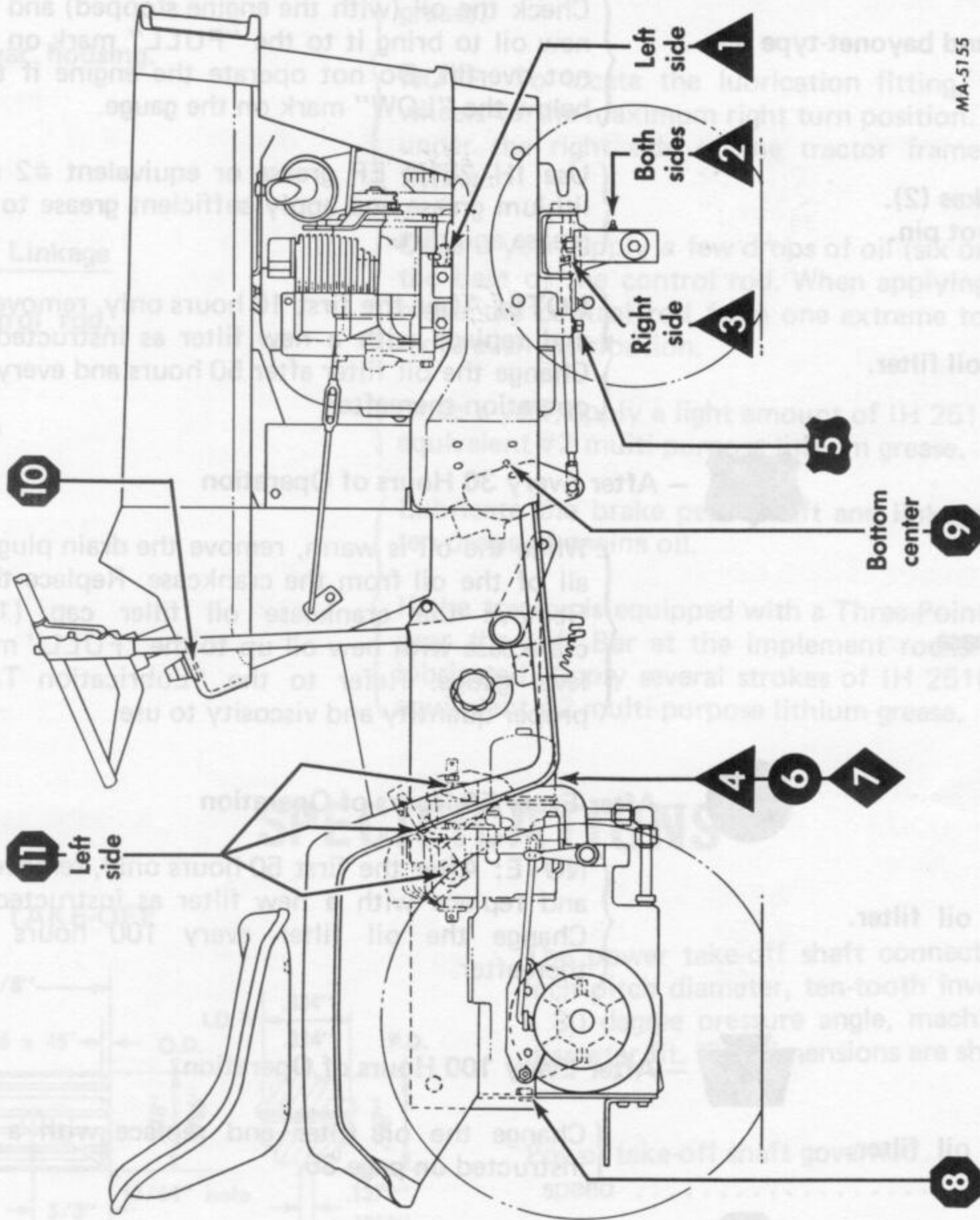

Lubrication view.

LUBRICATION GUIDE

International Cub Cadet 108, 149, and 169 Tractors

International Cub Cadet 90, 100 and 120 Tractors



– After Every 10 Hours of Operation

1. Oil filler cap and bayonet-type oil level gauge.

{ Check the oil (with the engine stopped) and add sufficient new oil to bring it to the "FULL" mark on the gauge. Do not overfill. Do not operate the engine if the oil level is below the "LOW" mark on the gauge.

2. Steering knuckles (2).
3. Front axle pivot pin.

{ Use IH 251H EP grease or equivalent #2 multi-purpose lithium grease and apply sufficient grease to flush out old grease and dirt.

4. Transmission oil filter.

{ **NOTE:** After the first 10 hours only, remove the old filter and replace with a new filter as instructed on page 35. Change the oil filter after 50 hours and every 100 hours of operation thereafter.



– After Every 30 Hours of Operation

5. Engine crankcase.

{ While the oil is warm, remove the drain plug (5) and drain all of the oil from the crankcase. Replace the drain plug. Remove the crankcase oil filler cap (1). Refill the crankcase with new oil up to the "FULL" mark on the oil level gauge. Refer to the "Lubrication Table" for the proper quantity and viscosity to use.



– After Every 50 Hours of Operation

6. Transmission oil filter.

{ **NOTE:** After the first 50 hours only, remove the old filter and replace with a new filter as instructed on page 35. Change the oil filter every 100 hours of operation thereafter.



– After Every 100 Hours of Operation

7. Transmission oil filter.

{ Change the oil filter and replace with a new filter as instructed on page 35.



– Periodic

Transmission

8. Oil level and filler plug

{ Check the oil level periodically. Keep the lubricant up to the level plug (8) on the rear of the transmission case cover.

SPECIFICATIONS

Model 86 Model 108 Model 128 Model 129 Model 149 Model 169

CAPACITIES

(APPROXIMATE —
U.S. MEASURE)

Fuel Tank	8 qt.	8 qt.	8 qt.	8 qt.	8 qt.	8 qt.
Crankcase	2-1/2 pt.	3 pt.	3 pt.	3 pt.	3 pt.	3 pt.
Transmission case	7 pt.	7 pt.	7 pt.	14 pt.	14 pt.	14 pt.
Steering gear housing	1/4 lb.	1/4 lb.	1/4 lb.	1/4 lb.	1/4 lb.	1/4 lb.
Creeper drive housing	1/2 pt.	1/2 pt.	1/2 pt.	—	—	—

TRANSMISSION GEARS

Speed: 1st	2.3 mph	2.3 mph	2.3 mph	—	—	—
2nd	3.5 mph	3.5 mph	3.5 mph	—	—	—
3rd	6.9 mph	6.9 mph	6.9 mph	—	—	—
Reverse	2.5 mph	2.5 mph	2.5 mph	—	—	—

HYDROSTATIC DRIVE

Speed: Forward	—	—	—	0 to 8 mph	0 to 8 mph	0 to 8 mph
Reverse	—	—	—	0 to 4 mph	0 to 4 mph	0 to 4 mph

ENGINE

Make and model	Kohler	Kohler	Kohler	Kohler	Kohler	Kohler
(electric starting)	K 181	K 241 A	K 301 A	K 301 A	K 321 A	K 341
Cylinders	1	1	1	1	1	1
Bore	2.938	3.250	3.375	3.375	3.500	3.750
Stroke	2.750	2.875	3.250	3.250	3.250	3.250
Displacement	16.23	23.9	29.07	29.07	31.27	35.90
Engine speed (governed)						
Low Speed	1000 rpm	1000 rpm	1000 rpm	1000 rpm	1000 rpm	1000 rpm
High idle speed (no load)	3780 rpm	3800 rpm	3800 rpm	3800 rpm	3800 rpm	3600 rpm
Full load	3600 rpm	3600 rpm	3600 rpm	3600 rpm	3600 rpm	3400 rpm
Valve clearance (engine cold)006(intake)	.010(intake)	.010(intake)	.010(intake)	.010(intake)	.010(intake)
	.017(exh.)	.020(exh.)	.020(exh.)	.020(exh.)	.020(exh.)	.020(exh.)

SPECIFICATIONS

	Model 86	Model 108	Model 128	Model 129	Model 149	Model 169
ENGINE — Continued						
Ignition (electric starting)	Battery	Battery	Battery	Battery	Battery	Battery
Spark plug gap (14mm plug) (Champion J-8 or equivalent)025 in. gap	—	—	—	—	—
(Champion H-10 or equivalent)	—	.025 in. gap	.025 in. gap	.025 in. gap	.025 in. gap	.025 in. gap
Breaker points020 in. gap	.020 in. gap	.020 in. gap	.020 in. gap	.020 in. gap	.020 in. gap
Timing	20 degrees before TDC	20 degrees before TDC	20 degrees before TDC	20 degrees before TDC	20 degrees before TDC	20 degrees before TDC

ELECTRICAL SYSTEM

System voltage	12 volt neg. ground	12 volt neg. ground	12 volt neg. ground	12 volt neg. ground	12 volt neg. ground	12 volt neg. ground
Battery	9943X	9948X	9948X	9948X	9948X	9948X
Motor generator, Delco-Remy	15 amp.	15 amp.	15 amp.	15 amp.	15 amp.	15 amp.
Voltage regulator, Delco-Remy	2 unit	2 unit	2 unit	2 unit	2 unit	2 unit
Fuse (cartridge type)	AGC-10 amp.	AGC-10 amp.	AGC-10 amp.	AGC-10 amp.	AGC-10 amp.	AGC-10 amp.

	<u>Lamp No.</u>	<u>IH Part No.</u>
Headlights — all glass, sealed beam units	4411	373 662 R91
Taillight	67	142 450

SPECIFICATIONS

FOOT BREAK

Rear wheel disc type, mechanical, on both rear wheels 8 in. dia.

CLUTCH

Double-plate, dry disc, spring loaded (Models 86, 108, and 128 Tractors) 4-1/2-in.

TIRE SIZES

Front	Models 86, 108, 128, and 129 Tractors	4.80/4.00-8
	Models 149 and 169 Tractors	16 x 6.50-8
Rear	Models 86 and 108 Tractors	6-12
	Models 128, 129, and 149 Tractors	23 x 8.50-12
	Model 169 Tractor	23 x 10.50-12

DIMENSIONS

Tread:

Front:	With 4.80/4.00-8 tires	27.0-in.
	With 16 x 6.50-8 floatation tires	28.6-in.

Rear	27.0-in.
------------	----------

Wheelbase	44-in.
-----------------	--------

Length, over-all	69-in.
------------------------	--------

Width, over-all	Models 86 and 108 Tractors	33-in.
	Models 128, 129, and 149 Tractors	36-in.
	Model 169 Tractor	38-in.

Height, over-all (to top of steering wheel)	41-in.
---	--------

Ground clearance	6-in.
------------------------	-------

Turning radius	6.6 ft.
----------------------	---------

Specifications are subject to change without notice.

OPERATING INSTRUCTIONS

INTERNATIONAL®

ROTARY MOWERS

(38, 44, and 50-inch, 3 spindle)

with wide-oval runners

and

Quick-attachable mounting

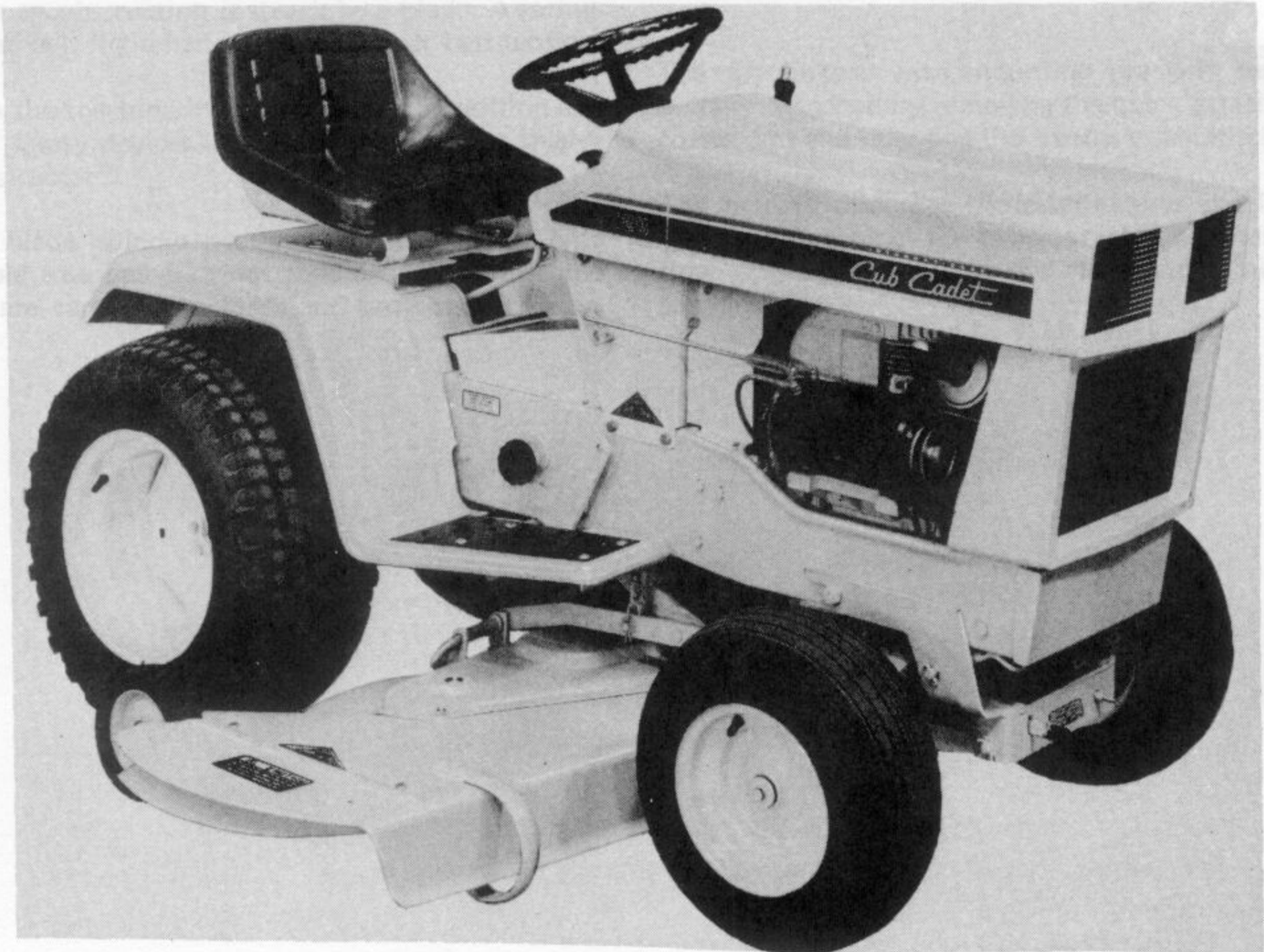

To The Owner

FOOT BREAK

Rear wheel disc type, mechanical 8 in. dia.

Your new rotary mower is designed to meet today's exacting operating requirements. The ease of operation and ability to adjust to field conditions lighten your work and shorten your hours on the job.

TIRE SIZES

Front
Models 86, 108, 128, and 148 Tractors 4.80/4.00-8
Models 149 and 169 Tractors 16 x 8.50-8
(38" and 50-inch 3 spindles)

You are urged to consult your International Harvester dealer concerning unusual field conditions or special applications. Let the experience of your dealer and the organization associated with him serve you.

Be sure to read the instructions for Adjusting and Operating in this manual. Check each item referred to and acquaint yourself with the adjustments required to obtain efficient operation and maximum trouble-free performance. Remember, a machine which is properly lubricated and adjusted saves time, labor, and fuel.

After the operating season, thoroughly clean your mower and inspect it. Preventive maintenance pays dividends. Your dealer has original-equipment parts which assure proper fit and best performance. He is able to recondition your equipment to a like new condition.

DIMENSIONS

Tractor:

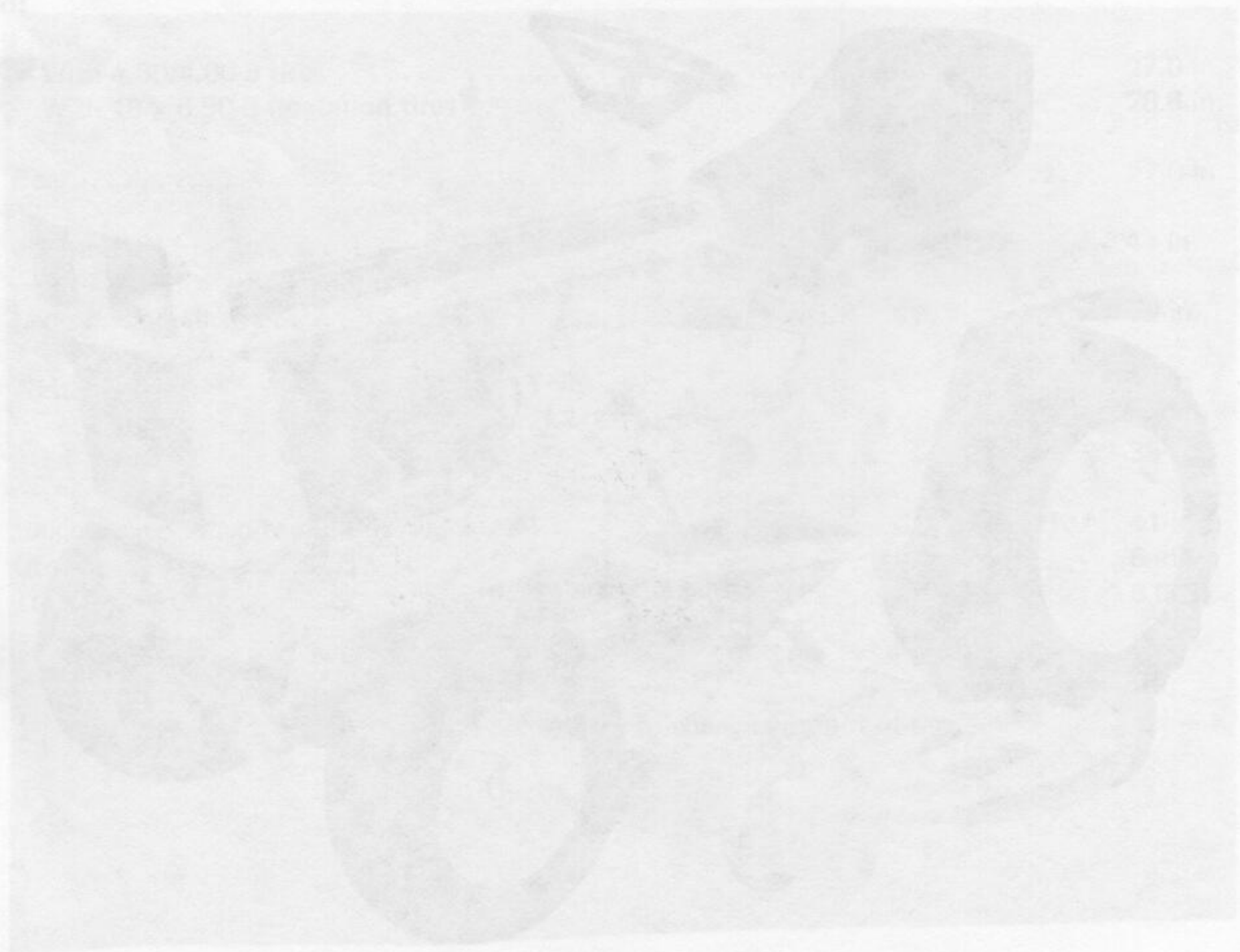

INTRODUCTION

The 3 spindle, center mounted, 38-, 44-, and 50-inch rotary mowers are designed for use on International Cub Cadet Tractors having serial number 400, 001 and higher, and are quick detachable by the use of two spring loaded handles and two bayonet type hangers.

The mower extends beyond the tractor wheels to permit cutting close to shrubbery, trees, fences, buildings, drive and walkway edges, etc.

The mower is driven by a V-belt from the engine mounted power take-off clutch. The clutch is engaged and disengaged by means of a hand lever mounted on the cowl pedestal.

A heavy-duty V-belt connects the three spindles and permits independent turning of the blades when an obstruction is struck by a blade. A spring-loaded belt tightener maintains proper belt tension.

Keep the machine in good operating condition and keep safety devices in place. Use guards or shields as instructed.

The blade spindle bearings are automotive type double row ball bearings that can be relubricated and are carefully enclosed and protected by seals.

The three cutting blades are designed to create a suction to lift the grass and hold it for an even cut.

Raising and lowering of the mower is done by means of the tractor lift handle or the power lift.

The lift linkage provides and maintains a true parallel lift for the mower. The cutting height ranges from approximately 1 to 4-inches, depending on tire and mower combinations.

Gauge wheels permit setting the cutting height to allow the mower to follow the contour of the ground and minimize ground scalping. The mower front roller also aids in minimizing scalping.

The lift linkage with mounting brackets can be quickly detached by removing the quick-attachable cotter pins and releasing the tractor quick hitch.

The tapered discharge chute terminates at a large, protected opening for efficient air and material flow across the front of the mower to minimize clogging.

1. Power take off clutch lever
2. Mower support brackets
3. Mower support devices
4. Runners
5. Lift stop
6. Hydraulic lift handle
7. V-belt tension bolt
8. Extension
9. Front lower cover
10. Quick hitch
11. Power take off clutch rod
12. Support pins (spring loaded)
13. Discharge chute
14. Extension spring
15. Gauge wheels

WORK SAFELY—FOLLOW THESE RULES



CAUTION! This symbol is used to call your attention to instructions concerning your personal safety. Be sure to observe and follow these precautionary instructions.

The discharge shield on the mower must be attached at all times while operating the mower.

Keep the machine in good operating condition and keep safety devices in place. Use guards or shields as instructed in Operator's Manual.

Children should not be allowed to operate the mower unless properly supervised, and are physically and mentally capable of safe operation.

Never place hands or feet under the mower, in the discharge chute, or near any moving parts while the tractor engine is running. Do not work on the mower with the engine running.

Never leave the tractor engine running unattended or permit it to be operated by persons not acquainted with its use and the rules for safe operation.

Stay alert for holes in terrain and other hidden hazards.

Be sure all stones, branches, or other objects that might be picked up and thrown by the mower blades are removed before starting to mow.

Do not carry passengers or give rides.

Do not allow anyone in the area opposite the discharge chute while mowing. Although the area has been supposedly cleared of foreign objects, small objects may have been overlooked and may be discharged by the mower.

Disengage power to any attachment when transporting or not in use.

It is recommended that the machine be stopped and inspected for damage after striking a foreign object and that any damage be repaired before restarting and operating the machine.

Watch out for traffic when crossing or near roadways.

OPERATING YOUR MOWER

1. Mower must be supported by the tractor.
2. Level the mower. See pages 7 and 8.
3. Engine Speed: Operate the engine at full throttle.
4. Ground Speed: Choose a ground speed that will satisfactorily handle the amount of material to be cut.

ADJUSTING AND OPERATING

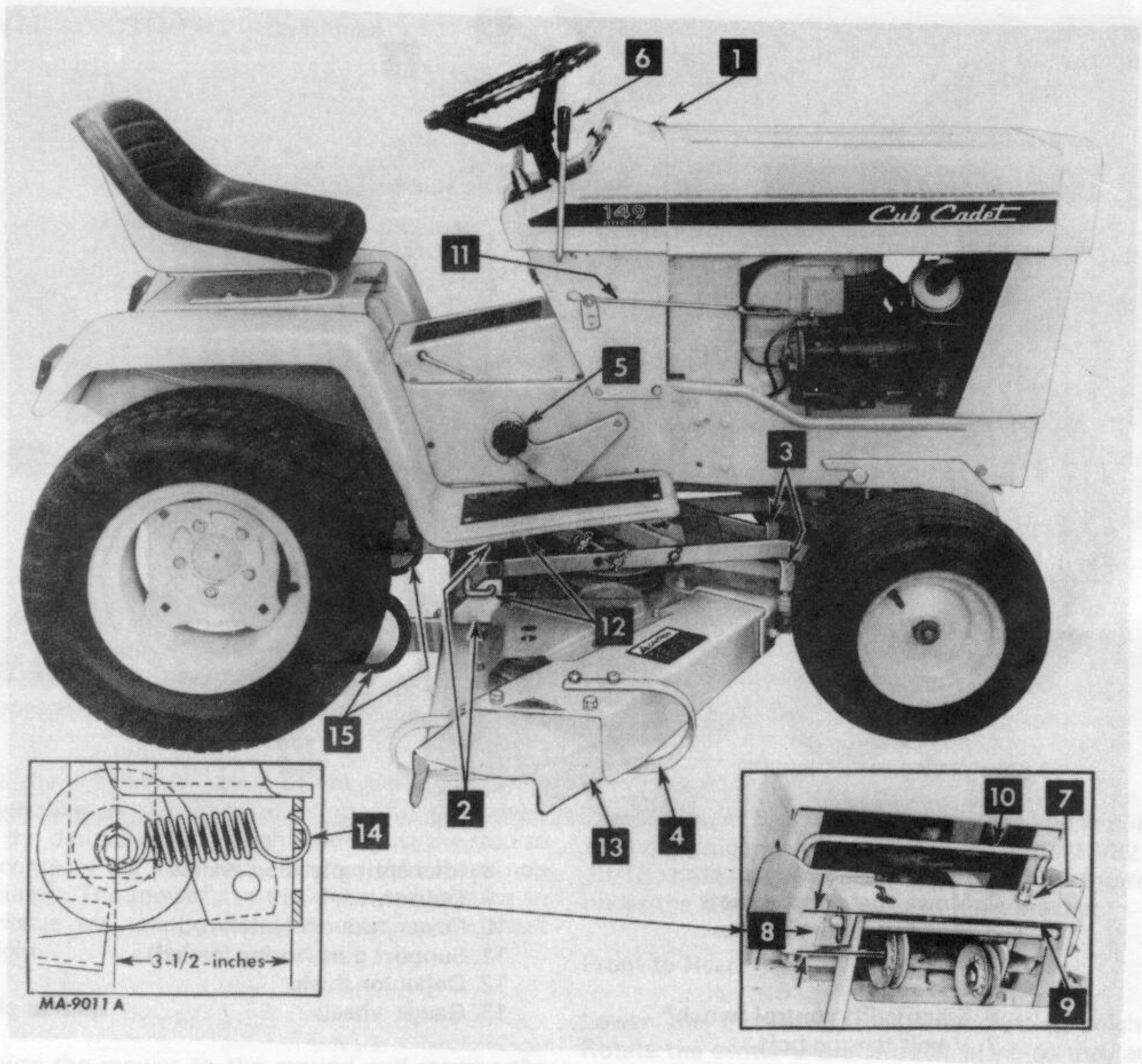

- | | |
|---------------------------------|----------------------------------|
| 1. Power take-off clutch lever | 9. Front hanger cover |
| 2. Mower support brackets | 10. Quick hitch |
| 3. Mower support clevises | 11. Power take-off clutch rod |
| 4. Runners | 12. Support pins (spring loaded) |
| 5. Lift stop | 13. Deflector shield |
| 6. Hydraulic lift handle | 14. Extension spring |
| 7. V-belt tension bolt | 15. Gauge wheels |
| 8. Extension spring measurement | |

38-inch mower.

ADJUSTING AND OPERATING

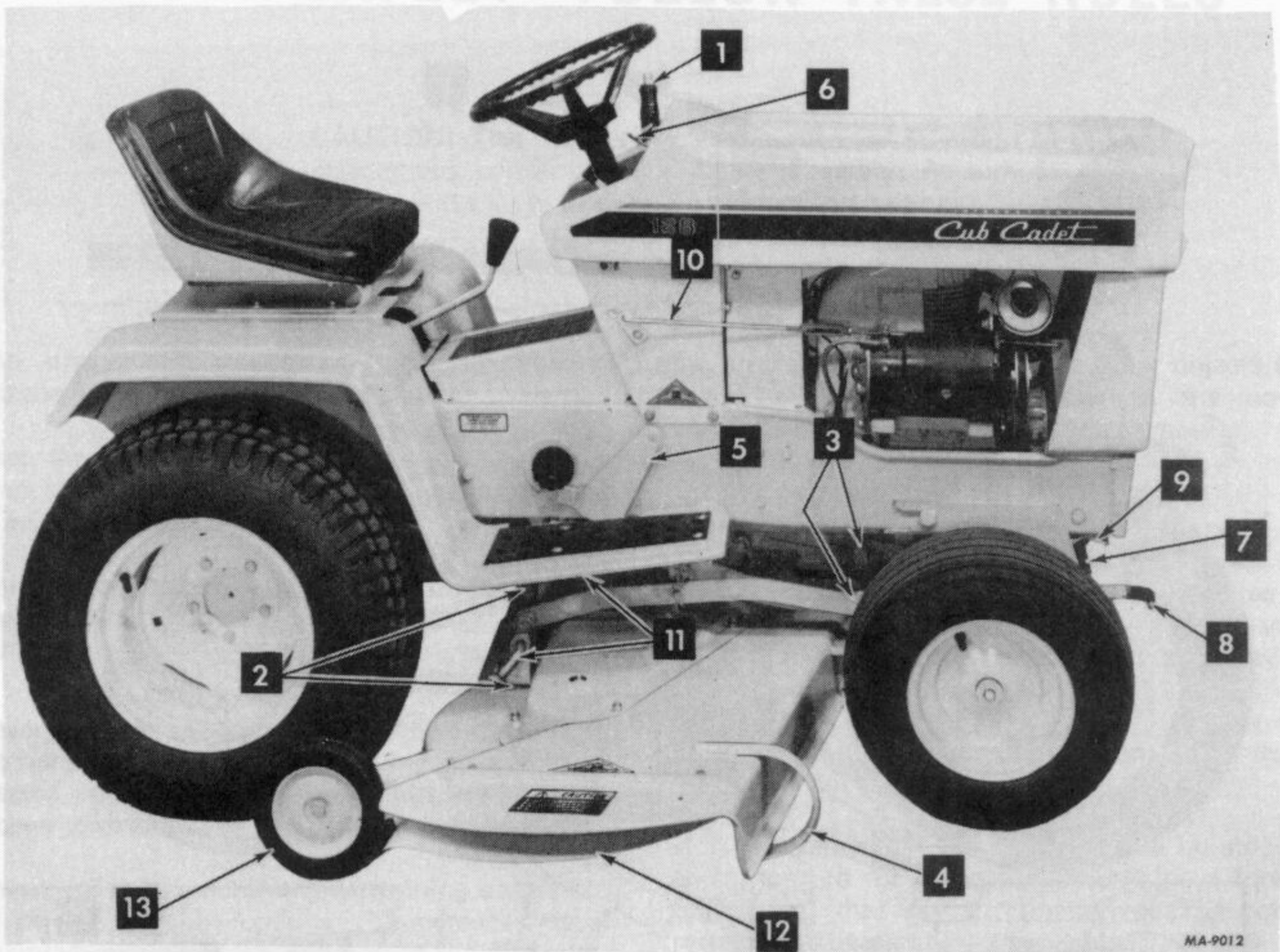

MA-9012

1. Power take-off clutch lever
2. Mower support brackets
3. Mower support clevises
4. Runners
5. Lift stop
6. Electric lift control switch*
7. V-belt tension bolt

8. Idler spring tension release
9. Quick hitch
10. Power take-off clutch rod
11. Support pins (spring loaded)
12. Deflector shield
13. Gauge wheels

44 and 50-inch mower.

*Optional Equipment

STARTING THE MOWER

With the engine operating at idle speed, slowly engage the power take-off clutch lever. Advance the throttle to full throttle.

STOPPING THE MOWER

Disengage the power take-off clutch lever (to the rear position) and reduce the engine speed.

LEVEL ADJUSTMENT

NOTE: Check the tires for proper inflation before making a level and height adjustment.

To adjust the mower for level, first place the tractor on a level surface, preferably a hard surface area such as a garage floor or sidewalk.

ADJUSTING AND OPERATING

V-BELT

LEVEL ADJUSTMENT – Continued

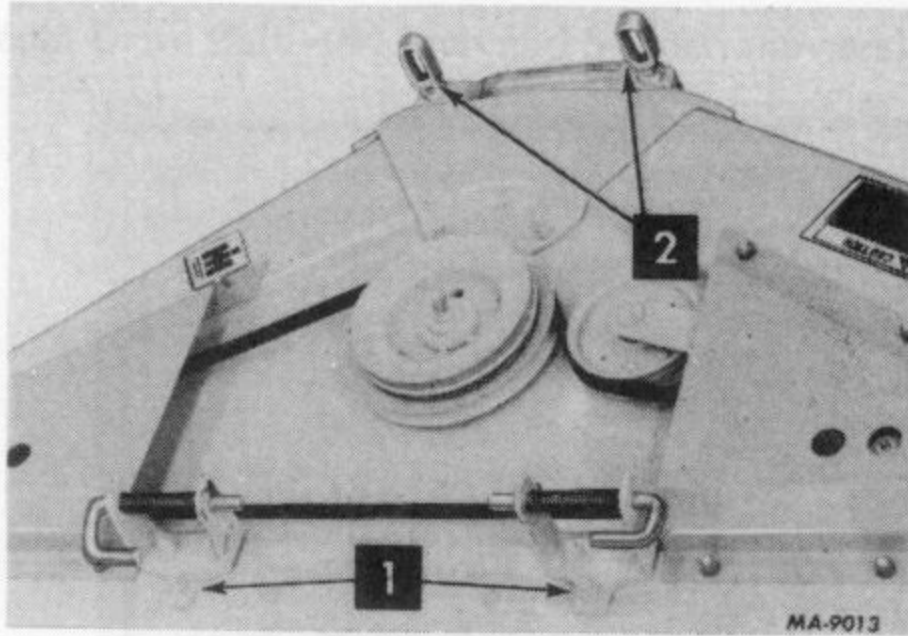

1. Support brackets
2. Support clevises

38-inch mower shown.



CAUTION! Be sure to turn off the engine, remove the ignition key, set the brake pedal in the locked position, and disengage the power take-off clutch.

Set the lift handle stop for the desired mowing height. To set the lift handle stop, raise the mower to the desired cutting height and adjust the stop so it contacts the lift handle. Then tighten the knob securely. The mower can then be raised to cross an obstacle, etc., and lowered, maintaining the preset height.

Side to Side

Lower the mower to the ground and remove the quick attachable cotter pin and flat washer securing the right lift link to the right tractor lift arm. Pitch the lift link back to clear the pin and turn the lift link clockwise or counterclockwise so the height from the top of the mower housing to the surface is equal on each side.

NOTE: (38-inch mower only) If correct side to side adjustment cannot be obtained after adjusting the lift link, proceed as follows:

Adjust the idler ratchet is in line with the slot on the cover as shown in the illustration.

NOTE: After the first half hour of mowing, check the belt for proper tension.

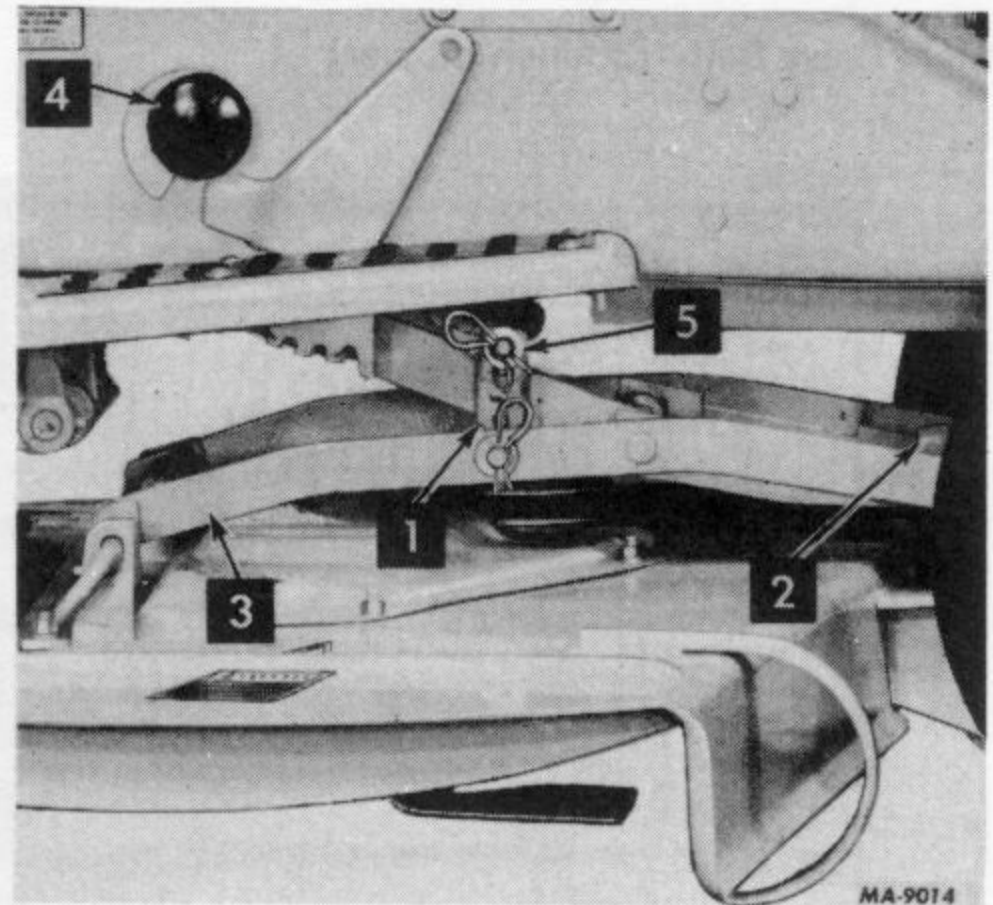

1. Adjustable lift link
2. Support clevises
3. Lift frame
4. Lift handle stop
5. Quick attachable cotter pin and flat washer.

50-inch mower shown.

Lower the mower almost to the surface making sure the gauge wheels do not touch. Add 13/32 x 13/16 x .065-inch flat washers, as many as required under the left or right mower support bracket.

Front to Rear

Lower the mower to the preset cutting height. Rotate the center and one outer blade so they are parallel and pointing straight to the front and rear. Then adjust the two support clevises at the front of the mower so the front edge of the center blade is level with the back edge of the outer blade.

NOTE: If mower is not level, it will adversely affect the performance.

If the blades are not in satisfactory condition, replace them with new pulleys available at your International Harvester dealer.

To install or remove the belt, disengage the idler ratchet to take the tension off the belt. Readjust the V-belt tension as previously described.

ADJUSTING AND OPERATING

V-BELT

Main Drive Belt—(38-inch mower)

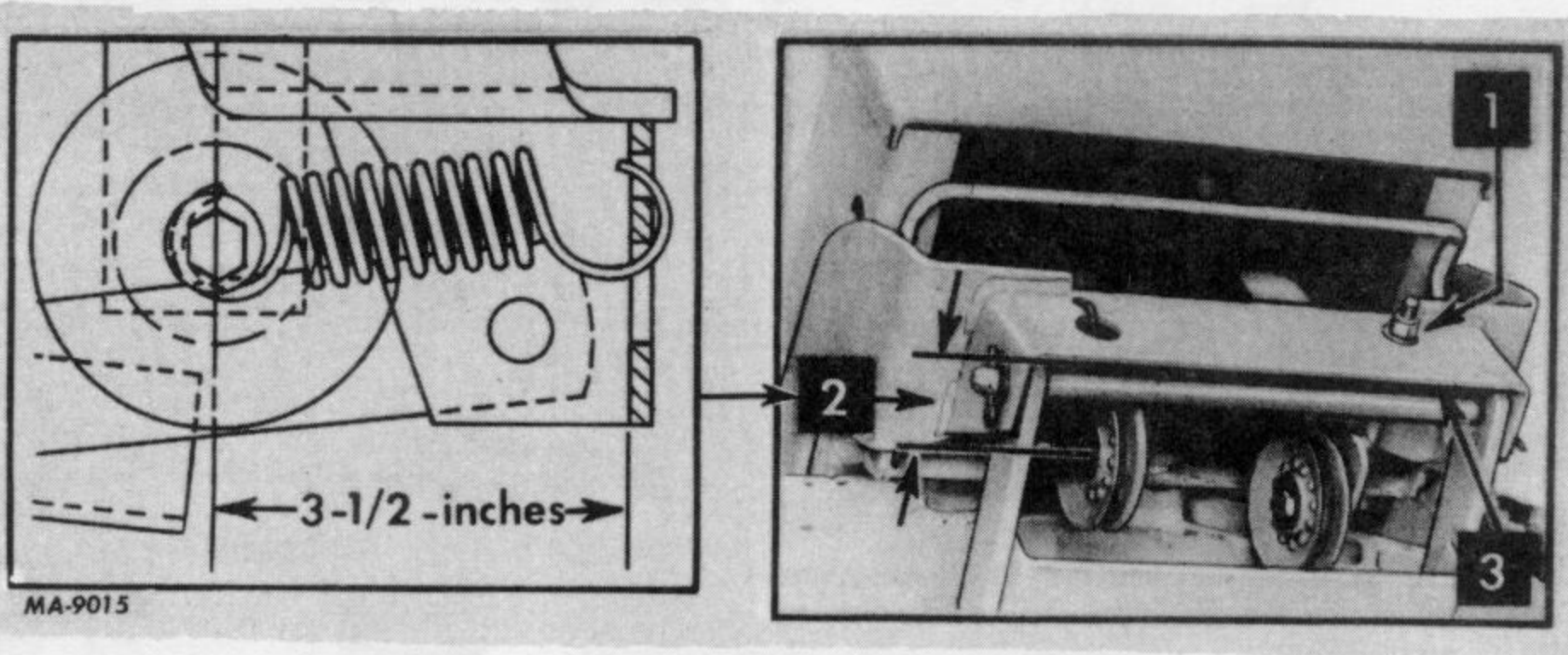

1. V-belt tension bolt
2. Extension spring measurement
3. Front hanger cover

The main drive V-belt is adjusted for tension by the V-belt tension bolt. Tighten the locknut to increase belt tension and loosen the locknut to decrease the belt tension.

When installing a new belt, the initial tension is obtained by adjusting the bolt so the distance measures approximately 3-1/2-inches from the center of the pulley (at the extension spring) to the inner face of the front hanger cover.

The main drive belt is properly tensioned when the extension spring coils are spread approximately 1/16-inch.

NOTE: After the first half hour of mowing, readjust bolt to the 3-1/2-inch dimension.

When belt slippage occurs or spring coils touch, readjust to 1/16-inch spread. Under no condition should the tension adjustment distance be allowed to fall under 3-1/8-inches.

NOTE: When installing a new belt always check the condition of the pulleys and if they are not in satisfactory condition, replace them with new pulleys available at your International Harvester dealer.

To install or remove the belt, loosen the V-belt tension bolt, raise the mower and disconnect the power take-off clutch lever rod. **NOTE:** Refer to the Front Power Take-off section of the Tractor Operator's Manual. This will provide sufficient clearance between the wear and thrust buttons on the clutch to allow V-belt to pass through. Re-adjust V-belt tension as previously described.

STOPPING THE MOWER

Disengage the power take-off clutch lever (to the rear position) and reduce the engine speed.

ADJUSTING AND OPERATING

V-BELT

Main Drive Belt—(44-inch and 50-inch mowers)

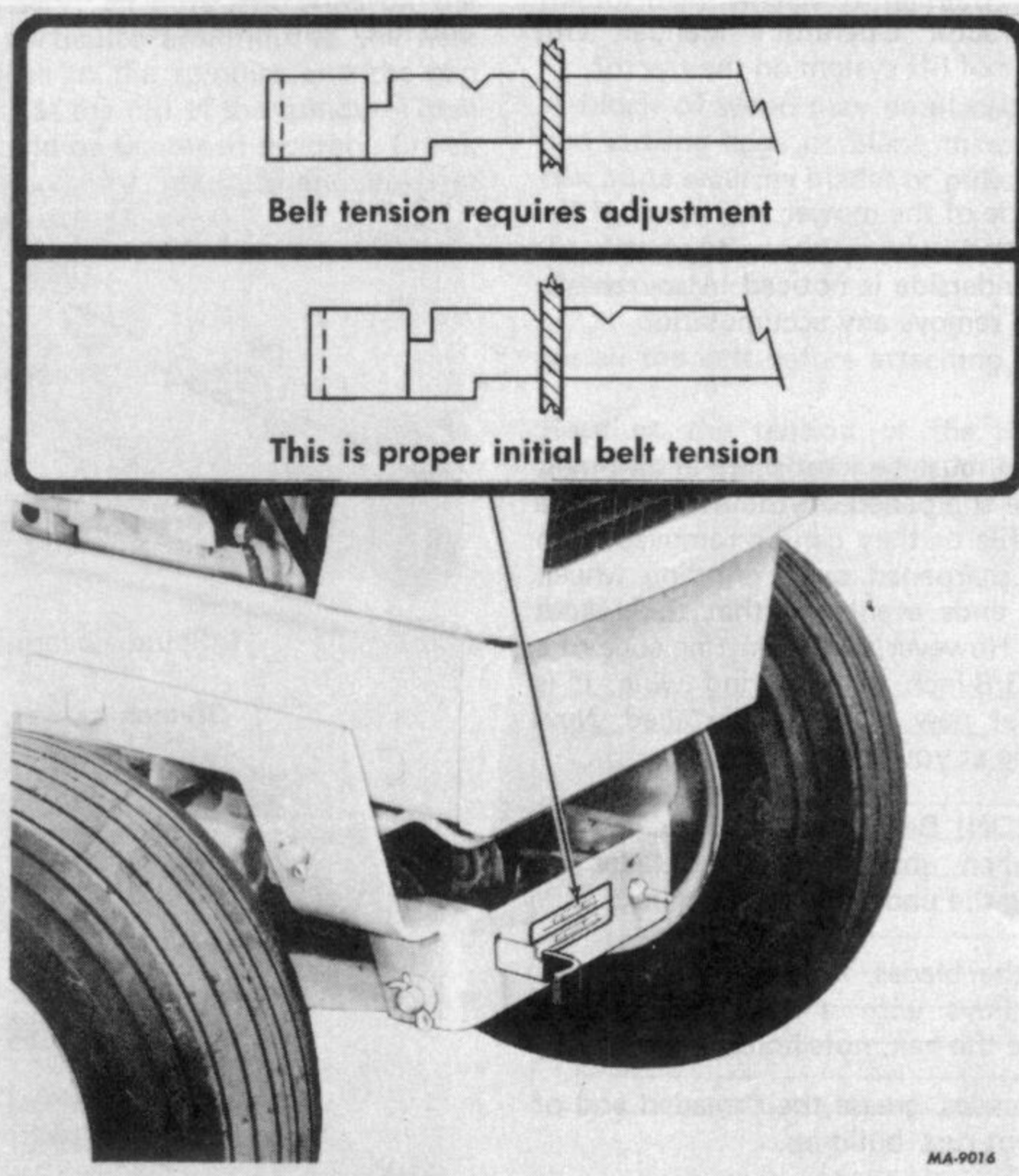

1. Front cover
2. Idler ratchet
3. V-belt tension bolt

The main drive V-belt is properly tensioned when the idler ratchet is positioned as shown on the decal on the front cover of the lift frame.

To adjust the belt for proper tension tighten the V-belt tension bolt so the notch on the idler ratchet is in line with the slot on the cover as shown in the illustration.

NOTE: After the first half hour of mowing, check the belt for proper tension.

NOTE: When installing a new belt always check the condition of the pulleys and if they are not in satisfactory condition, replace them with new pulleys available at your International Harvester dealer.

To install or remove the belt, disengage the idler ratchet to take the tension off the belt. Readjust the V-belt tension as previously described.

ADJUSTING AND OPERATING

HEIGHT OF CUT

Set the lift stop for the desired height of cut.

Refer to the Tractor Operator's Manual with respect to the type of lift system on the tractor.

CLEANING

Clean the underside of the mower at the end of the mowing season and when the build-up of cut material on the underside is noticed. Also, remove the belt cover and remove any accumulation.

BLADE CARE

The cutting blades must be kept sharp at all times. The blades can be sharpened on the mower with a few strokes of a file or they can be removed from the mower and sharpened on a grinding wheel. **NOTE:** Sharpen ends evenly so that the blades remain balanced. However, if the cutting edge of a blade is within 3/8-inch of the wind wing, it is recommended that new blades be installed. New blades are available at your IH dealer.



CAUTION! Be careful not to cut yourself when sharpening the blades or cleaning the underside of the mower.

When removing the blades, hold the welded hex. nuts on the pulleys with a 1-1/4-inch socket wrench to remove the hex. nuts holding the blades.

After replacing blades, grease the threaded end of the shaft to prevent rust build-up.

When replacing the blades, be sure they are assembled so the cutting edges are in the direction of rotation with the wind wings pointed upward and the washers assembled on top and bottom of blades, and tighten securely.

NOTE: If the spindle nuts are removed for any reason, they should be retightened to 55 to 60 foot-pounds torque when replaced.

LUBRICATION

After every 16 hours of operation, and before putting in winter storage, lubricate the spindle bearings using IH 251H EP grease or equivalent No. 2 multi-purpose lithium grease.

Also, before winter storage, remove idler pivot shaft and grease the area where the torsion spring and idler arm tube ride.

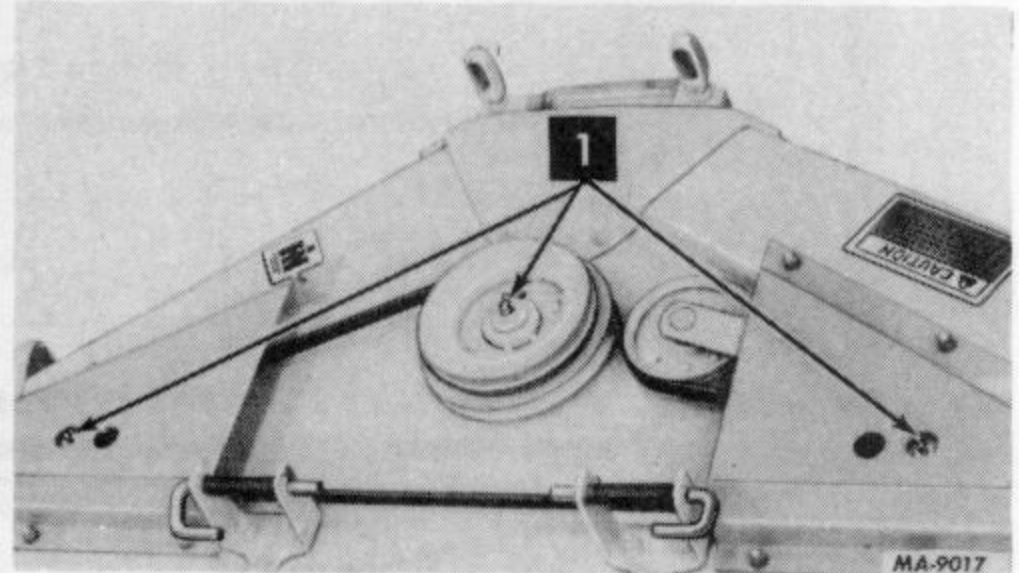

1. Spindle bearings

38-inch mower.

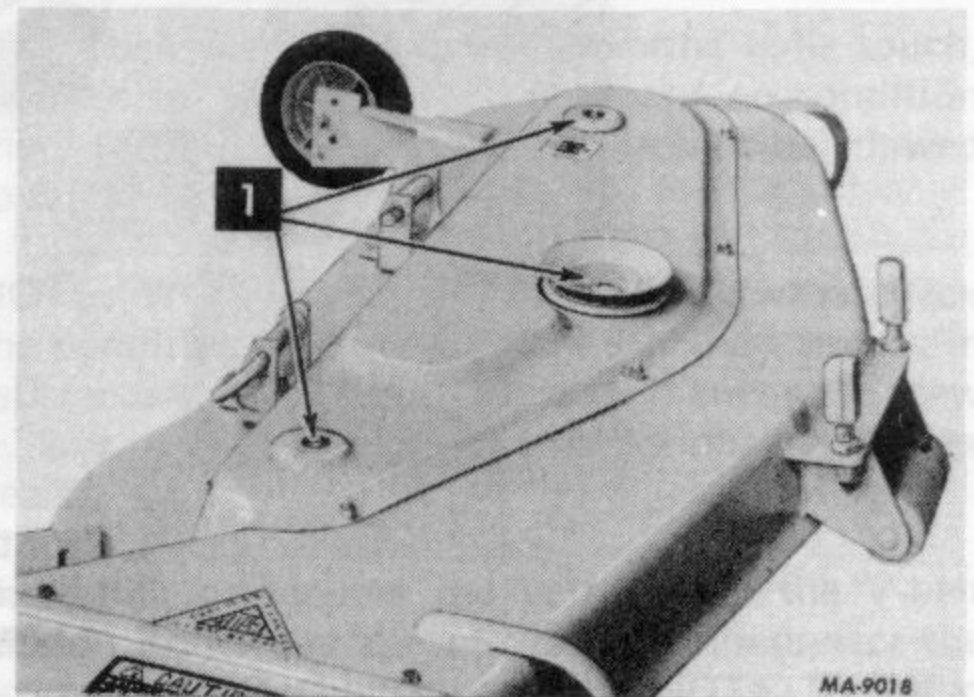

1. Spindle bearings

44-inch and 50-inch mowers.

GENERAL

After first 1/2 hour and every 4 hours thereafter of running, check the V-belt tension and adjust if necessary.

ADJUSTING AND OPERATING

GENERAL – Continued

After the first 10 hours of operation check and retighten, if necessary, all nuts and bolts on the machine, paying particular attention to the hex. nuts, securing blades to the spindles and the cap screws or hex. nuts at the top of the spindle. These nuts and bolts should be tightened securely. Check and retighten if necessary, all nuts and bolts at least once a year thereafter.

Attaching and Detaching the Mower

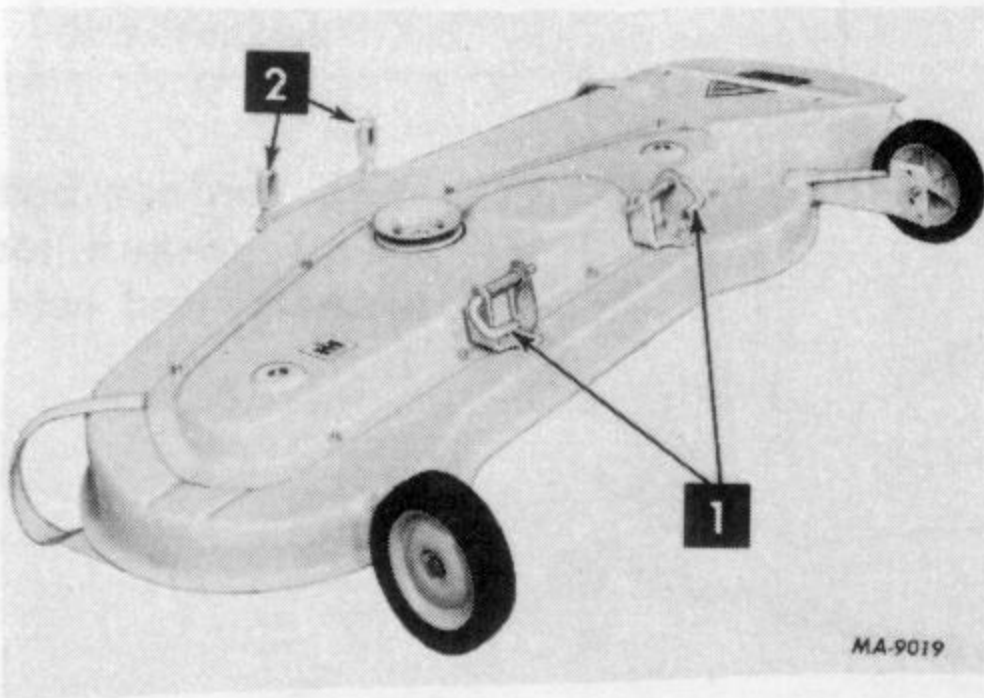

1. Spring loaded support pins
2. Support clevises

50-inch mower shown.
38 and 44-inch mowers are the same.

To facilitate changing of the blades, sharpening of the blades, cleaning, etc., the mower may be detached from the tractor in the following manner:

Pull out the left and right spring loaded support pins and turn them until the end of the "U" shaped handles rest against side of the brackets.

Move mower forward so left and right support clevises are free of the front pivot links and lower the mower to the ground. Remove the V-belt from the center pulley.

Raise the lift linkage for clearance and slide the mower out from under the tractor on the right side. To aid in removing the mower, turn the tractor front wheels to the right.

A block of wood may be placed between housing and cutting edge of blade to assist in removal of hex. nuts securing blades or pulleys.

To attach the mower to the tractor, reverse the above procedure.

Install the belt before attaching mower to tractor.

Readjust the tension of the main drive belt as previously described under V-Belt (depending on the size mower on the tractor).

MOWING

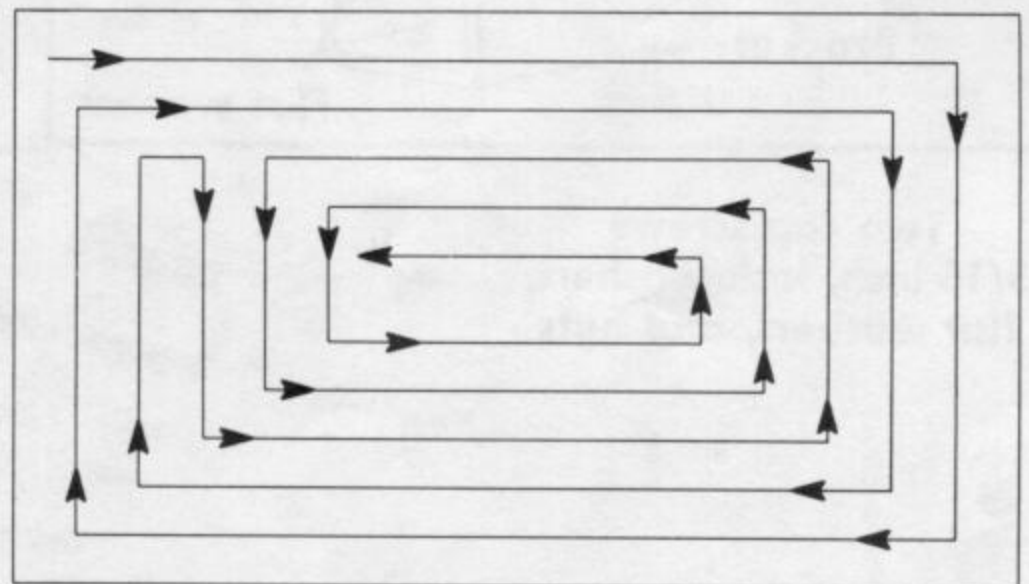

A-62943

For best results it is recommended that the first two laps should be cut with the discharge being thrown towards the center. After the first two laps, reverse the direction to throw the discharge to the outside for the balance of cutting. This will give a better appearance to the lawn.

Do not cut the grass too short, as it will give a scalping effect and invite weak growth.

SETTING UP

Remove all wires. Sort out all hardware by sizes and types in a convenient and orderly manner.

Bolts must be used in the holes in which they are found, or in the parts to which they are attached unless otherwise shown.

Lubricate all working parts as you proceed, and see that they work freely.

Whenever the terms "left" and "right" are used, it should be understood to mean from a position behind and facing the machine.

Bolts furnished with the mower are identified by three radial lines on the head. Bolts without radial lines are type 1.

STEP 1. SUPPORT CLEAVISES, BRACKETS, BELT SHIELDS, DISCHARGE SHIELD, AND RUNNERS

38-INCH MOWER

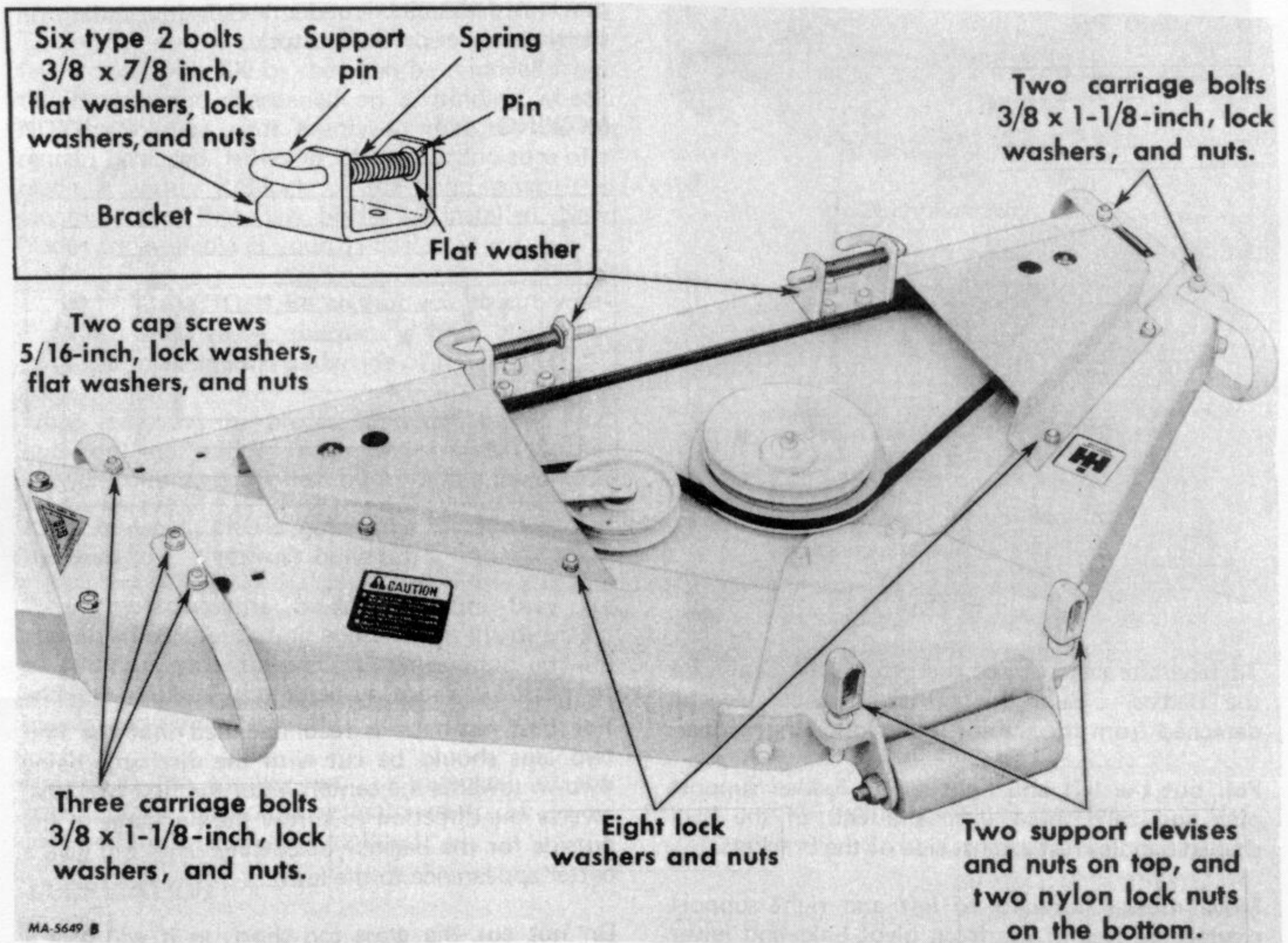

MA-5649 B

NOTE: Insert discharge shield into discharge opening of the mower as shown. Be sure all guards and shields are properly installed before operating the mower.

SETTING UP

STEP 2. GAUGE WHEEL ARMS AND GAUGE WHEELS

38-INCH MOWER

38-INCH MOWER

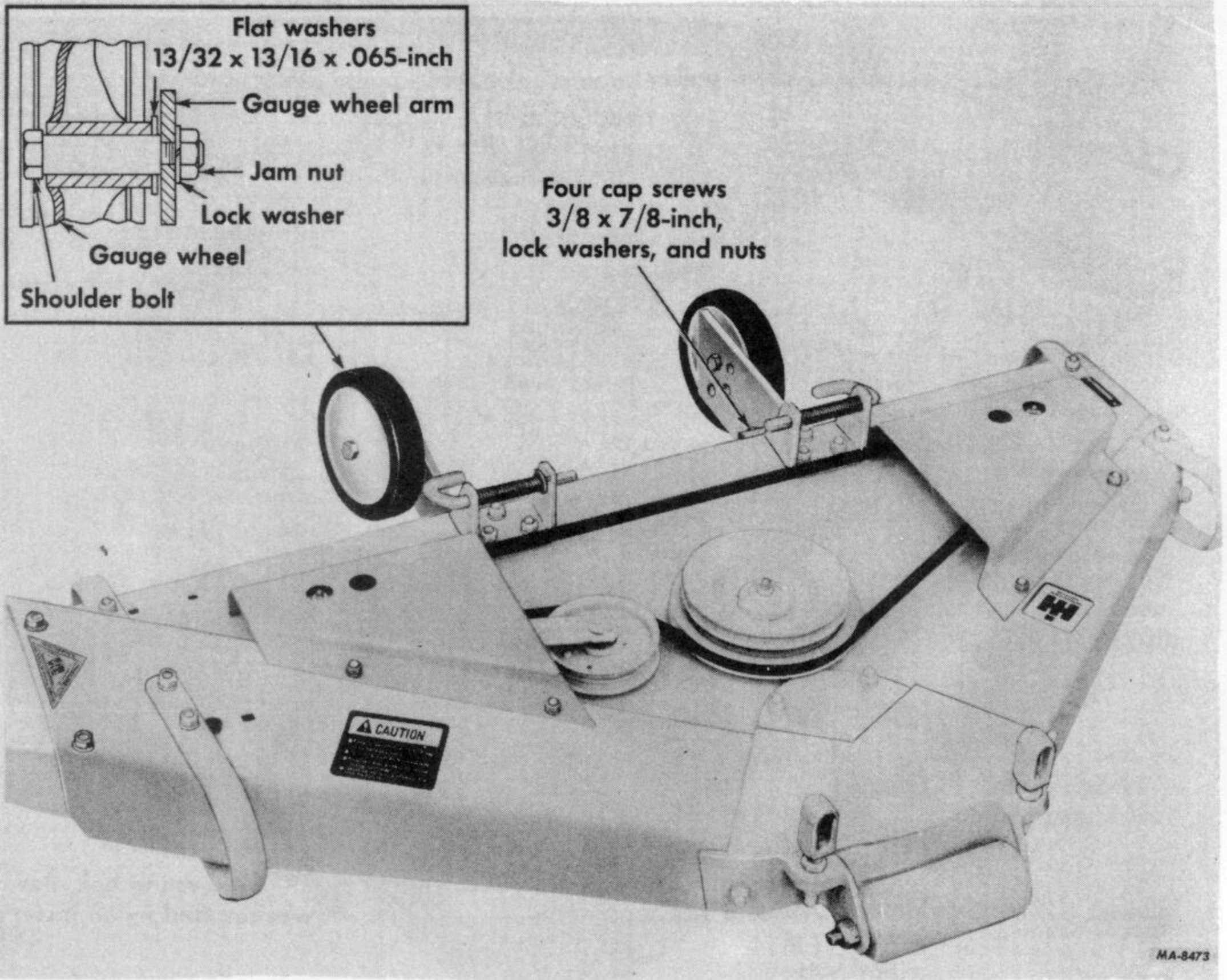

NOTE: The holes required to attach the gauge wheel arms are already drilled in the mower housing for the 38-inch mower. Attach the arms to the mower with the heads of the cap screws on the inside of the mower housing.

Check mower for correct level. If more than 1/4-inch difference, (side to side) correct. Refer to leveling instructions.

SETTING UP

STEP 3. LIFT FRAME AND FRONT HANGER ASSEMBLY

38-INCH MOWER
Bolts must be used in the holes in which they are
shown. Use the nuts to which they are attached
unless otherwise shown.

behind and facing the machine.

38-INCH MOWER

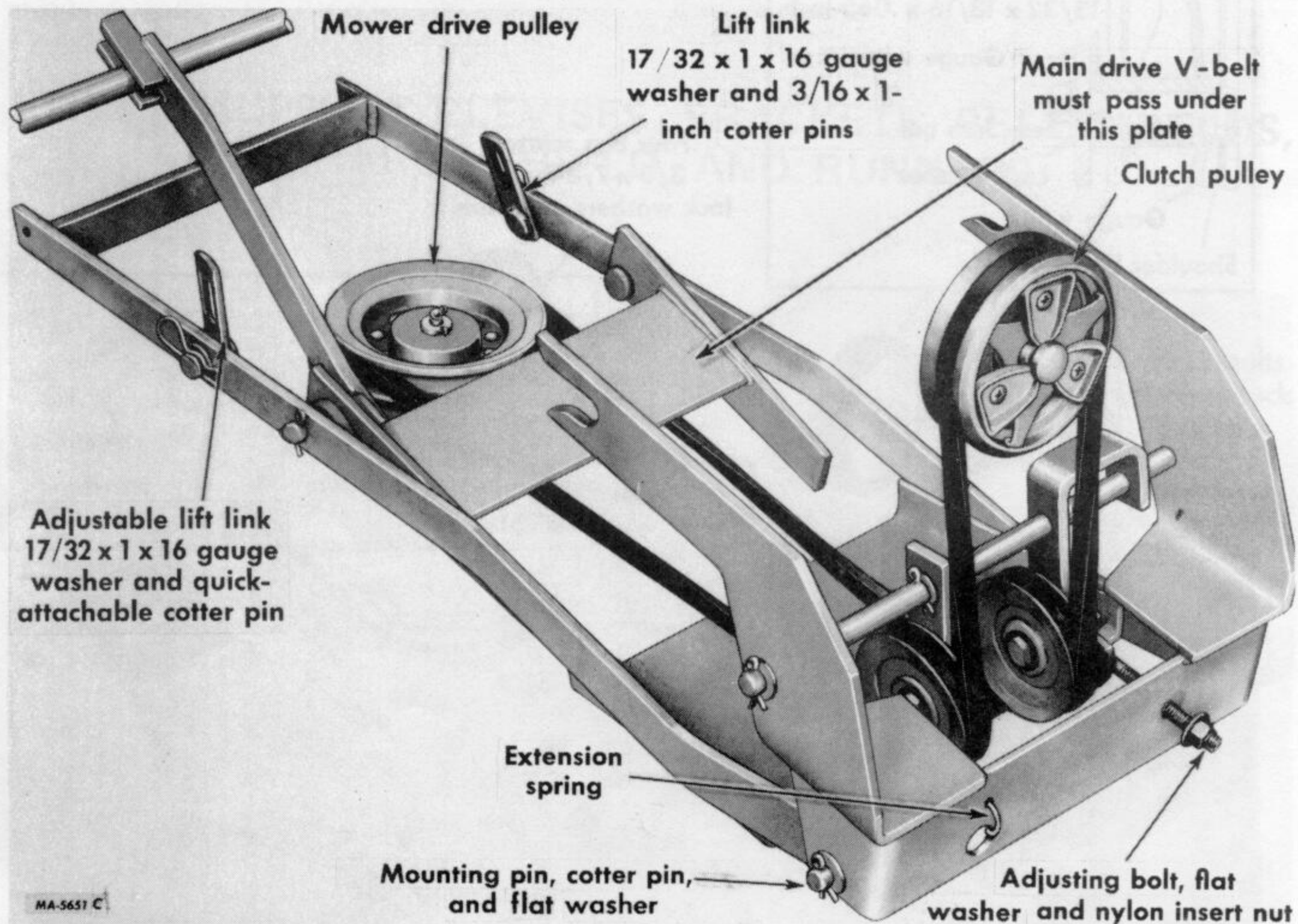

NOTE: The holes required to attach the gauge wheel arms are already drilled in the mower housing for the 38-inch mower. Attach the arms to the mower with the heads of the cap screws on the inside of the mower housing. The gauge wheel arms should be attached to the mower housing as shown in the diagram.

NOTE: Insert discharge shield into discharge opening of the mower as shown. Be sure all guards and shields are properly installed before operating the mower.

SETTING UP

STEP 4. ATTACHING LIFT FRAME ASSEMBLY TO TRACTOR

38-inch MOWER

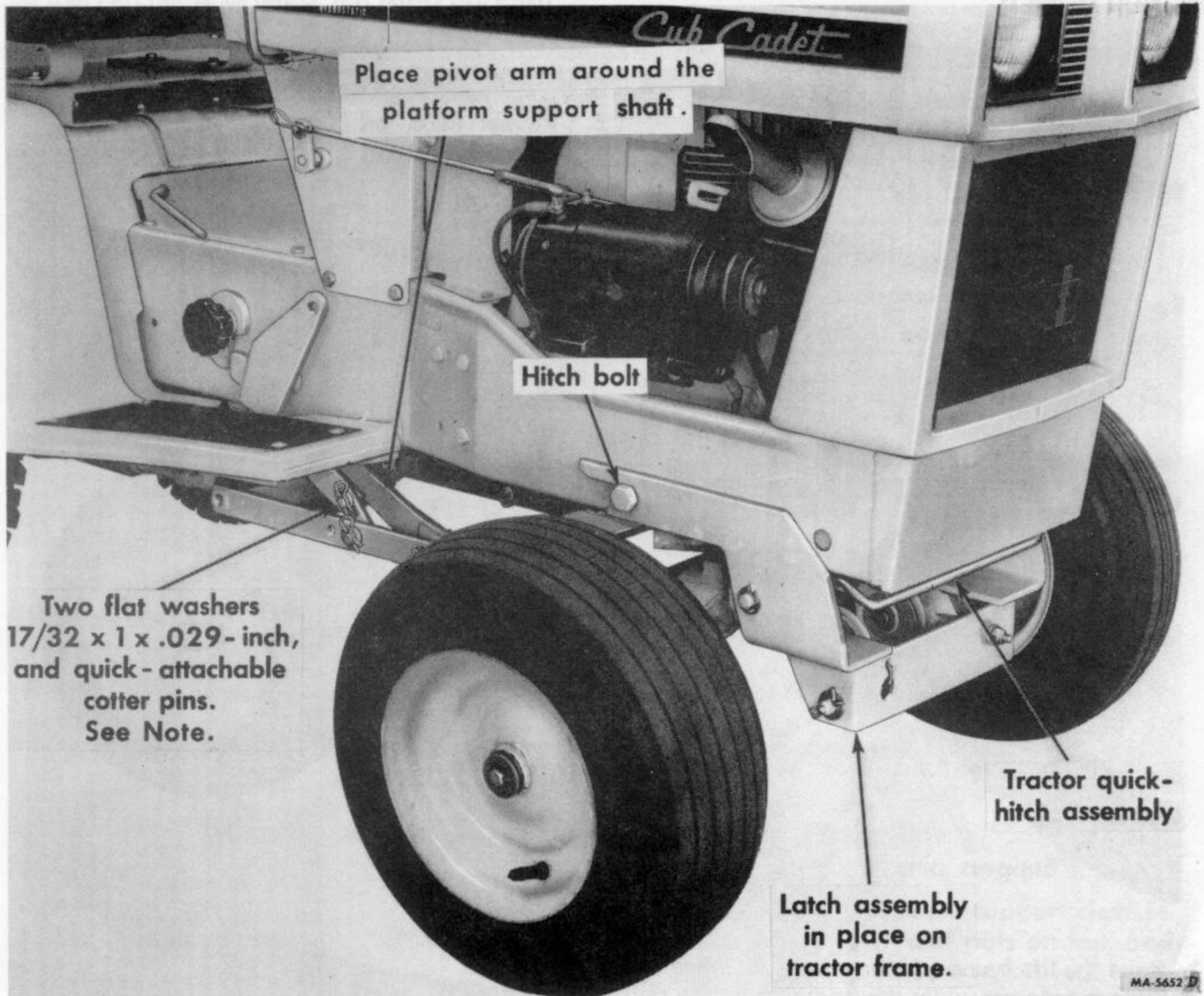

NOTE: Set the tractor lift mechanism in the lowest position before connecting the lift links to the tractor lift arms.

Check mower for correct level. If more than 1/4-inch difference, (side to side) correct. Refer to leveling instructions.

SETTING UP

STEP 5. ATTACHING MOWER TO LIFT FRAME ASSEMBLY ON TRACTOR

38-INCH MOWER

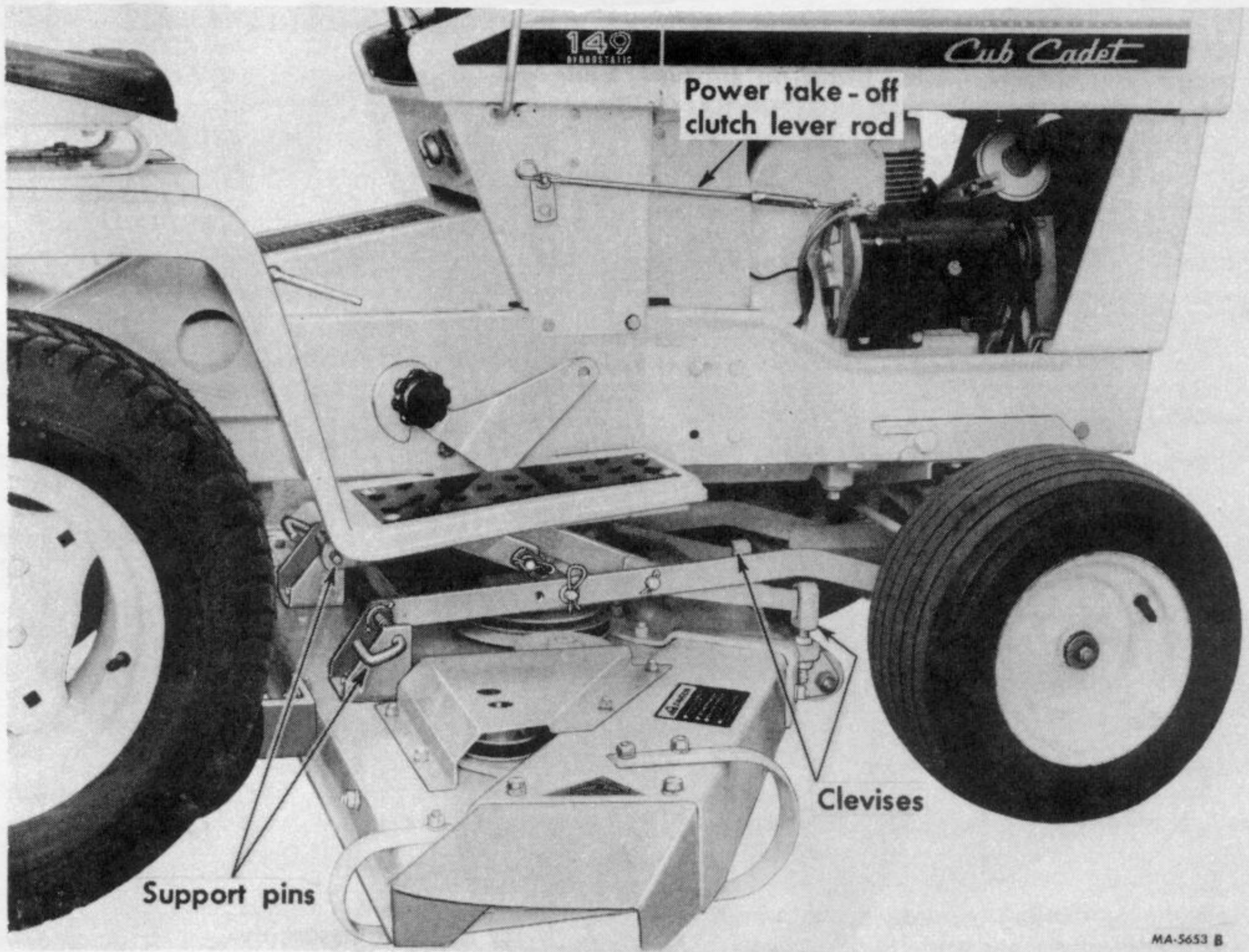

1. Raise the lift frame and turn the front wheels to the right.
2. Slide the mower under the tractor from the right until centered.
3. Lower the lift frame.
4. Raise the front of the mower and slide back to slip clevises over pivot links.
5. Release support pins and connect into lift linkage arms.

If the spring loaded support pins do not line up with holes in the lift frame, loosen bolts holding the support pin brackets to the mower housing. This will align the pins with the holes in the lift frame to mount the mower. After mounting, retighten the bolts.

Refer to the ADJUSTING AND OPERATING under "Level Adjustment", "Height of Cut", and "V-Belt Adjustment" for the necessary adjustments.

SETTING UP

STEP 1. GAUGE WHEELS, BRACKETS, DEFLECTOR SHIELD, MOWER BELT COVER, AND SUPPORT CLEAVISES

44 AND 50-INCH MOWER

44 AND 50-INCH MOWER (50-INCH SHOWN)

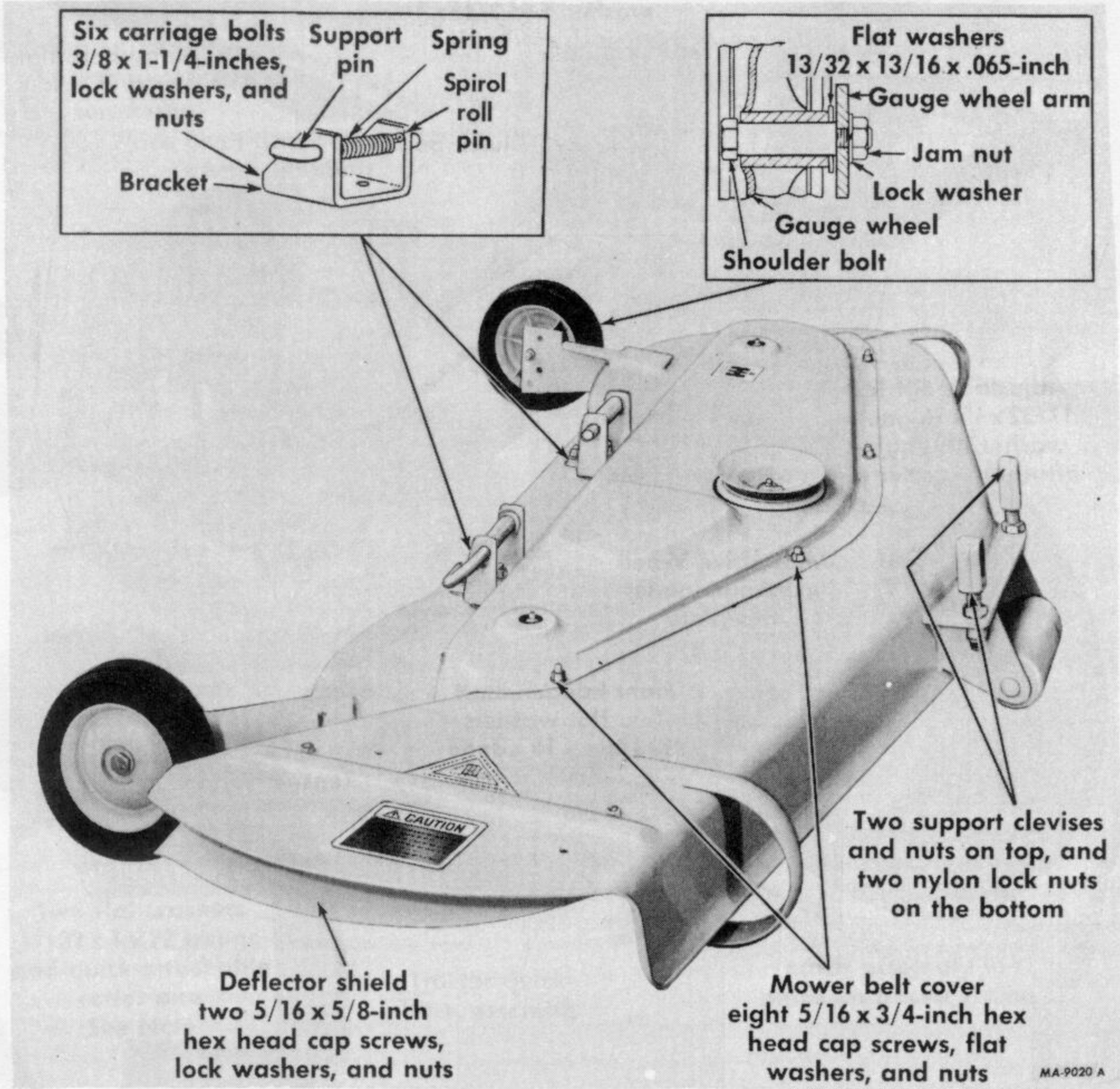

NOTE: Set the tractor lift in the lowest position before connecting the lift links to the tractor lift arms.
NOTE: The 44-inch mower belt cover requires only seven cap screws.

SETTING UP

STEP 2. LIFT FRAME AND FRONT HANGER ASSEMBLY

44 AND 50-INCH MOWER

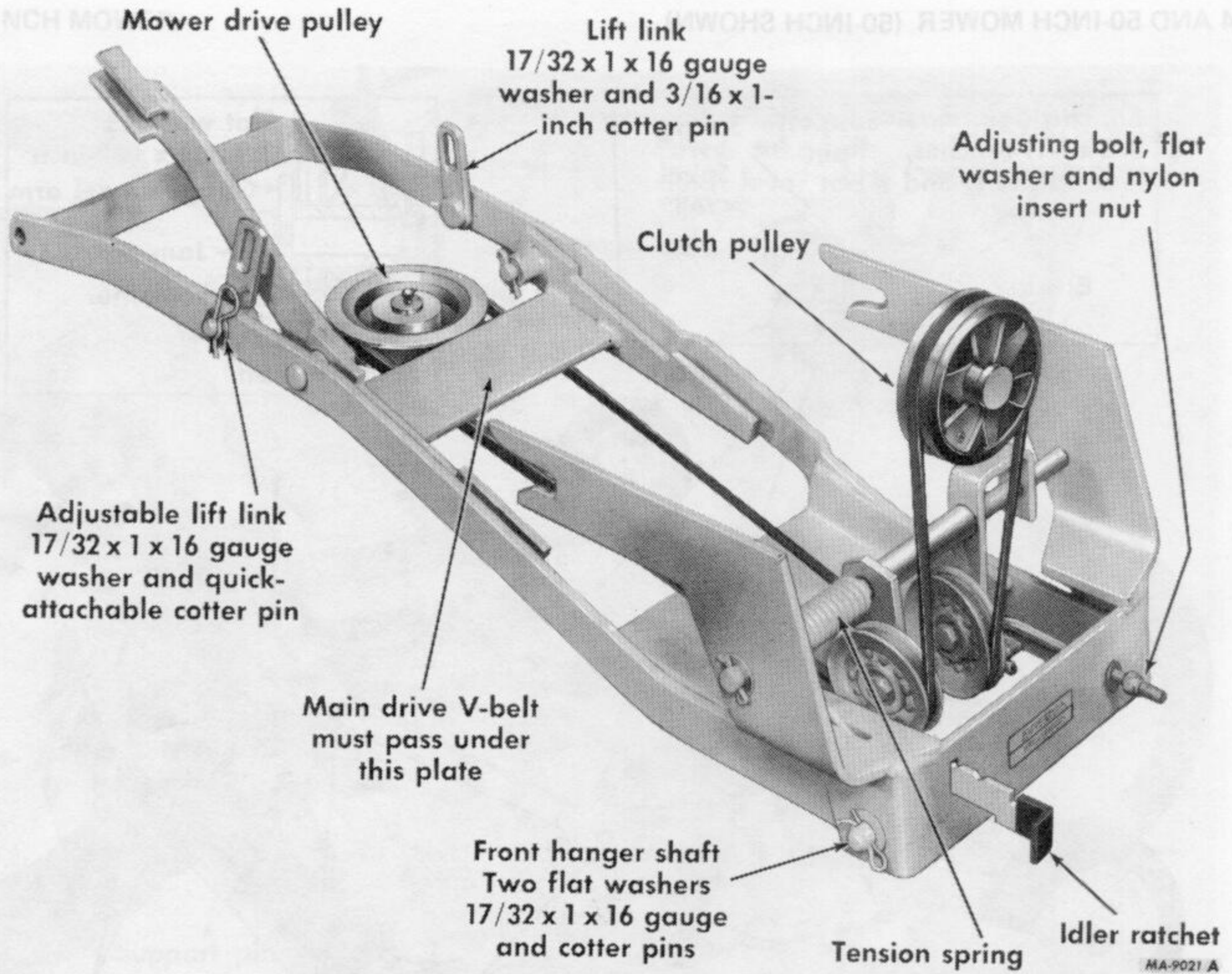

Two support clevises
one nut on top, and
two nylon lock washers
on the bottom.
Cover the lift frame.
Slide the front hanger
and adjust the front
hanger. The front hanger
cover is shown in
figure 2-16 x 2-16 inch
eight 2-16 x 3/4-inch hex
the front hanger and
to slide the front hanger
mount the mower. After mounting, retighten the bolts.

Refer to the ADJUSTING AND OPERATING under "Level Adjustment", "Height of Cut", and "V-Belt Adjustment" for the necessary adjustments.

NOTE: The 44-inch mower belt cover requires only seven adjustments.

SETTING UP

STEP 3. ATTACHING LIFT FRAME ASSEMBLY TO TRACTOR

44 AND 50-INCH MOWER

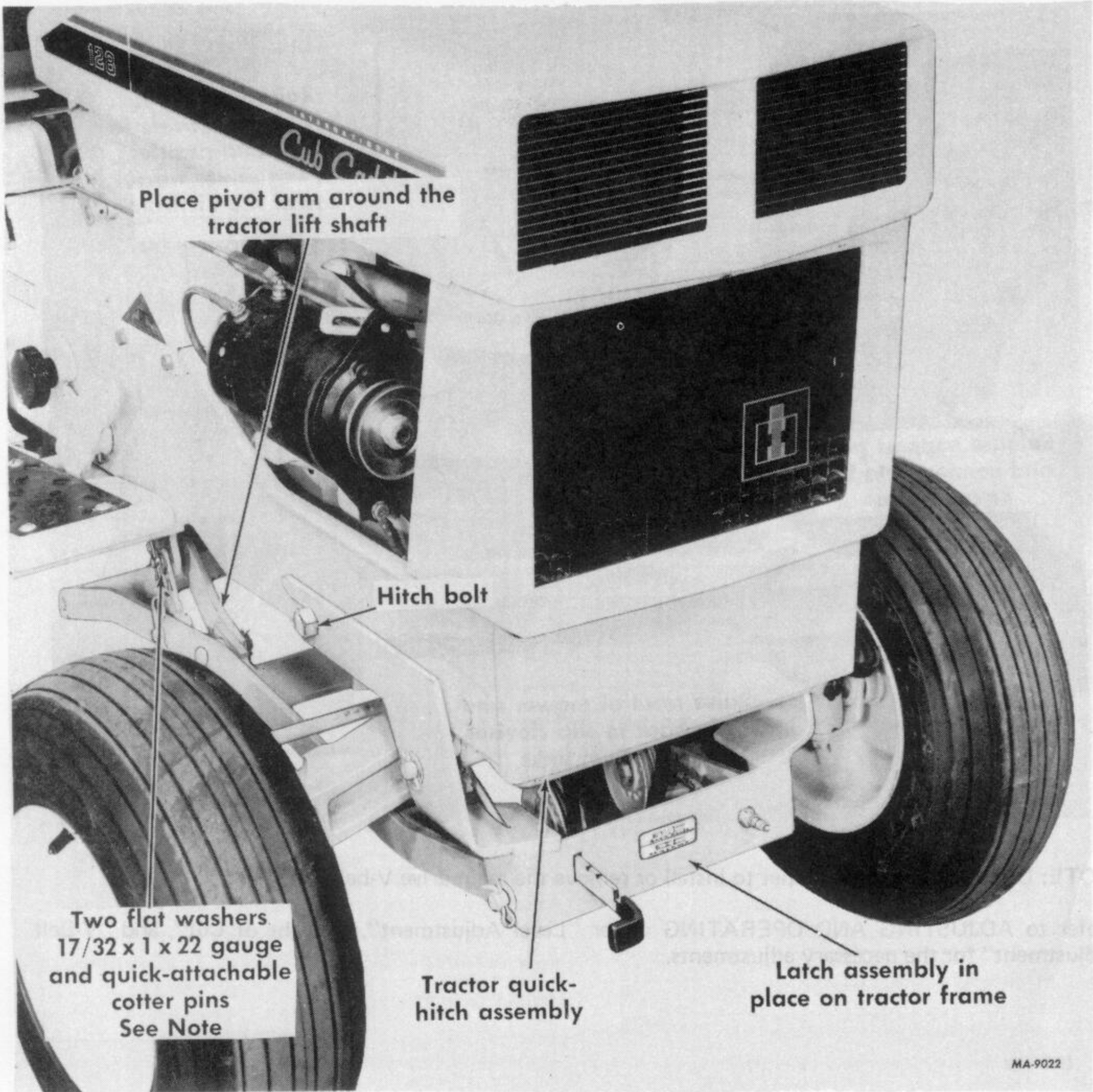

MA-9022

NOTE: Set the tractor lift in the lowest position before connecting the lift links to the tractor lift arms.

Accidents can be prevented with your help

No accident-prevention program can be successful without the wholehearted co-operation of the person who is directly responsible for the operation of equipment.

To read accident reports from all over the country is to be convinced that a large number of accidents can be prevented only by the operator anticipating the result before the accident is caused and doing something about it. No power-driven equipment, whether it be transportation or processing, whether it be on the highway, in the harvest field or in the

industrial plant, can be safer than the man who is at the controls. If accidents are to be prevented—and they can be prevented—it will be done by the operators who accept a full measure of their responsibility.

It is true that the designer, the manufacturer, the safety engineer can help; and they will help, but their combined efforts can be wiped out by a single careless act of the operator.

It is said that "*the best kind of a safety device is a careful operator.*" We ask you to be that kind of an operator.

