

**INTERNATIONAL®
CUB CADET®
982
TRACTOR**

INTERNATIONAL®

OPERATOR'S MANUAL



To The Owner

Assembled in this manual are operation, lubrication, and maintenance instructions for the Cub Cadet 982 Tractors. The material has been prepared in detail to help you better understand the correct care and efficient operation of your tractor. Before you operate the tractor, study this manual carefully. Additional copies may be ordered from your dealer at a nominal price.

Your local authorized dealer is interested in the performance you receive from this tractor. He has factory-trained servicemen, informed in the latest method of servicing tractors, modern tools, and original-equipment service parts which assure proper fit and good performance.

The Cub Cadet 982 Tractor has a hydrostatic drive. It is the best hydrostatic drive unit available and will require minimum service if recommended operation and maintenance procedures are followed.

To obtain top performance and assure economical operation, the tractor should be inspected, depending on its use, periodically, or at least once a year, by your authorized dealer.

When in need of parts, always specify the model, chassis, and engine serial numbers including the prefix and suffix letters. Write these serial numbers in the space provided on page 3.

Should you desire additional information not found in this manual, contact your authorized dealer. **UNDER NO CIRCUMSTANCES SHOULD YOU ATTEMPT TO SERVICE THIS UNIT YOURSELF.** Only your dealer is authorized to repair or replace units on this drive under the terms of the warranty. Should you desire additional information not found in this manual, contact your authorized dealer.



MA-17532

CONTENTS

TO THE OWNER	1	HITCHING EQUIPMENT	
SERIAL NUMBERS	3	TO THE TRACTOR	20 to 22
INTRODUCTION	3	Three-Point Hitch (Optional)	20
SAFE OPERATION PRACTICES	4, 5	Lift Link Adjustments	21
INSTRUMENTS AND CONTROLS	6	Upper Link Adjustment	21
BEFORE OPERATING YOUR TRACTOR	7	Cam Sway Limiter Plates	21, 22
OPERATING THE TRACTOR	7 to 11	Coupling the Equipment to the Three-Point Hitch	22
Governor	7	Uncoupling the Implement	22
Throttle Lever	7	Drawbar	22
Speed Control Lever	7	REAR POWER TAKE-OFF (OPTIONAL)	22, 23
Speed Control Lever Stop	8	Operating the Rear Power Take-Off Clutch	22
Starting the Engine	8	Adjusting the Power Take-Off Clutch	22, 23
Tractor Break-In Procedure	8	Attaching Equipment to Power Take-Off Shaft	23
Stopping the Engine	8	FRONT POWER TAKE-OFF	23
Cold Weather Starting	8, 9	Operating the Front Power Take-Off Clutch	23
Operating in Cold Weather	9	Adjusting the Power Take-Off Clutch	23
Hood and Noise Isolation Panels	9	BRAKES	23, 24
Adjusting the Seat	9	Operating the Standard Brake	23
Neutral Pedal	9, 10	Operating the Dual Brake Pedals	24
Applying the Parking Brake	10	Dual Brake Adjustment	24
Dual Brake Pedals	10	FRONT WHEELS	25
Dual Brake Pedal Lock	10	Front Wheel Toe-In	25
Driving the Tractor	10, 11	Turning Radius	25
Driving on Slopes	11	PNEUMATIC TIRES	25, 26
Stopping the Tractor	11	Inflation	25
ENGINE AND FUEL SYSTEM	12 to 16	Operating Pressure for Tires	25
Engine Oil	13	Care of Tires	25, 26
Engine Oil Filter	13, 14	Rear Wheel Weights (Optional)	26
Fuel Shut-Off Valve	14	Mounting Tires on the Rim	26
Hydrostatic Drive		Tire Chains (Optional)	26
Hydraulic Fluid Filter	14	Overloading	26
Carburetor Adjustments	14 to 16	Seat Maintenance	26
ENGINE COOLING AND AIR CLEANER	16	STORING THE TRACTOR	26, 27
Engine Cooling	16	Removing from Storage	27
Dry Type Air Cleaner with Foam Pre-Cleaner Element	16, 17	OPTIONAL EQUIPMENT AND ACCESSORIES	27
ELECTRICAL SYSTEM	17 to 19	MAINTENANCE CHART	28
Safety Starting Switch	17	TROUBLE SHOOTING	29, 30
Seat Safety Switch	17	LUBRICATION TABLE	31
Charge Indicator	17	LUBRICATION GUIDE	32 to 35
Hour Meter	17	SPECIFICATIONS	36 to 38
Combination Lights and Ignition Switch	17, 18	METRIC (SI) MEASUREMENTS	39
Spark Plugs	18		
Fuses	18		
Battery	18, 19		
HYDRAULIC LIFT	19, 20		
Operating Instructions	19, 20		

WARNING: TO PURCHASERS OF INTERNAL COMBUSTION ENGINE EQUIPPED MACHINERY OR DEVICES IN THE STATE OF CALIFORNIA

The equipment which you have just purchased does not have a spark arrester. If this equipment is used on any forest covered land, brush covered land, or grass covered unimproved land in the State of California, before using on such land, the California law requires that a spark arrester be provided. In addition, spark arrester is required by law to be in effective working order. The spark arrester must be attached to the exhaust system and comply with Section 4442 of the California Public Resources Code.

SERIAL NUMBER LOCATION

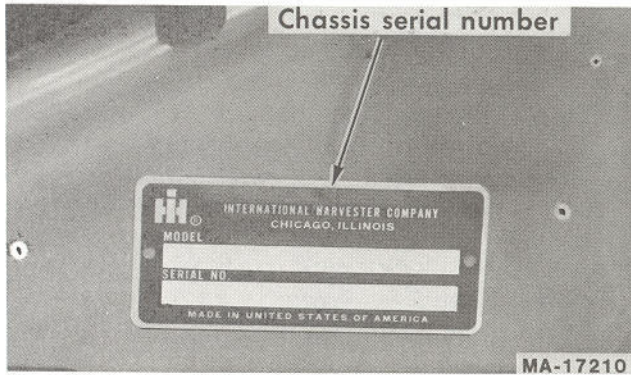

Serial number plate is located near left rear fender.

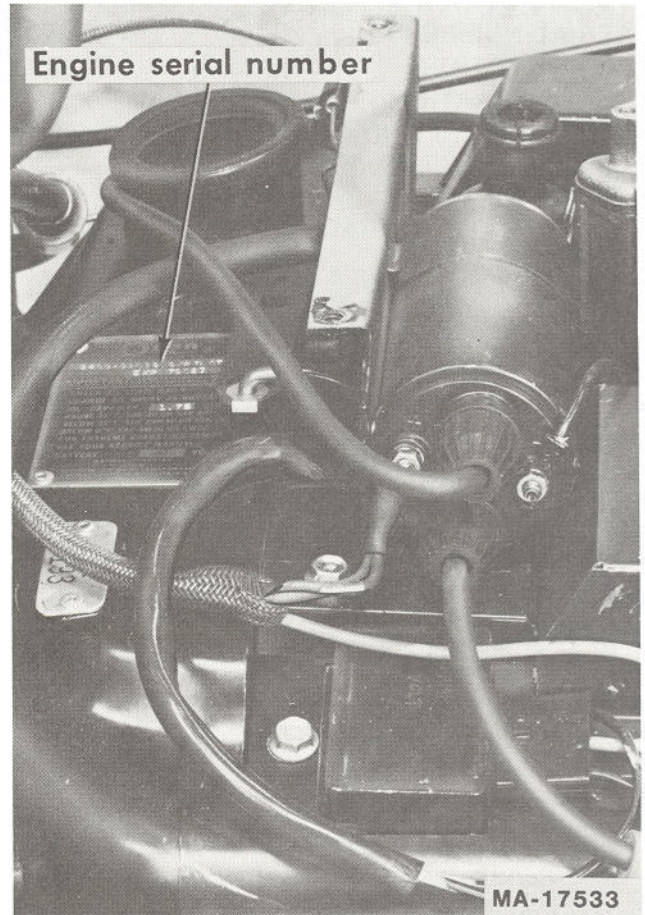

MODEL _____

DELIVERY
DATE _____

INTRODUCTION

A variety of extra equipment and accessories is available. Where operating and maintaining instruction is required, it is included in the instruction for operating and maintaining the tractor. Disregard the instructions for equipment not on your tractor.

LEFT and RIGHT indicate the left and right sides of the tractor when facing forward in the driver's seat. Reference to FRONT indicates the grille end of the tractor; to REAR the drawbar end.



CAUTION

To reduce the potential for any injury, comply with the following safety instructions. Failure to comply with the instructions may result in personal injury.

SAFE OPERATION PRACTICES FOR RIDING VEHICLES

1. It is suggested that this manual be read in its entirety before attempting to assemble or operate this unit. Keep this manual in a safe place for future reference and for ordering replacement parts.
2. This unit is a precision piece of power equipment, not a plaything. Therefore exercise extreme caution at all times.
3. Know the controls and how to stop quickly—**READ THIS OWNER'S MANUAL.**
4. Do not allow children to operate vehicle. Do not allow adults to operate it without proper instruction. Only persons well acquainted with these rules of safe operation should be allowed to use your mower.
5. No one should operate this unit while intoxicated or while taking medication that impairs the senses or reactions.
6. Wear sturdy, rough-soled work shoes and close-fitting slacks and shirts to avoid entanglement in the moving parts. Never operate a tractor in bare feet, sandals, or sneakers.
7. To prevent injury, do not carry passengers or give rides. (Keep children, pets and bystanders out of the area while mowing.) Only the operator should ride on the unit and only in the seat.
8. Check overhead clearance carefully before driving under power lines, guy wires, bridges, low hanging tree branches, entering or leaving buildings, or other situations where the operator may be struck or pulled from the tractor which could result in serious injury.
9. To maintain control of the tractor and reduce the possibility of upset or collision operate the tractor smoothly—avoid erratic operation and excessive speed.
10. Keep the area of operation clear of all persons, particularly small children and pets. Stop engine when they are in the vicinity of your mower. Although the area of operation should be completely cleared of foreign objects, a small object may have been overlooked and could be accidentally thrown by the mower in any direction and cause injury.
11. Clear work area of objects which might be picked up and thrown by the mower in any direction and cause injury.
12. Stop the blade(s) when crossing gravel drives, walks or roads.
13. Disengage all attachment clutches and shift into neutral before attempting to start engine.
14. Disengage power to attachment(s) and stop engine before leaving operating position.
15. Do not put hands or feet near or under rotating parts. Keep clear of the discharge opening at all times as the rotating blade(s) can cause injury.
16. Disengage power to attachment(s) and stop engine before making any repairs or adjustments. Disconnect the spark plug wire and keep the wire away from the plug to prevent accidental starting.
17. Before attempting to unclog the mower or discharge chute, stop the engine. The mower blade(s) may continue to rotate for a few seconds after the engine is shut off. Therefore, be sure the blade(s) have stopped completely. Disconnect the spark plug wire and keep the wire away from the plug to prevent accidental starting.
18. Disengage power to attachment(s) when transporting or not in use.
19. Take all possible precautions when leaving vehicle unattended such as disengaging power-take-off, lowering attachments, shifting into neutral, setting parking brake, stopping engine and removing key.
20. Do not stop or start suddenly when going uphill or downhill. Mow up and down face of steep slopes; never across the face.
21. Reduce speed on slopes and in sharp turns to prevent tipping or loss of control. Always keep the tractor in gear when going down steep hills to take advantage of engine braking action.
22. Stay alert for holes in terrain and other hidden hazards.
23. Use care when pulling loads or using heavy equipment.
 - A. Use only approved drawbar hitch points.
 - B. Limit loads to those you can safely control.
 - C. Do not turn sharply. Use care when backing.
 - D. Use counterweight(s) or wheel weights when suggested in owner's manual.
24. Watch out for traffic when crossing or near roadways.
25. When using any attachments, never direct discharge of material toward bystanders nor allow anyone near vehicle while in operation.
26. Handle gasoline with care. It is highly flammable.
 - A. Use approved gasoline container.
 - B. Never remove cap or add gasoline to a running or hot engine or fill fuel tank indoors. Wipe up spilled gasoline.
 - C. Open doors if engine is run in garage. Exhaust fumes are dangerous. Do not run engine indoors.
27. Keep the vehicle and attachments in good operating condition, and keep safety devices in place. Use guards as instructed in owner's manual.

28. Keep all nuts, bolts, and screws tight to be sure the equipment is in safe working condition.
29. Never store the equipment with gasoline in the tank inside a building where fumes may reach an open flame or spark. Allow engine to cool before storing in any enclosure.
30. To reduce fire hazard, keep engine free of grass, leaves or excessive grease.
31. The vehicle and attachments should be stopped and inspected for damage after striking a foreign object. The damage should be repaired before restarting and operating the equipment.
32. Do not change the engine governor settings or overspeed the engine.
33. When using the vehicle with mower, proceed as follows:
 - (1) Mow only in daylight or in good artificial light.
 - (2) Never make a cutting height adjustment while engine is running if operator must dismount to do so.
- (3) Shut the engine off and wait until the blade comes to a complete stop before removing the grass catcher.
- (4) Check blade mounting bolts for proper tightness at frequent intervals.
34. Check grass catcher bags frequently for wear or deterioration. For safety protection, replace only with new bag meeting original equipment specifications.
35. Look behind to make sure the area is clear before placing the transmission in reverse and continue looking behind while backing up.
36. Whenever possible, avoid driving the tractor on an incline such as a ramp or slope. If necessary to move the tractor on an incline, whenever practical back the tractor up the incline and drive the tractor forward down the incline. Use extreme caution if it is necessary to drive the tractor up an incline or back the tractor down an incline because the front of the tractor could lift and rapidly flip over backward which could cause serious injury.

ENERGY CONSERVATION FOLLOW THESE RECOMMENDATIONS



**An Energy Conservation Plan is your best insurance
against waste. Energy is Money. Don't Waste It!!**

An Energy Conservation Plan consists of:

1. Being sure the equipment is properly adjusted to the task being performed. Review Operator's Manual thoroughly.
2. Being sure the operator is thoroughly trained in the operation of the equipment. Review Operator's Manual thoroughly.
3. Being sure that proper lubrication and maintenance procedures are followed. Review Operator's Manual thoroughly.
4. Matching as closely as possible the tractor size (horsepower) to the implement size and soil conditions.
5. Make sure the engine is properly adjusted. This includes:
 - A. Proper carburetor adjustment.
 - B. Fuel and air filter servicing at the proper intervals.
 - C. Check air gap of the ignition points and spark plugs.
6. Use the proper lubricants and fuel for the particular season of the year the tractor is being operated.
7. Do not overfill the fuel tank.
8. Do not idle the engine for long periods of time.
9. Make sure the tires are inflated properly. Refer to "Tires" for various inflation pressures.
10. Many tractor operations do not require full load operation. Whenever possible shift to a higher gear and throttle back to increase fuel economy.
11. Excessive ballast is wasteful of fuel. Use only enough ballast to insure stability and traction for the job being performed.
12. Make the minimum number of passes over the field.
13. Maintain sharp mower blades.
14. Level the mower properly.
15. Keep the underside of the mower deck clean.

INSTRUMENTS AND CONTROLS

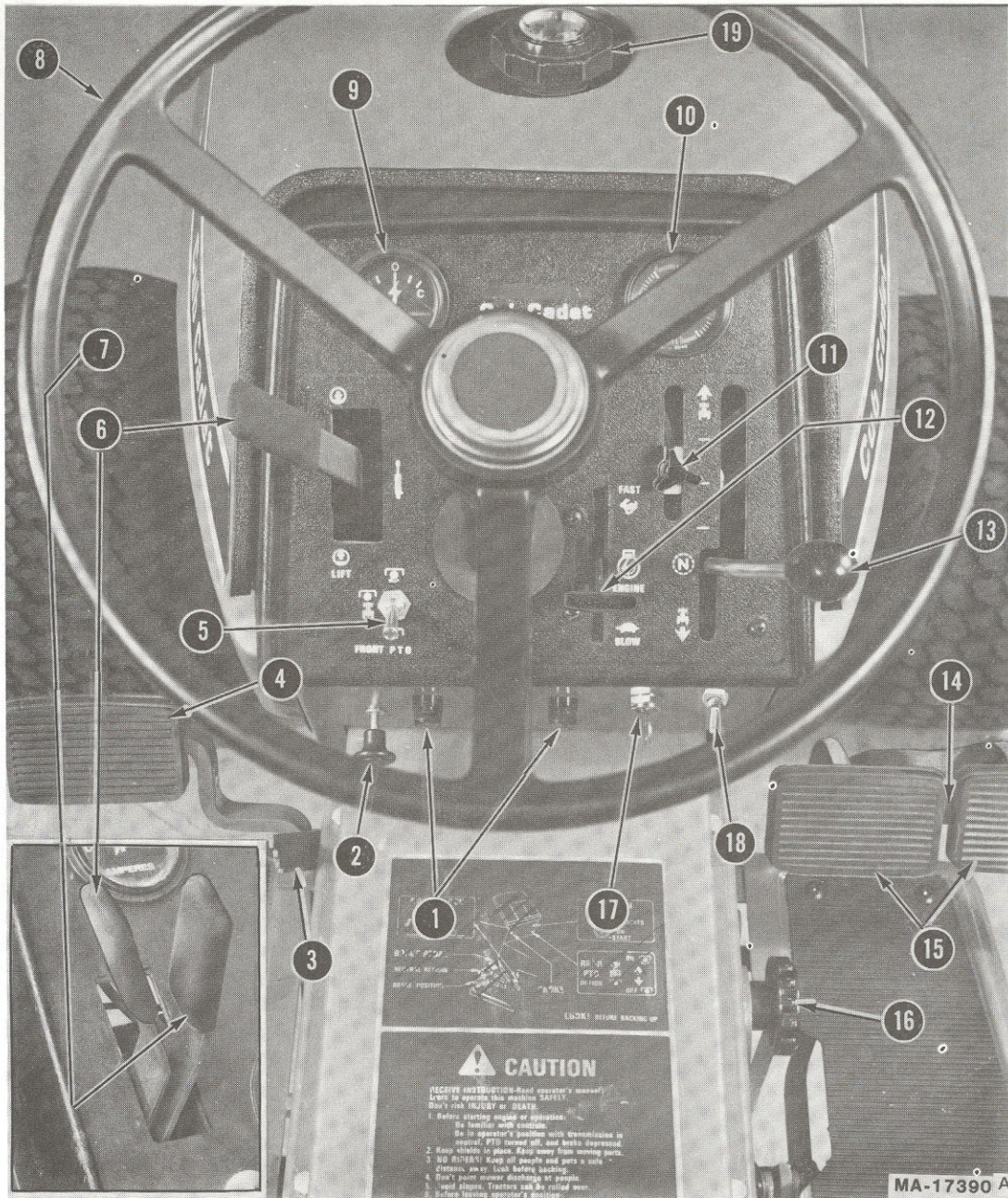

- | | |
|---|---|
| 1. Fuses | 11. Speed control lever stop |
| 2. Choke control | 12. Throttle lever |
| 3. Brake pedal lock | 13. Speed control lever |
| 4. Neutral return pedal | 14. Dual brake pedal lock |
| 5. Front power take-off control switch | 15. Dual brake pedals |
| 6. Hydraulic lift control lever
(See inset) | 16. Cam lock knob |
| 7. Hydraulic front power
outlet control lever* (See inset) | 17. Combination lights and
ignition switch |
| 8. Steering wheel | 18. Rear power take-off
control switch* |
| 9. Charge indicator | 19. Fuel tank filler cap
and gauge |
| 10. Hour meter | |

*Optional Equipment

BEFORE OPERATING YOUR TRACTOR

Before you operate the tractor study this manual carefully. It has been prepared to help you operate and maintain your tractor with utmost efficiency. Familiarize yourself with the operation of all the instruments and controls.

Fill the fuel tank.

Check the engine and transmission oil level.

Clean the air cleaner element if necessary.

Check the tire inflation pressures.

Adjust the seat for operator's maximum comfort, visibility, and complete control of the tractor.

Refer to various sections of the operator's manual for additional information.



WARNING

To prevent injury, do not carry passengers or give rides. Keep children, pets and bystanders a safe distance away.

OPERATING THE TRACTOR



CAUTION

1. Keep all shields in place.
2. Before leaving operator's position:
 - a. Shift transmission to neutral
 - b. Set parking brake
 - c. Disengage attachment clutch
 - d. Shut off engine
 - e. Remove ignition key
3. Wait for all movement to stop before servicing machine.
4. Keep people and pets a safe distance away from machine.
5. Look to the rear before backing up.



DANGER

DO NOT OPERATE MOWER UNLESS GUARD OR ENTIRE GRASS CATCHER IS IN ITS PROPER PLACE.

GOVERNOR

The governor is set at the time the engine is assembled and should not require readjustment unless the governor arm is removed or loosened from the governor shaft. Consult your authorized dealer if the governor does not function properly.

THROTTLE LEVER

This lever controls the speed of the engine. When set in a given position, it will maintain a uniform engine speed.

When using power take-off operated equipment, best performance is achieved with the throttle lever in the "FAST" position. Refer to "Instruments and Controls."



This symbol shows fast position.



This symbol shows slow position.

SPEED CONTROL LEVER

The lever is used to select any speed from a standstill "N" position to eight miles per hour in the forward direction and to four miles per hour in the reverse direction.

Moving the speed control lever forward provides increased forward speed, and moving the lever rearward provides the reverse speeds. Refer to "Instruments and Controls."

NOTE:

Do not rest your foot on the neutral return pedal while driving the tractor as this would cause the speed control lever to return to the "N" position.

SPEED CONTROL LEVER STOP

An adjustable speed control lever stop is provided to allow the operator to return to a predetermined speed.

STARTING THE ENGINE

1. Be sure there is an adequate supply of fuel in the tank.



WARNING

To avoid fire or injury, tighten fuel cap securely. Never remove the fuel tank cap or fill the fuel tank when the engine is running, or hot, or indoors. Also, do not smoke when working around flammable fuel.

2. Be sure the fuel shut-off valve is open.
3. Pull choke control button to full choke position. Less choking may be necessary due to variations in temperature, grade of fuel, etc. Little or no choking will be needed when the engine is warm.
4. Place the throttle just off "SLOW" position.
5. To start the engine, safety starting switches must be activated by pressing the neutral return pedal all the way down and moving the power take-off clutch switch to the disengaged position.

NOTE:

The speed control lever will return to neutral when the neutral return pedal is pressed all the way down.

6. Turn the ignition key clockwise to the "START" position and release it as soon as the engine starts; however do not operate the starter for more than 30 seconds at any one time. If the engine does not start within this time, turn the key "OFF" and wait a few minutes, then try again.
7. After the engine starts, slowly release the brake pedal and gradually push the choke control button all the way in. Do not use the choke to enrich the fuel mixture, except as necessary to start the engine.

IMPORTANT:

After striking a foreign object, stop the engine. Remove wire from spark plug, thoroughly inspect the mower for any damage, and repair the damage before restarting and operating the mower.

TRACTOR BREAK-IN PROCEDURE

Never operate a new engine immediately under full load. Break it in carefully as shown in the table below.

Period	Engine Throttle Control Lever Position			Load
	1/2	3/4	Full	
1st hour		X		None
2nd hour	X			Light drawbar load
			X	Mowing with tractor at slow speed
3rd through 13th hour		X		Medium drawbar load
			X	Normal mowing

STOPPING THE ENGINE

Move the throttle lever to the "SLOW" position and allow the engine to idle for a short time before stopping. Then turn the key to the "OFF" position.

COLD WEATHER STARTING

To start engine in cold weather use correct weight of engine oil, be sure battery is fully charged, and the proper starting procedure is followed. The best procedure for starting at temperatures near or below freezing is as follows:

1. Pull the choke all the way out into the full choke position.
2. Place the throttle lever just off "SLOW" position.
3. Press the neutral return pedal all the way down and be sure the power take-off switch is in the off position. The safety interlocks will prevent starting unless this is done. If tractor is equipped with rear power take-off, be sure both switches are in the off position.
4. Move the key switch into the start position and hold until the engine starts; however, do not operate the starter for more than 30 seconds at any one time. As soon as the engine starts, slowly push the choke in part way.



WARNING

During operation do not run the engine in confined area such as storage building any longer than is necessary. Immediately move the tractor outside into the air.

NOTE:

In cold weather the starting motor may disengage prematurely. This is caused by the engine firing once but failing to continue running. If this happens several times, the engine will be flooded and it will be necessary leave the throttle in the slow position but push the choke in all the way; then turn the ignition key to the start position and slowly pull the choke out to the position which will cause the engine to start and continue running. If the engine falters after putting tractor into motion, pull the choke out part way until the engine runs smoothly, then gradually push the choke back in as the engine warms.

OPERATING IN COLD WEATHER

While operating this tractor equipped with a 19.9 HP 2 cylinder engine, at light loads and usually in low temperature conditions, it is possible to foul out a spark plug. This will result in gasoline entering the crankcase by way of the piston rings on the cylinder which is not firing.

Some symptoms are:

1. Oil level will rise due to gasoline in crankcase.
2. Air filter becomes oil and fuel soaked.
3. Engine leaks oil.
4. Mis-firing.

This condition does not necessarily mean that the carburetor, piston rings, ignition coil-wires-points, or gaskets are defective.

Correction:

1. Replace both spark plugs.
2. Check air filter element, replace if needed.
3. Change oil.
4. Adjust carburetor if needed.
5. Service spark plugs regularly when using tractor under light duty or low temperature conditions.

HOOD AND NOISE ISOLATION PANELS

The tractor hood is arranged to swing up and forward for easy access to the engine compartment. The hood locks automatically when raised. To lower hood, release latch on left side by gently pushing hood up to release tension and pull latch to left. Also, whenever engine maintenance is required, the noise isolation panels can be readily removed by removing the two wing nuts (one on each side) and disconnecting the panel spring.

ADJUSTING THE SEAT

Before starting the tractor, adjust the seat to the most comfortable driving position. Tilt the seat forward over the steering wheel, loosen the four cap screws in the seat support, and slide the seat assembly forward or rearward to the position which is most comfortable for the operator.

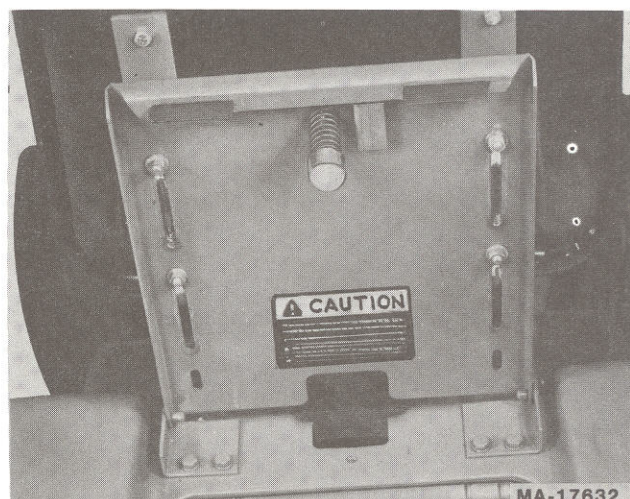

Retighten the cap screws after the seat is adjusted.

NOTE:

The battery is located in a well under the operator's seat for ease in servicing or replacement when necessary.

NEUTRAL PEDAL

When the neutral pedal is depressed all the way down, it activates the safety start switch and automatically moves the speed control lever to the "N" position and returns the transmission to neutral. It also applies the left wheel brake if the brake pedals are not locked together and both wheel brakes if the brake pedals are locked together.

The tractor should be stopped either by simultaneously depressing the neutral pedal and both brake pedals or by manually returning the speed control lever to neutral while depressing both brake pedals.

For brake adjustments, refer to “**Brake**” section of manual.

APPLYING THE PARKING BRAKE

Always lock the brake when the tractor is parked on a grade. To lock the brake, brake pedals must be latched together to provide braking to both rear wheels. Latch dual brake pedals together, depress neutral pedal (left side), place the pedal lock in the engaged position. Refer to “**Dual Brake Pedals.**”

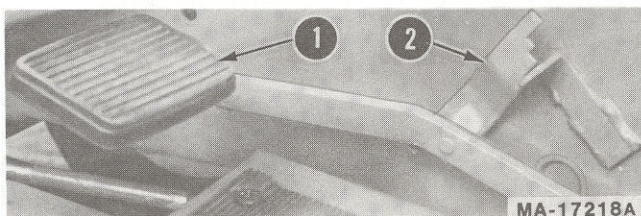

1. Neutral pedal
2. Parking brake pedal lock

Parking brake in the engaged position.



WARNING

The hydrostatic transmission will not hold the tractor on a hill. In a short period of time (depending on the hill) the oil will drain from the transmission and allow the tractor to roll down hill. To avoid an accident and/or possible injury, lock the brake.

DUAL BRAKE PEDALS

Two brake pedals are used for individual braking of the rear wheels to aid in turning the tractor in soft soil conditions. Depress the right brake pedal to slow or stop the right rear tractor wheel, depress the left brake pedal to slow or stop the left rear tractor wheel. The tractor will turn in the direction of the wheel that is slowed or stopped. For brake adjustments, refer to “**Brake**” section of manual.

DUAL BRAKE PEDAL LOCK

The brake pedal lock is located in the top edge of the right brake pedal and is used to lock the two pedals together to provide simultaneous braking to both rear wheels when the brake pedals are

depressed. To lock the pedals together, pivot the lock and engage it in the slot in the left pedal. For individual brake action, pivot the lock into the storage slot in the right brake pedal.

If the brake pedals are not locked together and the neutral pedal is used, only the left rear tractor wheel is slowed or stopped.



1. Dual brake pedal lock



WARNING

Use the two pedal brakes as turning brakes only at low speeds to maintain control of the tractor when using rear mounted equipment.



WARNING

Pedals must be latched together when operating the tractor in transport speeds.

Individual wheel brakes should not be used when mowing lawns. The wheel being braked may skid and cause lawn damage. Pedal should be latched together to prevent this.

DRIVING THE TRACTOR

1. Depress the neutral pedal, release the brake lock, and let the pedal up. Move the throttle lever to the position where the engine operates best for the load to be handled.
2. Start the tractor in motion by moving the speed control lever slowly forward or rearward to desired speed.

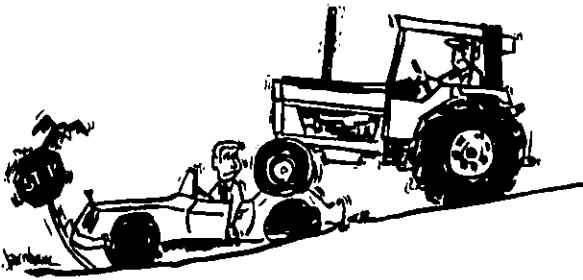

WARNING

Avoid sudden starts, excessive speed, sudden stops. Keep vehicle in gear when going down hills.

NOTE:

When using power take-off operated equipment best performance is achieved with the throttle lever in the "FAST" position.

Unless dual brake pedals are needed for control in turning the tractor, they should be locked together at all times to provide simultaneous braking to both rear wheels.

SEAT SAFETY SWITCH

When using power take-off operated equipment, the operator must remain in tractor seat at all times. If operator should leave tractor seat without turning off the power take-off switch, the engine will automatically shut off.



CAUTION

Do not operate the tractor if the interlock system is malfunctioning because it is a safety device, designed for protection.

DRIVING ON SLOPES

Before operating the tractor on any slope, walk the slope to look for possible hazards such as rocks, mounds, ruts, stumps or other surface irregularities which could cause an upset.

Back the tractor with implement up the steepest portion of each slope you intend to work. If the tractor can not negotiate the slope in reverse, the slope is too steep to be worked.



WARNING

Always drive up or down the face of a slope. Do not drive so that the tractor may tip over sideways.

Avoid turns when driving on a slope. If a turn must be made, turn down the slope. Turning up a slope greatly increases the chance of a roll over.

Avoid stopping when driving up a slope. If it is necessary to stop while driving up a slope, start up smoothly and carefully to reduce the possibility of flipping the tractor over backward.

STOPPING THE TRACTOR

Move the speed control lever to the "N" position and depress the brake pedals. Before dismounting always engage the parking brake and turn the ignition "OFF". Also disengage the power take-off control switch.

Brake pedals must be latched together to provide braking to both rear wheels. Latch dual brake pedals together before locking neutral pedal.

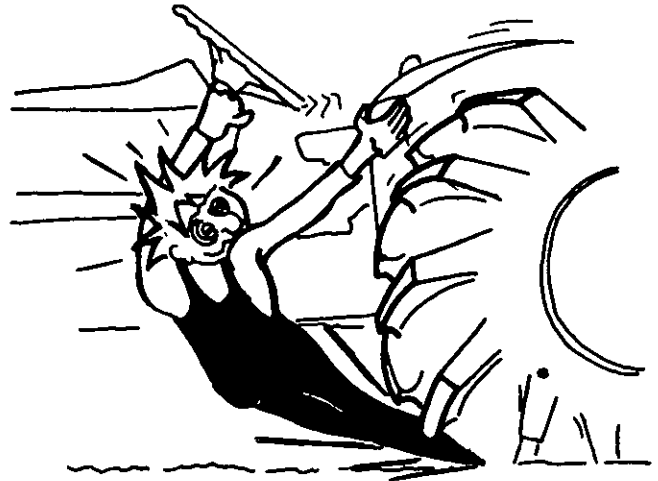

WARNING

Always engage park, lower equipment and shut off engine before dismounting. Never start engine from ground.

ENGINE AND FUEL SYSTEM

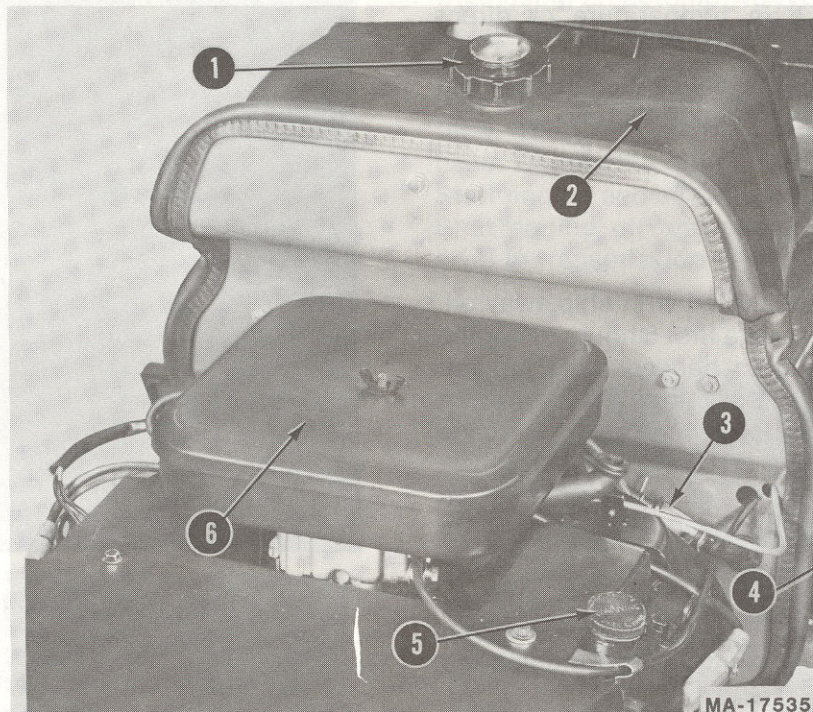

- | | |
|-----------------------------------|---------------------------------------|
| 1. Fuel tank filler cap and gauge | 5. Oil filler cap and engine dipstick |
| 2. Fuel tank | 6. Air cleaner |
| 3. Fuel line and filter | |
| 4. Fuel shut-off valve (not seen) | |

Fuel System

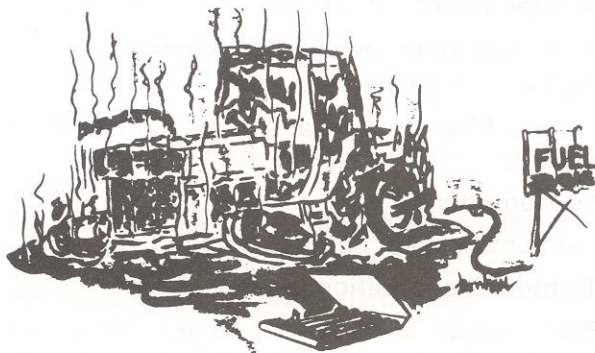

WARNING

NEVER SMOKE while refueling. Shut off engine and electrical equipment.

This engine is designed to operate on unleaded or leaded gasoline with a 91 minimum octane rating (Research Method), or a minimum Antiknock Index (RON + MON)/2 of 87. Antiknock Index is posted on dispensing pumps.

NOTE:

Gasohol is not approved for use by the engine manufacturer and should not be used. The use of gasohol may damage the engine.

The use of unleaded gasoline will increase spark plug and valve life, maintain engine performance longer, and reduce rust and corrosion of the engine while stored.

The fuel tank filler cap has an air vent. Keep the vent open at all times to assure proper flow of the fuel.

Use clean fuel and keep it clean. Store fuel in tanks equipped with hose and nozzle to prevent contamination of the fuel. The use of funnels, cans and drums is not recommended because they are difficult to keep clean.

Allow space for fuel expansion when adding fuel to the tank. A tank filled to capacity may overflow if exposed to a rise in temperature or direct sunlight.

Before starting the engine, check the fuel tank cap to be certain it is tightened completely.

ENGINE OIL

The engine crankcase is filled with ship-away oil. This oil may be used for the first 5 hours of engine operation at temperatures between +90°F. and 0°F. (32°C. and -22°C.). If temperatures are not within this range, drain the oil from the crankcase and replace with new oil as specified in the "Lubrication Table." The engine oil must be drained and replaced with new oil every 50 hours of engine operation.

To aid starting, the selection of crankcase lubricating oils should be based on the lowest anticipated temperatures until the next drain period. Refer to "Lubrication Table."

We recommend IH Low Ash Engine Oil for gasoline engines. IH Low Ash Engine Oil exceeds API Service Classification SE. It is specifically designed for heavy duty service in gasoline engines, and is formulated to minimize metallic deposits, lengthen spark plug and valve life. IH Low Ash Oil used with unleaded gasoline is the ideal combination to maintain performance and extend engine life.

If other than IH Low Ash Engine Oil is used it must meet API Service Classification SE. For maximum engine life select API SE oils with lowest levels of barium, calcium, or magnesium additives and minimum ash content (approximately 0.5%). Lubricant suppliers will normally furnish this information on their engine oils.

Multi-viscosity numbered oils such as SAE 10W-30 or SAE 10W-40 must not be used above 32 degrees Fahrenheit (0 degrees Celsius).

Regularly check the oil level of the engine crankcase to see that it is filled to the correct level.

NOTE:

Check the oil level only while the engine is stopped.

Always keep the oil level between the "FULL" and the "LOW" marks on the dipstick. When checking the oil level the dipstick must be withdrawn and wiped clean, then inserted all the way and withdrawn for a true reading.

ENGINE OIL FILTER

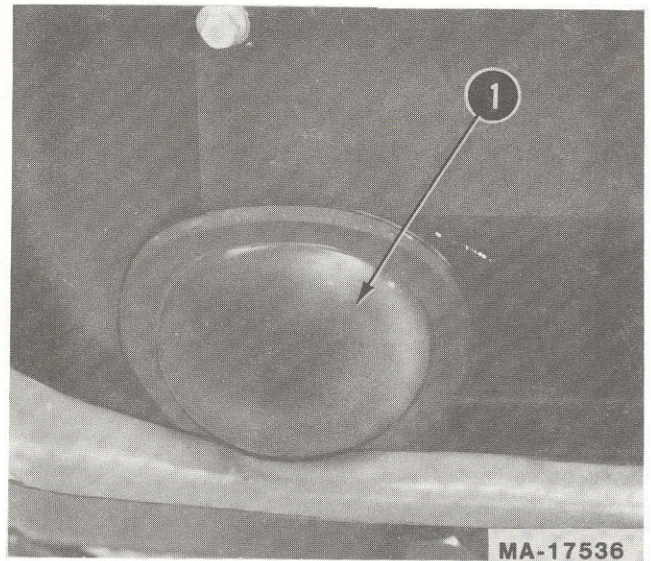

1. Engine oil filter

The life of your engine depends upon clean oil being circulated to all bearings.

The purpose of the oil filter is to separate and remove dirt and other foreign substances from the oil to prevent these injurious materials from being circulated to the engine. Under normal operating conditions, replace filter after the first 50 hours and every 100 hours of operation thereafter.

To remove filter, turn filter counterclockwise using an automotive type filter wrench. Turn filter slowly so oil will drain into drain pan located under filter and not splash back into housing.

To install new filter, proceed as follows:

1. Apply oil to gasket.
2. Thread filter on by hand until tight to seat gasket.
3. Loosen filter.
4. Turn until gasket contacts base.
5. Tighten filter additional one half turn.
6. Start engine and allow it to run for a few minutes. Shut engine off and check for leaks and re-check oil level.

Refer to "Lubrication Table."

Filling the Crankcase

To fill the crankcase with oil, place the tractor on a level surface. Clean the area around oil fill plug before removing.

Remove oil cap and dipstick and fill crankcase to the full mark on dipstick. (Capacity 3.5 pints (1.6L) with filter or 3.2 pts. (1.5L) without filter.) Check oil level on dipstick before adding more oil. Wipe off dipstick before inserting it all the way into the tube, then remove dipstick and check oil level. **DO NOT OVERFILL.** Dipstick must be pushed fully into tube at all times when engine is operating.

NOTE:

Never overfill the engine crankcase. Engine may overheat and/or damage may result if the crankcase is below the "LOW" mark or over the "FULL" mark. For oil capacity refer to the "Specification" and "Lubrication Table" section.

FUEL SHUT-OFF VALVE

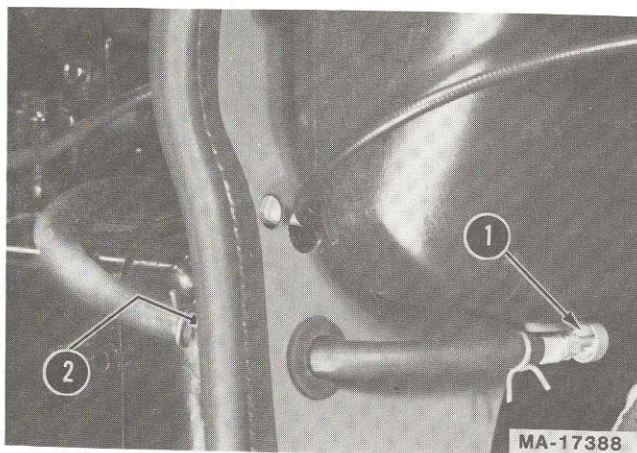

- 1. Fuel shut-off valve
- 2. Fuel filter (not seen)

Be sure the shut-off valve under the fuel tank is open.

To turn the fuel on, turn the knob counterclockwise to the stop.

To turn the fuel off, turn the knob clockwise until it is tight.

HYDROSTATIC DRIVE HYDRAULIC FLUID FILTER

Remove the throw-away can-type filter and replace with a new filter after the first 10 hours and 50 hours of operation, and every 100 hours of operation thereafter.

NOTE:

Clean the outside area before removing the filter to keep dirt from getting into the transmission case. If a mower is mounted on the tractor, the mower must be lowered to facilitate removal of the filter.

To remove the filter, turn the filter counterclockwise using an automotive type filter wrench.

Before installing the new filter, apply a coating of oil on the filter gasket. Thread the filter on by hand until tight enough to seat the gasket. Loosen the filter. Then turn it until the gasket contacts the base. Tighten the filter an additional one half turn. Start engine and allow it to run for a few minutes. Shut engine off and check for leaks, check oil level in transmission case.



Dipstick located in front of seat

CARBURETOR ADJUSTMENTS



If any adjustments are made to the engine while the engine is running (e.g. carburetor), disengage all clutches and blades. Keep clear of all moving parts and be careful of heated surfaces and muffler.



To avoid injury or an accident, be sure the brake pedal is in the locked position, transmission is in neutral, and any equipment is disengaged before starting engine to make carburetor adjustments.

NOTE:

Air cleaner has been removed from illustrations in order to show carburetor.

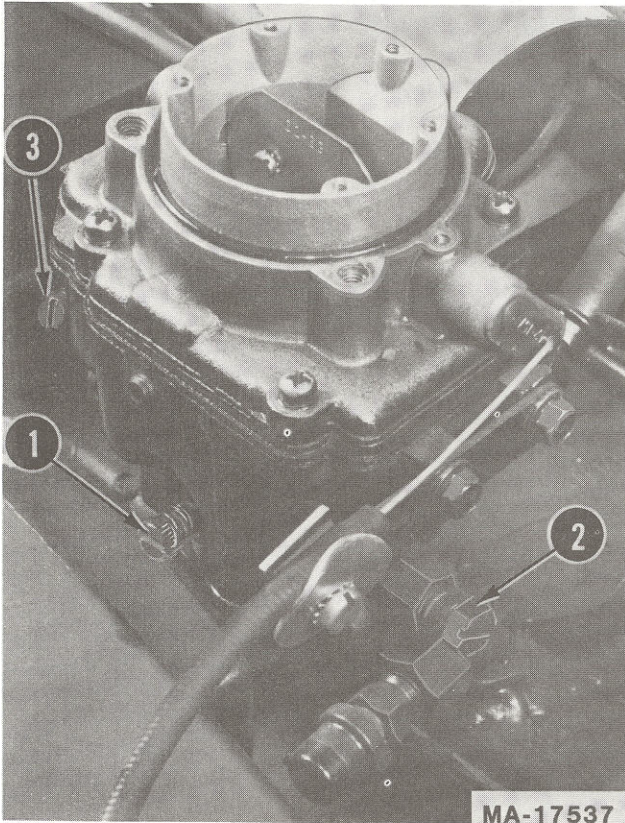

1. Idle fuel adjusting screw
2. Main fuel adjusting screw (High speed)
3. Throttle stop screw

The carburetor idle fuel adjusting screw and main fuel adjusting screws were set for maximum efficiency at the factory and should normally not be disturbed. If adjustments seem necessary, first be sure the ignition system is working properly and is not the source of the problem.

If adjustment is needed, proceed as follows:

1. Turn both mixture adjusting screws in until lightly seated, then back idle fuel adjusting screw out 1-1/8 turns and main fuel adjusting screw out 1-1/2 turns.

NOTE:

Forcing the adjusting screws tight will damage the needle and seat. Turn in only until light tension can be felt.



CAUTION

Exhaust fumes can kill. Never run engine inside buildings.

2. Start engine and allow it to warm up thoroughly (at least 10 minutes).

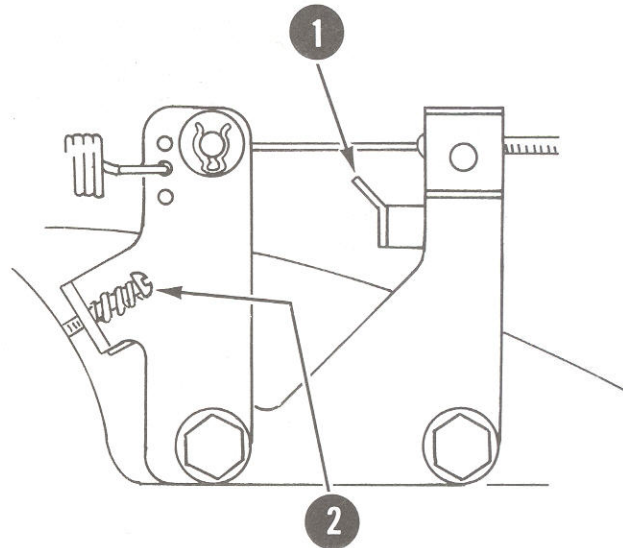

MA-17684

1. High speed governor stop
2. Set low speed adjustment so engine runs at 1,000 RPM in "SLOW" position.
3. Move engine speed control lever to slow position. Back out low speed screw on governor so that throttle stop screw on carburetor controls engine speed. Adjust throttle stop screw for 1,000 r.p.m. idle.

4. Determine best idle mixture setting by first turning idle fuel adjusting screw in until engine speed drops and then outward until engine speed drops again. Over a narrow range between these two settings, engine speed remains at its highest. Set adjustment screw about 1/8 turn outward (rich) from the midpoint of this range.
5. Readjust throttle stop screw for 1,000 RPM idle, then adjust governor low speed screw for 1,200 RPM idle.
6. Move engine speed control lever to fast position. Bend high speed stop on governor so engine runs at vehicle manufacturer's recommended speed, 3,400 r.p.m.
7. Check main mixture adjustment by rapidly accelerating engine from idle to full speed. The engine should accelerate evenly and without hesitation. If it does not, turn main fuel adjusting screw out in 1/8 turn increments until engine accelerates smoothly, but do not turn out more than 1/2 turn beyond the original setting.

ENGINE COOLING AND AIR CLEANER

ENGINE COOLING

This tractor has an air-cooled engine. Air must be able to circulate freely around the engine, through the screen, shroud, and over the fins of the cylinder head and cylinder block. Keep these areas free of accumulated dirt and trash or engine will overheat and result in damaged moving parts. **Periodically** clean the inside of the engine compartment for adequate cooling.

NOTE:

This machine is designed to cool properly with the engine side panels in place. Operating the machine without panels in place may result in inadequate cooling. Never operate engine with blower housing or cooling shrouds removed. These direct air flow past cooling fins. Removal results in improper air circulation, overheating and engine damage.

DRY TYPE AIR CLEANER WITH FOAM PRE-CLEANER ELEMENT

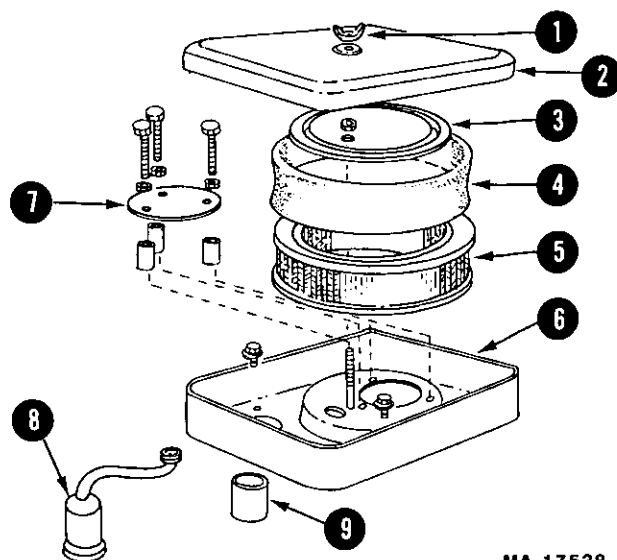

MA-17538

Air cleaner assembly

1. Wing nut
2. Cover
3. Element cover
4. Foam pre-cleaner element
5. Paper cartridge
6. Base
7. Air deflector plate
8. Breather tube
9. Air intake tube

Cleaning Foam Pre-Cleaner Element

Clean and re-oil foam pre-cleaner element at 1 month intervals or every 10 hours, whichever occurs first.

NOTE:

Service more often under dusty conditions.

1. Remove wing nut and cover.
2. Remove foam pre-cleaner element by sliding it up off of the paper cartridge.
3. A—Wash pre-cleaner element in liquid detergent and water. B—Squeeze dry in cloth. C—Saturate in engine oil. Squeeze to distribute oil evenly. D—Wrap in shop towel and squeeze to remove excess oil.

Discard used element and replace with new one at least once a year.

Servicing Paper Cartridge

This engine is equipped with a dry type air cleaner element, which should be checked every 100 operating hours and replaced if dirty. It should be checked and if necessary replaced more often under extremely dirty dusty conditions. Do not wash element in any liquid or attempt to blow dirt off with air hose as this will puncture filter element. Carefully handle new element—do not use if gasket surfaces are bent or twisted. Check the following when installing new element.

1. Base must be flat on O-ring of carburetor. Replace base if bent or cracked.
2. Gasket surfaces of element must be flat against base and cover to seal effectively.
3. Seal on cover must be in place to reduce noise and vibration of the cover. Vibration can cause stud hole in cover to enlarge, thus permitting dirt to enter carburetor.
4. Wing nut must be finger tight—do not over-tighten.

Properly cleaned and installed air cleaner elements are the best guarantee to continued long and satisfactory engine life.

ELECTRICAL SYSTEM

The twelve-volt electrical system consists principally of a rectifier, alternator, starting motor, and a twelve-volt battery, ignition coil, condenser, breaker points and spark plugs.

All connections must be clean and securely fastened.

SAFETY STARTING SWITCH

The safety starting switches activated by the neutral pedal and the power take-off clutch switch serve to prevent starting the engine accidentally. The neutral pedal must be depressed and the power take-off switch in "OFF" position before engine will start.

SEAT SAFETY SWITCH

When using power take-off operated equipment, the operator must remain in tractor seat at all times. If operator should leave tractor seat without turning off the power take-off switch, the engine will automatically shut off.

CHARGE INDICATOR

This instrument indicates whether the alternator is charging or the battery is discharging. If it shows discharge continuously, investigate the cause to avoid completely discharging the battery and possible damage to the charging circuit.

HOUR METER

The hour meter is located on the instrument panel. It indicates the actual hours of engine operation, enabling the operator to determine without guesswork, when lubrication, change of oil or periodic inspections are necessary. It also provides a means of computing cost of specific jobs. The hour meter operates whenever the engine is running or the ignition key is in the "ON" position.

When the red hand is located on the red areas of the hour meter dial (every 10 hours), this indicates a service period is necessary. Refer to "Maintenance Chart" and "Lubrication Guide" for 10 and 30 hour service requirements.

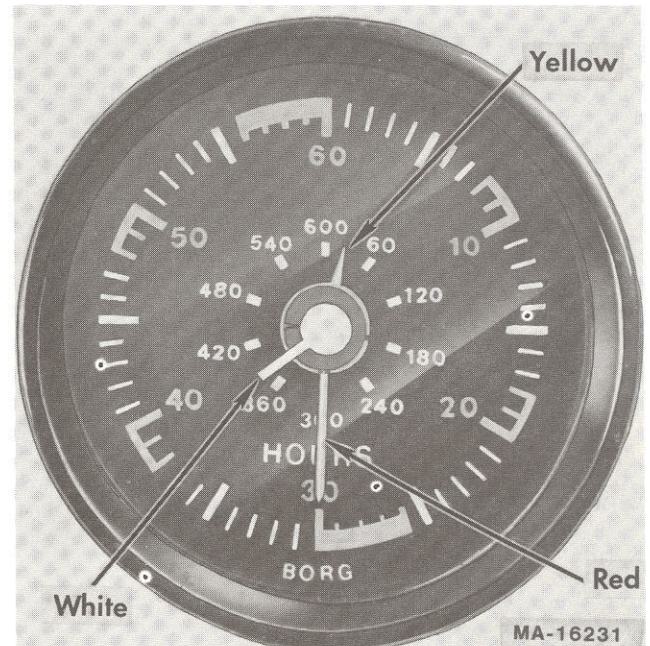

The red dial indicates the number of hours from 0 to 60. The yellow dial indicates the total hours of operation up to 600. For one revolution of the red dial the yellow dial moves 1/10 of a revolution. The white dial indicates that the hour meter is operating.

COMBINATION LIGHTS AND IGNITION SWITCH

The combination lights and ignition switch is a four position switch.

Refer to chart for various operating positions.

Switch Position	Lights	Ignition
1	Off	Off
2	On	On
3	Off	On
4	Off	Actuates starting motor

NOTE:

When the engine is not operating, the key must be turned to the "OFF" position to prevent battery discharge.

The headlights are sealed-beam units. Refer to "Specifications" when replacement is necessary. To replace the taillight lamp, remove socket and bulb from the back of the taillight by rotating socket 1/4 turn. Refer to "Specifications."

SPARK PLUGS

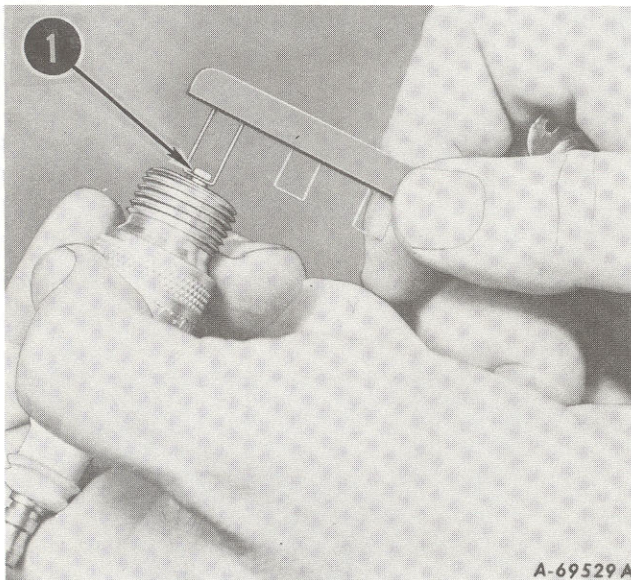

Checking the spark plug gap.
Set gap at .025-inch (.64 mm).



WARNING

To avoid possible injury, be sure engine is off and cool before making any adjustments or repairs.

NOTE:

Remove all dirt from around the spark plugs before removing.

Remove the spark plug after every 100 hours of operation for cleaning and checking the gap. When adjusting the gap, always bend the outer electrode. Never bend the center electrode. If gap between the electrodes is too great, the engine will misfire and be hard to start.

Always use a spark plug wrench when removing or reinstalling the plug.

Cleaning Spark Plug

Clean spark plug with a pen knife or wire brush and solvent. If electrode is burned away or the porcelain is cracked, replace with new plug.

NOTE:

Do not use abrasive cleaning machine; because any grit introduced into the engine could cause severe damage.

Replace a defective plug with a new plug. Use a Champion RBN 13Y or equivalent. Install the new plug finger-tight, and complete the installation with a plug wrench. Tapered seat plugs do not use gaskets and require about one-sixteenth (1/16) turn to effect a gas tight seal. If a torque wrench is used, tighten to 10-15 ft. lbs. (13.5-20.3 N-m). See your authorized dealer for the correct replacement plug.

FUSES (Electric Lighting and Electric Power Take-Off Clutch)

There are two fuses on the tractor pedestal. The fuse on the left is for the lights; the fuse on the right is for the electric clutch.

Always use the same capacity fuse for replacement. Refer to "Specifications." If the lights fail or the electric clutch does not engage, check the appropriate fuse.

To install a new fuse, press in on the fuse housing cap and turn counterclockwise to remove it from the fuse housing. Remove the old fuse and replace it with a new one. Then reassemble the cap to the housing.

BATTERY

 DANGER	Cigarettes, flames or sparks could cause battery to explode. Always shield eyes and face from battery. Do not charge or use booster cables or adjust post connections without proper instruction and training.
	EXPLOSIVE GASES/POISON CAUSES SEVERE BURNS KEEP OUT OF REACH OF CHILDREN
	Contains sulfuric acid. Avoid contact with skin, eyes or clothing. In event of accident flush with water and call physician immediately.

MA-17150

Before working on any part of the electrical system, disconnect the battery ground cable at the battery negative (-) terminal. Do not reconnect this cable until all work has been completed. This will prevent shorting and damage to any of the electrical units. Examine the electrical cables occasionally to be sure they are not being frayed by contact with adjacent parts.

When replacing a battery, make certain the ground cable is connected to the negative (-) terminal on the battery. Be sure the rubber boot is properly positioned over the positive (+) terminal on the battery.



NOTE

Both cables must be assembled with the nuts to the inside of the terminals to prevent shorting against fender well.



NOTE

All circuits must be turned "Off." Electrical system is **NEGATIVE (-)** grounded only. Reversed polarity will result in permanent damage to components of the electrical system.

Cleaning and Servicing the Battery

Occasionally remove the battery cables and brighten the terminal contact surfaces with wire wool, and reassemble them. Apply a light coat of vaseline or chassis lubricant. Be sure the terminals are clamped tightly and that the battery is fastened securely in the battery box. Replace unserviceable cable. Keep the vent holes in the battery filler caps open.

Keeping the battery fully charged not only adds to its life but makes it available for instant use when needed.

Liquid Level

Check the battery at least once a month for electrolyte level.

The electrolyte (acid and water) in each cell should be at ring level at all times to prevent battery failure. When the electrolyte is below this level, add pure, distilled water.

Acid or electrolyte should never be added except by a skilled battery man. Under no circumstances add any special battery "dopes," solutions or powders.



WARNING

If the tractor is to be tipped up or on its side remove the battery to avoid spilling the electrolyte. Battery electrolyte is poisonous and can be injurious to eyes, skin, and clothing. If electrolyte is spilled, flush immediately with water, followed by a solution of one part baking soda to four parts water.

Connecting Booster Batteries

When required, a booster 12-volt battery may be connected in parallel with the 12-volt system on the tractor.



WARNING

Gas discharged by battery is explosive. Avoid sparks near the battery.

The first jumper cable must connect the positive (+) terminal of the booster battery and the positive terminal of the battery on the tractor.

The second jumper cable must first be connected to the negative (-) terminal of the booster battery; and then to a point on the frame of the tractor, away from the battery, having a good ground, so no spark occurs near the battery.

For dependable battery service, see your authorized dealer.

HYDRAULIC LIFT

The hydraulic lift is ready to operate when the engine is running.

OPERATING INSTRUCTIONS

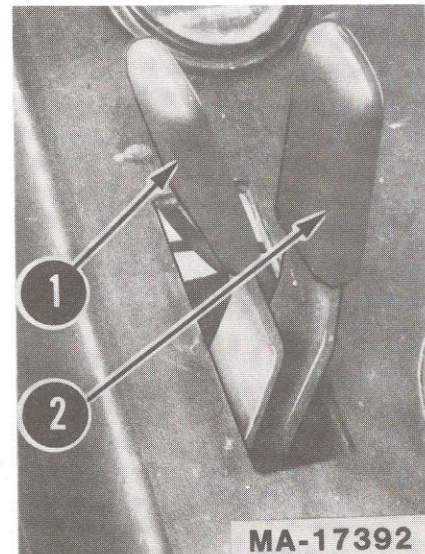

1. Hydraulic lift control lever
2. Front hydraulic outlet control lever (Optional)

The hydraulic lift control lever is spring loaded. To raise the equipment move the lever back, toward the tractor seat. To lower the equipment move the lever forward.

The front hydraulic outlet control lever (optional) provides for "on-the-go" angling of a front mounted blade.

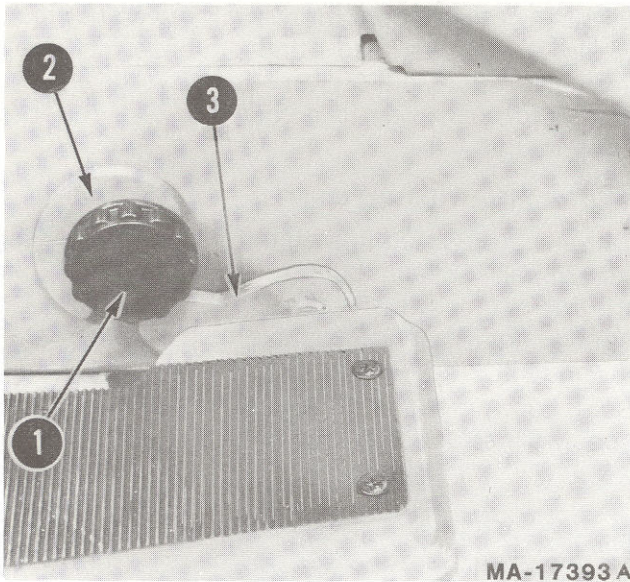

1. Locking knob
2. Cam stop
3. Tang

The cam stop may be adjusted to allow the implement to return to a single preset height.

With implement in desired height position, release cam stop by turning locking knob counter-clockwise. Turn cam stop until it contacts tang. Lock cam stop into this position by turning cam knob clockwise.

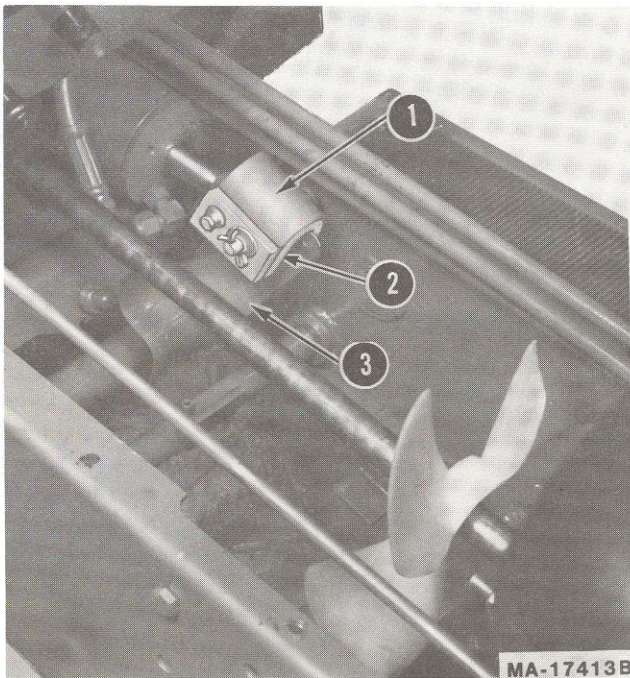

1. Lift bracket
2. Hole (not seen) for bolt
3. Lift arm

Equipment is normally operated in a "Float" position (implement free to move upward).

To operate equipment in a fixed "Locked" position, where down pressure of the implement is required (blade work), remove frame cover and install bolt, 1/2 x 1-1/8-inch, (not furnished with tractor) between the lift arm and lift bracket.

HITCHING EQUIPMENT TO THE TRACTOR

THREE-POINT HITCH (Optional)

When the tractor has a three-point hitch, equipment adaptable to this hitch is raised or lowered with the hydraulic lift control lever. Refer to "Hydraulic Lift."



WARNING

To prevent an accident disengage power to any attachment when transporting or not in use.

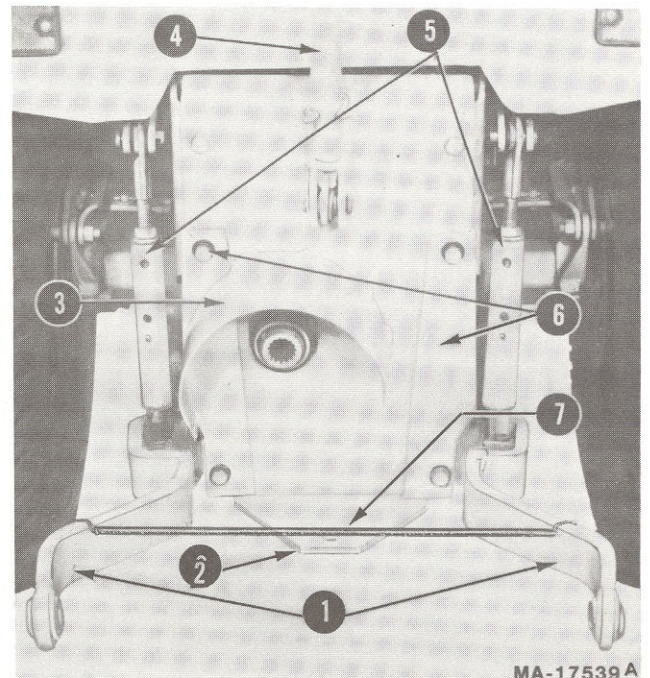

- | | |
|------------------|--|
| 1. Lower links | 5. Lift links |
| 2. Fixed drawbar | 6. Cam sway limiters
plates (sway position) |
| 3. PTO shield | 7. Sway limiter spring |
| 4. Upper link | |

Drawbar and three-point hitch.

The tractor hitch has three points for attaching mounted implements. Two points are for pulling and lifting the implement, and the third point is for holding the implement level. The tractor hitch conforms to the specifications for Category 0 tractor hitch established by the A.S.A.E. and the S.A.E.

NOTE:

Refer to the equipment manual for proper hitching instructions.

LIFT LINK ADJUSTMENTS

To level an implement from side to side, loosen jam nuts, insert a round bar in hole in the lift link tube and turn the lift link tube clockwise to lengthen the link or counterclockwise to shorten the lift link. When the desired length has been obtained tighten jam nuts.

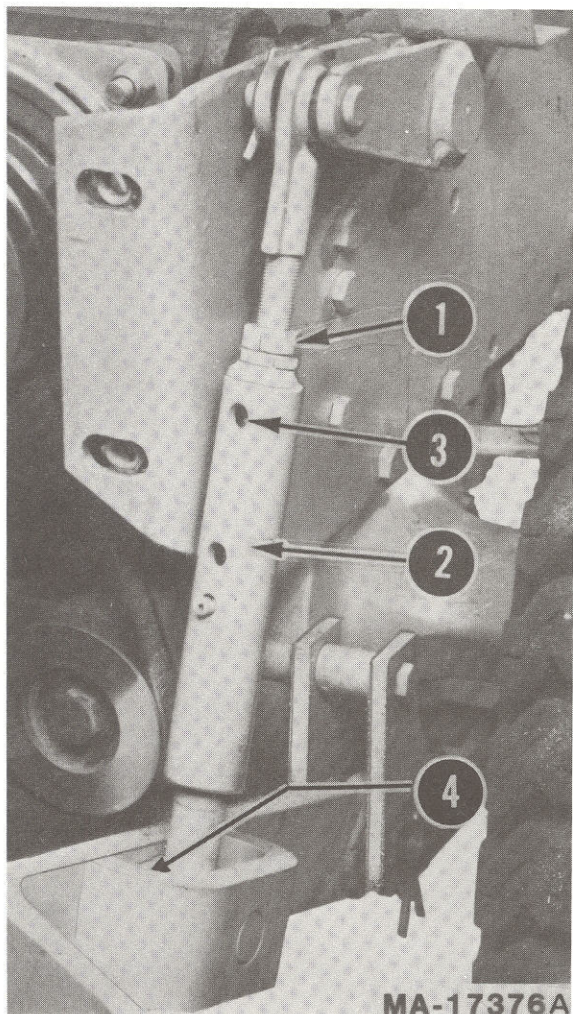

- 1. Jam nut
- 2. Lift link tube
- 3. Lift link tube hole
- 4. Grease fitting

Every 10 hours of operation, apply several strokes of No. 2 multi-purpose lithium grease at the lift link and lower link connection. Add enough grease to flush out old grease and dirt. Refer to "Lubrication Guide."

UPPER LINK ADJUSTMENT

To level a mounted implement from front to rear, turn upper link ball counterclockwise to lengthen the link or clockwise to shorten the link. When the hitch is not in use the upper link should be placed in the bail.

See your implement Operator's Manual for specific instructions.

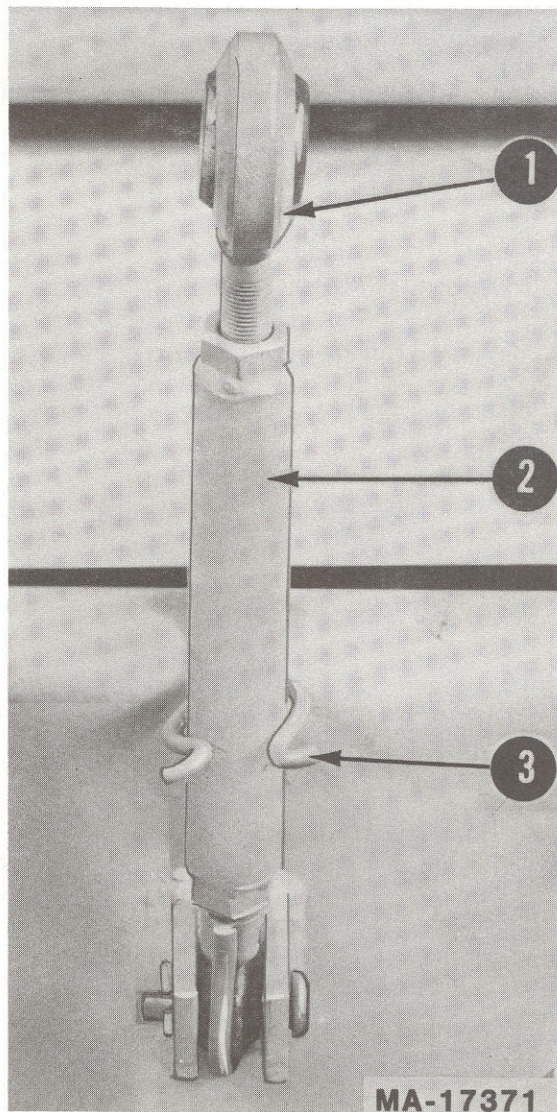

- 1. Upper link ball
- 2. Upper link
- 3. Bail

CAM SWAY LIMITER PLATES

The cam sway limiter plates can be mounted in two positions, the sway position, shown in illustration, or the non-sway position.

The sway position allows side sway of the lower links. To mount the cam sway limiter plates in the sway position, the indentation should be facing outwards. As the lower links move up, the cam sway limiter plates force the links out to the side eliminating sway in transport position.

To mount the cam sway limiter plates in the non-sway position, switch the plates so the indentation is toward the power take-off shaft. As the lower links are raised they will not be allowed to sway in any position.

See your implement Operator's Manual for specific instructions.

COUPLING THE EQUIPMENT TO THE THREE-POINT HITCH

Hitching an implement to the tractor is easier if both are on reasonably level ground.

Back the tractor to the implement so the hitch holes in the lower links are in line fore and aft as close as possible with the implement hitch pins.

Lower the hitch, using the hydraulic lift control lever, until hitch holes in the lower link are in line with the implement hitch pins. Final alignment can be made by turning the lift link tube clockwise or counterclockwise as needed. Refer to "**Lift Link Adjustments.**" Insert the implement hitch pins into the hitch holes in the lower links.

Adjust length of upper link, refer to "**Upper Link Adjustment,**" until ball lines up with implement holes. Connect upper link to implement.

Adjust the hitch as described in your implement Operator's Manual.

UNCOUPLING THE IMPLEMENT

Lower the implement to the ground. Remove the pins from the three hitch holes. If the pins are difficult to remove, slightly raise or lower the hitch until the pins are free.



WARNING

Securely block the implement before disconnecting it from the tractor to prevent the implement from falling or tipping over, which could result in accident or injury.

DRAWBAR

Drawbar equipment must be hitched to the tractor only at the hitch hole in the drawbar.

REAR POWER TAKE-OFF (Optional)

OPERATING THE REAR POWER TAKE-OFF CLUTCH

The rear power take-off is an electric clutch operated by a toggle switch to the right of the combination lights and ignition switch. Refer to "**Instruments and Controls.**"

1. Move the throttle lever back to the medium or "**SLOW**" position.
2. Flip the toggle switch to the "**ON**" position.
3. Advance throttle to operating speed (full speed).
4. The operator must remain in tractor seat at all times. If operator should leave tractor seat without turning off the power take-off switch, the engine will automatically shut off.

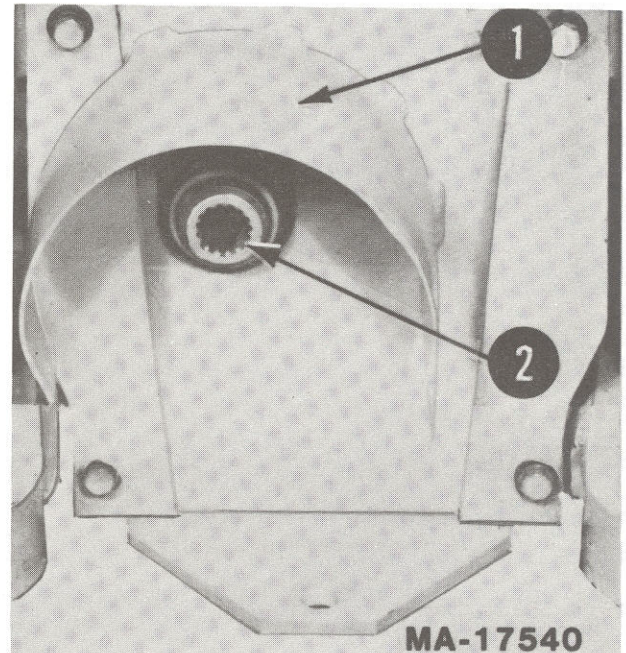

1. Power take-off shield
2. Power take-off output shaft

ADJUSTING THE POWER TAKE-OFF CLUTCH

If the clutch fails to operate properly, check fuse on pedestal. If this does not correct the problem, see your authorized Cub Cadet dealer. There are no adjustments possible on rear PTO clutch.



CAUTION

To avoid possible injury, always disengage all clutches, shift the transmission into neutral, depress the brake, set the brake pedal lock and turn the ignition "OFF" before working on the machine.

ATTACHING EQUIPMENT TO POWER TAKE-OFF SHAFT

Depress collar and hold. Insert spline shaft of the equipment being attached into the internal spline opening of the power take-off output shaft. Pull collar rearward to lock.

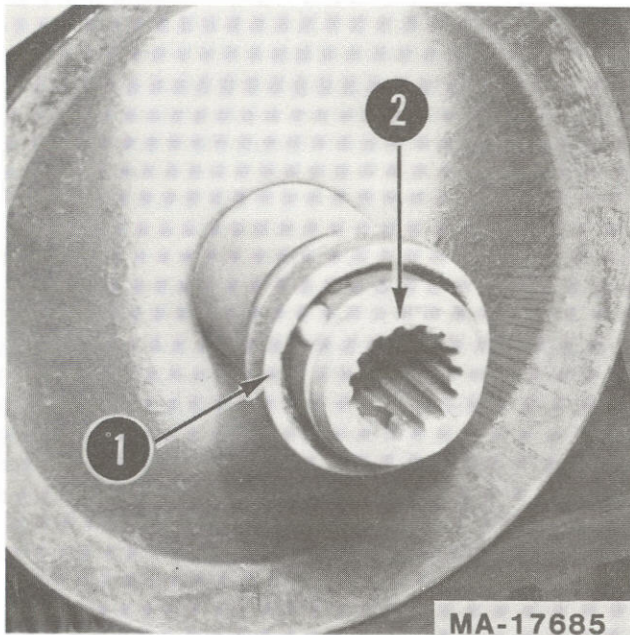

- 1. Collar
- 2. Power take-off output shaft

FRONT POWER TAKE-OFF

OPERATING THE FRONT POWER TAKE-OFF CLUTCH

The front power take-off is an electric clutch operated by a toggle switch on the left side of the instrument panel.

1. Move the throttle lever back to the medium or "SLOW" position.
2. Flip the toggle switch to the "ON" position.
3. Advance throttle to operating speed (full speed).
4. The operator must remain in tractor seat at all times. If operator should leave tractor seat without turning off the power take-off switch, the engine will automatically shut off.

ADJUSTING THE POWER TAKE-OFF CLUTCH

The clutch is factory adjusted and should not require further adjustment under normal operating conditions. However, if the clutch fails to operate properly check as follows:

Check fuse on pedestal.



CAUTION

To avoid possible injury, always disengage all clutches, shift the transmission into neutral, depress the brake, set the brake pedal lock and turn the ignition "OFF" before working on the machine.

Using a feeler gauge, check the air gap. Insert the feeler gauge into one of the three access slots located around the outside of the brake plate. The air gap should be .018-.022-inches (.254-.381 mm). Adjust the self-locking nuts to obtain proper clearance. Repeat adjustment at all three access slots.

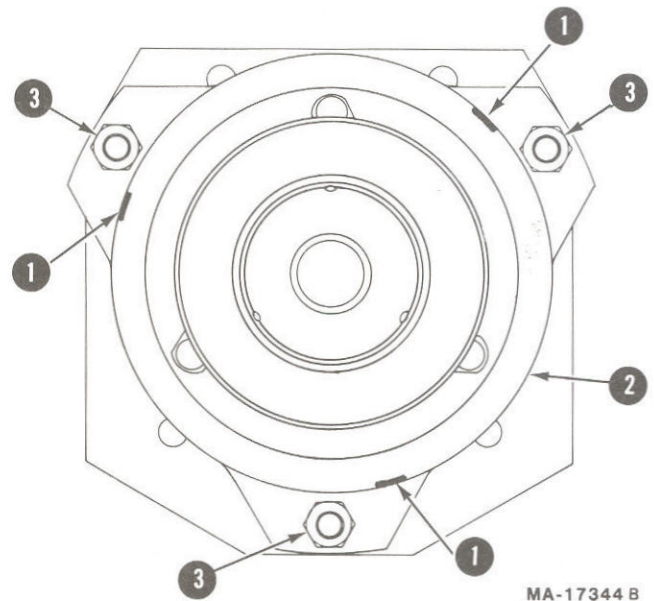

- 1. Access slots
- 2. Brake plate
- 3. Self-locking nuts

If the above procedure does not work, see your authorized dealer.

BRAKES

During normal operation on this machine, the brakes are subject to wear and will require periodic examination and adjustment.

OPERATING THE DUAL BRAKE PEDALS

The two brake pedals are used for individual braking of the rear wheels to aid in turning the tractor in soft soil conditions. Depress the right brake pedal to slow or stop the right rear tractor wheel, depress the left brake pedal to slow or stop the left rear tractor wheel. The tractor will turn in the direction of the wheel that is slowed or stopped.

The brake pedal lock is located in the top edge of the right brake pedal and is used to lock the two pedals together to provide simultaneous braking to both rear wheels when the brake pedal is depressed. If the dual brake pedals are not locked together and the neutral pedal is used, only the left rear tractor wheel is slowed or stopped.

It is recommended that the brake pedals be locked together when mowing lawns. If individual brakes are applied while moving, the wheel being braked may skid and cause lawn damage. **Refer to "Operating the Tractor."**

DUAL BRAKE ADJUSTMENT

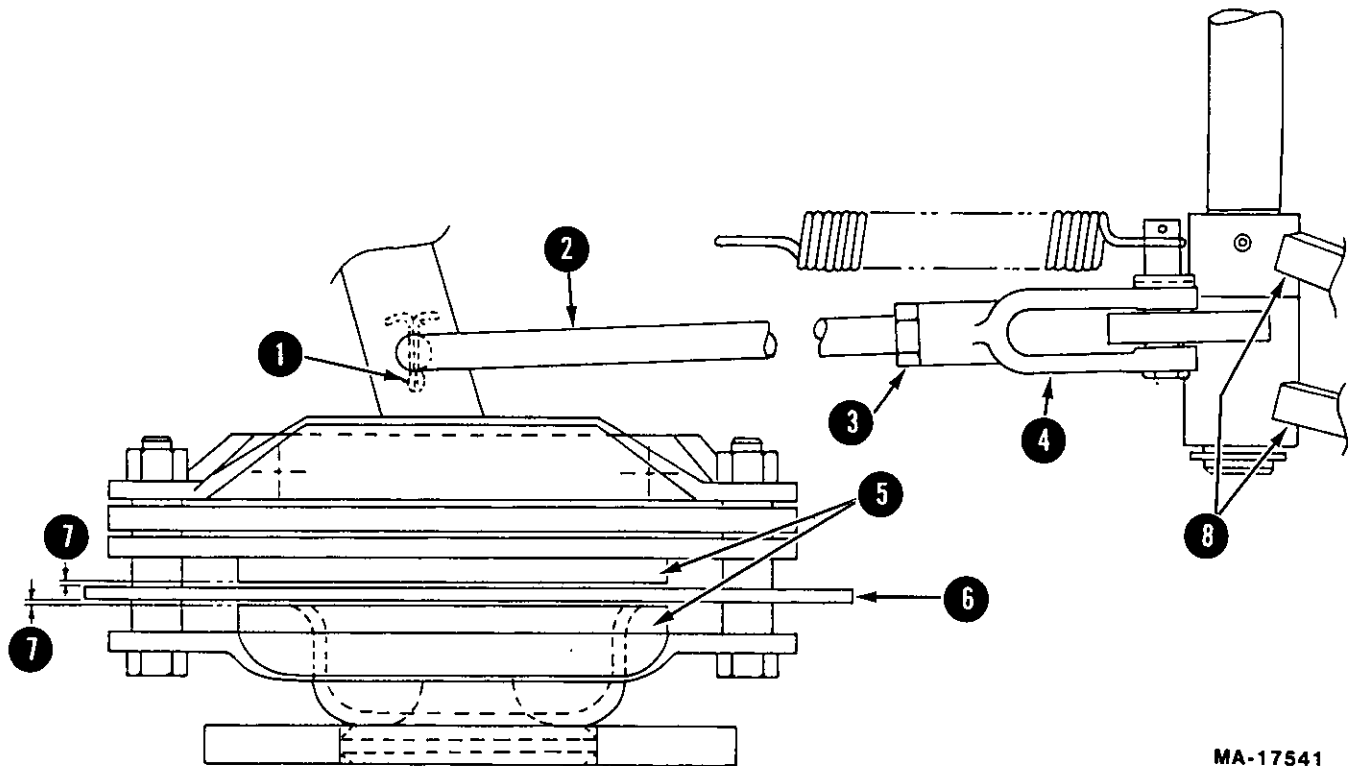

1. Cotter pin and washer (Both sides)
2. Brake rod (Both sides)
3. Jam nut (Both sides)
4. Clevis (Both sides)
5. Disc pads (Both sides)

6. Rotor (Both sides)
7. Clearance between disc pads and rotor (Both sides)
8. Dual brake pedal arms

Right side shown.

Do not lock neutral pedal. Latch dual brake pedal together. Remove cotter pins and washers from rear end of brake rods and loosen jam nuts from clevises. Block the front wheels and raise rear wheels. Adjust each brake rod in turn by turning the brake rod in the clevis with the other brake rod disconnected. Adjust the rods so there is a

minimum amount of clearance (no drag) between disc pads and rotor.

Reinstall cotter pins, washers, and tighten jam nuts. Brakes must not drag with pedal in the up position. If necessary, loosen rods one turn at a time until drag is eliminated.

FRONT WHEELS

FRONT WHEEL TOE-IN

The front wheel toe-in dimension is approximately 1/8-inch (3.2 mm) closer in front than in the rear. To measure for proper toe-in, make a chalk mark on the center line of each tire the same height from the ground as the front wheel hubs. Measure the distance between the marks "A", then rotate the tires so that the marks are toward the rear of the tractor, the same height from the ground as they were in front. The dimension should be approximately 1/8-inch (3.2 mm) larger at the rear.

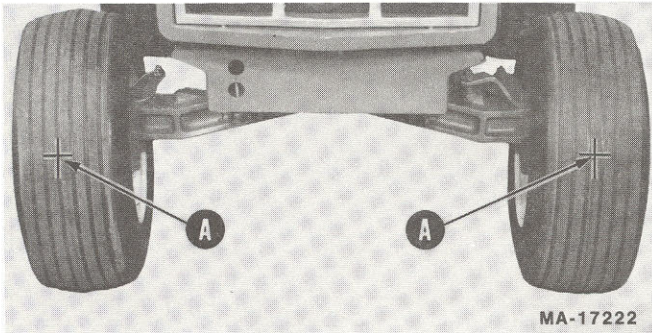

Front wheel adjustments.

To adjust the toe-in remove one ball joint, loosen the lock nut "C" at the ball joint and turn the tie rod ball joint in or out as required.

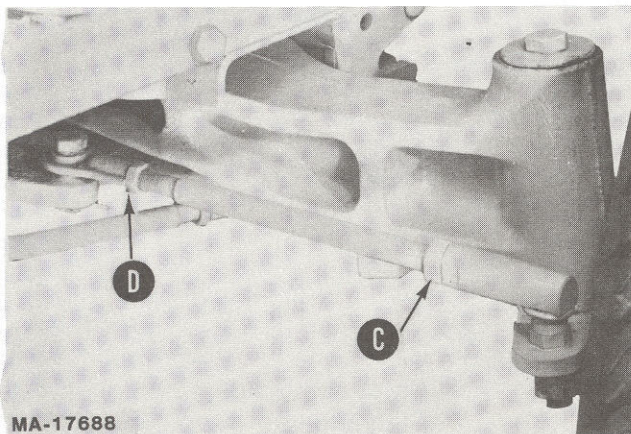

Tie rod and drag link ball joints.

TURNING RADIUS

The front wheels should have an equal angle for left and right turns. If adjustment is necessary, remove ball joint and loosen lock nut "D", turn the drag link ball joint clockwise or counterclockwise as required.



WARNING

Be sure all parts are reassembled tight with cotter pins in place and spread.

PNEUMATIC TIRES

26 x 12.00-12 rear turf tread and 18 x 8.50-8 front ply tubeless tires with wheels are standard equipment.

The high flotation tires provide maximum mobility in sand, snow, and soft soil conditions. The reduced ground pressure and low inflation provides maximum protection for turf, soil and crops.

INFLATION

Keep the pneumatic tires properly inflated. Over-inflation will cause operator discomfort. Under-inflation will cause short tire life.

Always see that the tire valve caps are in place and tightened securely to prevent loss of air and protect the valve core and stem.

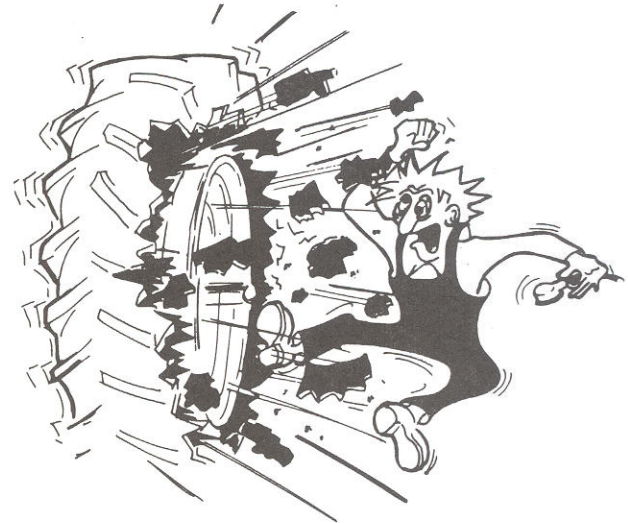

WARNING

Use a clip on air chuck, extension hose with gauge, and stand away from the tire while inflating to prevent the possibility of personal injury due to blowoffs, etc.

OPERATING PRESSURE FOR TIRES

Inflate the front and rear tires for normal or heavy load operations as shown in the following table.

Tire Size	Pounds per square inch
Front Tires	
18 x 8.50-8	12
Rear Tires	
26 x 12.00-12	12

CARE OF TIRES

Avoid stumps, stones, deep ruts, curbs, and other hazards. Cuts in tires should be repaired immediately as neglect decreases the tire life.

Keep tires free from oil and grease as both destroy rubber.

After using the tractor for spraying operations, use water to remove any chemicals that may be on the tires.

REAR WHEEL WEIGHTS (Optional)

Rear wheel weights increase traction and reduce wheel slippage. The weights weigh approximately 75 pounds (34 Kg) each. They are attached to each rear wheel with two bolts, lock washers, and hex nuts.

If additional weight is desired, a second set of weights can be attached to each first weight by using two longer bolts.

MOUNTING TIRES ON THE RIM

After mounting a tire on the rim, inflate it to 20 pounds pressure to seat the tire bead on the rim flange. Then deflate the tire to the correct operating pressure.

NOTE:

After the first 10 hours of operation, check and retorque the ten wheel lug bolts (both sides) to 47 lbf. ft. (64 N-m) to make sure they have seated properly.

TIRE CHAINS (Optional)

Tire chains will provide additional traction for wet ground conditions, when plowing snow, or pulling heavy loads. Rear wheel weights are recommended when using chains.

OVERLOADING

Do not overload the tractor tires by mounting equipment on the tractor which exceeds the load capacity of the size of the tires on the tractor.

Seat Maintenance

Clean the seat regularly, using a silicone base vinyl cleaner. Do not use solvents or vinyl cleaners with a toluene or alcohol base as these will damage the seat.

Avoid prolonged exposure to sunlight as sunlight deteriorates vinyl. When not in use, store tractor indoors if possible. If stored outdoors, keep seat covered to protect it from weather extremes.

In extremely cold weather vinyl becomes brittle and care must be taken to avoid cracking the seat by sudden pressures or sharp cornered objects.

Small tears can be repaired using ordinary vinyl electrical tape, available in hardware stores.

STORING THE TRACTOR



CAUTION

Exhaust fumes can kill. Never run engine inside buildings.

When your tractor is not to be used for some time, it should be stored in a dry and protected place. Leaving your tractor outdoors, exposed to the elements, materially shortens its life.

Follow the procedure outlined below when storing a tractor for an extended period of time.

1. Wash or clean and completely lubricate the tractor. Refer to "Lubrication Guide."
2. Store the tractor so the tires are protected from sunlight. Before storing the tractor, clean the tires thoroughly. Jack up the tractor so the load is off the tires when it is to be out of service for a long period. If not jacked up, inflate the tires at regular intervals.



WARNING

If tractor is jacked up or placed on blocks, be sure it is done so it cannot be tipped over or fall on someone.

3. Run the engine long enough to thoroughly warm the oil in the crankcase and then drain the oil. Refill the crankcase with fresh oil as specified in the "Lubrication Table" and run the engine for about five minutes.
4. Drain the fuel tank and run the engine until the fuel is exhausted from the fuel system.

NOTE:

Gum will eventually form in the fuel tank line and carburetor if the fuel system is not drained.

5. After the engine has cooled, remove the spark plug and pour two tablespoonsful of a rust inhibited oil such as Hy-Tran® or IH No. 1® engine oil into each cylinder. Crank engine slowly to distribute the oil over the cylinder walls. Then replace spark plug.
6. Clean the exterior of the engine.
7. Remove the battery and place it in a cool, dry place above (+ 32° F.) (0° C.). Check battery at least once a month for electrolyte level and amount of charge. Refer to **“Battery.”**

REMOVING FROM STORAGE

1. Fill the fuel tank and be sure the grade of oil in the crankcase is according to the temperature range in the **“Lubrication Table.”**
2. Install a fully charged battery and properly connect.
3. Check air pressure in tires.
4. Start the engine and let it run slowly. Do not accelerate it rapidly or operate at high speed immediately after starting.



WARNING

Do not run the engine in confined areas such as storage buildings any longer than is necessary. Move the tractor outside into the air. EXHAUST GASES ARE TOXIC. OPENING DOORS AND WINDOWS MAY NOT PROVIDE ADEQUATE VENTILATION

OPTIONAL EQUIPMENT AND ACCESSORIES

When you purchased your tractor, you probably had it completely equipped for your particular needs at the time. However, later you may wish to obtain some of the equipment or accessories shown below. These items and other allied equipment can be purchased from, and installed by, your authorized dealer.

The tractor is used for so many different types of work, and because it is called on to operate under so many different conditions, a variety of equipment is available to adapt it to the requirements of the user.

Type of Equipment

Rear Wheel Weights
Three-Point Hitch (Category “O”)
Tire Chains
Tractor Cover
Utility Box
Front weight package

MAINTENANCE CHART

Operation to be performed	Before each use	10 hours or once a month	30 hours or three times a season	50 hours or twice a season	100 hours or yearly	Before storage
Clean engine inlet air screen		More often under dirty conditions X				
Check engine oil level	X					
Fill fuel tank	X					
Grease front axle pivot bolt			X			X
Lubricate brake shaft			X			
Re-oil and clean foam air pre-cleaner		X				
Service air cleaner paper cartridge					More often under dirty conditions X	
Check spark plugs					X	X
Change engine oil	After first 5 hours X			X		X
Check transmission oil level			X			
Replace transmission oil filter		After first 10 hours X		After first 50 hours X	Every 100 hours there-after X	
Lubricate steering gear housing					X	
Drain fuel						X
Clean cooling fins & external surfaces			X			
Lubricate steering knuckles (2) and steering arm		X				
Lubricate speed control linkage cam plates					X	
Check battery electrolyte level		X				
Replace engine oil filter				After first 50 hours X	Every 100 hours there-after X	

NOTE: When the red hand of the hour meter is in the red areas maintenance is required.

TROUBLE SHOOTING

Possible Cause

Possible Remedy

HARD TO START

No gasoline in fuel tank or carburetor	Fill the tank with gasoline; open the fuel shut-off valve. Check the fuel line, and carburetor.
Fuel line or carburetor clogged	Clean the fuel line and carburetor with commercial carburetor cleaner.
Gas filter plugged	Replace.
Water in gasoline	Drain the fuel tank and carburetor. Use new fuel and dry the spark plug.
Choked improperly. Flooded engine	Follow the starting instructions.
Defective ignition or loose wiring	Check the wiring, spark plug, or breaker.
Defective battery	Check and service. Refer to "BATTERY."
Spark plug dirty or improperly gapped	Clean, adjust the gap to .025-inch (.635 mm) or replace the plug.

ENGINE OPERATES IRREGULARLY OR KNOCKS

Engine incorrectly timed	*
Spark plug dirty; wrong gap or wrong type	Clean, reset the gap, or replace.
Poor or weak spark	Check the breaker points and breaker point opening, spark plug, and wiring.*
Carburetor setting incorrect	Adjust. Refer to "ENGINE AND FUEL SYSTEM."
Poor grade fuel or water in fuel	Drain and use a good grade of clean fuel.
Engine overheating	Refer to "ENGINE COOLING AND AIR CLEANER."
Engine valves at fault	*
Engine smokes	Adjust the carburetor. Check for worn piston and rings.*
Oil level will rise due to gasoline in crankcase	Refer to "OPERATING IN COLD WEATHER."
Air filter will become oil and fuel soaked	Refer to "OPERATING IN COLD WEATHER."
Engine leaks oil	Refer to "OPERATING IN COLD WEATHER."
Mis-firing	Refer to "OPERATING IN COLD WEATHER."
Other engine problems	*
Excessive oil in air cleaner	Be sure that dipstick is fully seated and all excess oil is squeezed out of pre-cleaner foam element.

LACK OF POWER

Air cleaner clogged	Service the air cleaner element. Refer to "ENGINE COOLING AND AIR CLEANER."
Engine overload	Reduce the load.
Engine overheated	Make sure air intake screen, shrouding and engine fins are free of accumulated dirt and trash. Refer to "ENGINE COOLING AND AIR CLEANER."
Poor fuel, too rich, or too lean a mixture	Refer to "ENGINE AND FUEL SYSTEM."
Fuel tank air vent clogged	Open the vent in the cap.
Air leakage between carburetor and engine	Remove air cleaner. Tighten the carburetor and manifold mounting nuts. Replace as instructed in "ENGINE COOLING AND AIR CLEANER."
Incorrect timing or faulty ignition	*
Brake drags	Adjust the brake. Refer to "BRAKE."

*See your authorized dealer.

TROUBLE SHOOTING

Possible Cause

Possible Remedy

ENGINE OVERHEATS

Insufficient cool air, dirty air intake screen, shroud or cooling fins	Keep the air intake area and cooling fins clean; Refer to "ENGINE COOLING AND AIR CLEANER."
Lean carburetor adjustment	Readjust; Refer to "ENGINE AND FUEL SYSTEM."
Oil level incorrect	Engine oil level must not be over the "FULL" mark or below the "LOW" mark. Refer to "ENGINE AND FUEL SYSTEM."

***See your authorized dealer.**

LUBRICATION TABLE

Point of Lubrication	Check at Hours	Change at Hours	Capacity	Anticipated Air Temperature		
				Above + 32°F. (0°C.)	+ 32°F. to 0°F. (0°C. to - 17.1°C.)	Below 0°F. (- 17.1°C.)
Engine Crankcase With or without oil filter	Check before each use	50	3.5 pts. (1.6L) with filter 3.2 pts. (1.5L) without filter	I.H. Low Ash Engine Oil SAE-30 Note: Do not substitute 10W-30 or 10W-40	I.H. Low Ash Engine Oil SAE-10W	I.H. No. 1 ^o Engine Oil SAE-5W-20 or SAE-5W-30
Hydro-drive unit mounted on transmission case with filter	30	Add as needed	14 pts. (6.6L) Approx.	IH Hy-Tran[®] Fluid If fluid is used which does not meet requirements of IH B-6 Specifications, International Harvester Co. will not be responsible for sub-standard performance such as lack of proper control, power or premature wear out of hydraulic components. Failures due to use of improper fluid or filters are not covered by warranty. For maximum protection, used IH Hy-Tran Fluid and IH filters.		
Steering gear housing	100 or Yearly	—	¼ lb (0.1KG)	Two strokes of the lubricator using IH-251H EP grease or equivalent No. 2 multi-purpose lithium grease.		
Steering knuckles, front axle pivot & steering arm	10			Use IH-251H EP grease or equivalent No. 2 multi-purpose lithium grease and apply two or three strokes of the lubricator or sufficient grease to flush out old grease and dirt.		
Front wheel bearings	100 or Yearly			Remove front wheels and pack bearings with IH-251H EP grease or equivalent No. 2 multi-purpose lithium grease and reinstall wheels.		
Drive shaft lubricating bushing	30			Use IH-251H EP grease and apply two or three strokes of the lubricator.		

LUBRICATION GUIDE

The life of any machine depends upon the care it is given. Proper lubrication is a very important part of that care.

Be certain that all lubrication fittings are assembled in place, using the lubrication illustrations as a guide.

Always lubricate the tractor thoroughly before taking it to the field. Use a pressure lubricating gun.

Be sure all fittings are free from dirt and paint so the lubricant is certain to enter the bearing.

Always force the lubricant through the full length of each bearing until it emerges at the end, carrying with it the worn lubricant and any dirt that may have entered the bearing.

Miscellaneous working parts not provided with lubrication fittings should be oiled daily with a good grade of lubricating oil.

Lubricant is cheap. Use plenty of it. Worn parts can be expensive to replace.

Keep your supply of lubricating oil and grease stored in clean containers, and covered to protect from dust and dirt.

Keep the lubricating gun nozzle clean and wipe dirt from grease fittings before lubricating.

The symbols in the illustration indicate the method of application and the hourly intervals to apply the lubricant.



Use a pressure lubricating gun and apply IH 251H EP grease (or equivalent No. 2 multi-purpose lithium grease) sufficient to flush out the old grease and dirt. Lubricate at hourly intervals indicated on symbols.



Dipstick, use to check engine oil before each use.

— Before Each Use

1—Engine dipstick.

Check the oil (with the engine stopped) and add sufficient new oil to bring it to the “**FULL**” mark on the dipstick. Do not overfill. Do not operate the engine if the oil level is below the “**LOW**” mark on the dipstick.

— After Every 10 Hours of Operation

2—Steering knuckles.
(Both sides)

Use IH 251H EP grease or equivalent No. 2 multi-purpose lithium grease and apply sufficient grease to flush out old grease and dirt.

3—Front axle pivot bolt.
(Right side)

Use IH 251H EP grease or equivalent No. 2 multi-purpose lithium grease and apply sufficient grease to flush out old grease and dirt. **NOTE:** It may be necessary to rotate the front axle to reach the grease fitting.

4—Steering lever.
(Left side)

5—Hydrostatic drive
hydraulic fluid oil filter.

NOTE: After the first 10 hours only, remove the oil filter and replace with a new filter. Refer to “**ENGINE AND FUEL SYSTEM.**” Change the oil filter after 50 hours and every 100 hours of operation thereafter.

Three-Point Hitch

If the tractor is equipped with a Three-Point Hitch, apply several strokes of IH 251H EP grease or equivalent No. 2 multi-purpose lithium grease at the lift link and lower link connection. Add enough grease to flush out the old grease and dirt.

Oil all joints not equipped with lube fittings.

— After Every 30 Hours of Operation

6—Hydrostatic drive
hydraulic fluid oil level
and filler.
(Center, under cover)

Check the oil (with the engine stopped) and add sufficient new oil to bring it to the “**FULL**” mark on the dipstick. Do not overfill. Do not operate the engine if the oil level is below the “**LOW**” mark on the dipstick.

— After Every 50 hours of Operation

7—Engine oil drain plug.

While the oil is warm, remove the drain plug and drain all of the oil from the crankcase. Replace the drain plug. Refill the crankcase with new oil up to the “**FULL**” mark on the dipstick. Refer to the “**LUBRICATION TABLE**” for the proper quantity and viscosity to use.

8—Hydrostatic drive
hydraulic oil filter.
9—Engine oil filter.

NOTE: After the first 50 hours only, remove the oil filter and replace with a new filter. Refer to “**ENGINE AND FUEL SYSTEM.**” Change the oil filter every 100 hours of operation thereafter.

NOTE: When the red hand of the hour meter is in the red areas maintenance is required.

— Every 100 Hours of Operation

10—Hydrostatic drive
hydraulic oil filter.

Change the oil filter and replace with a new filter. Refer to
“ENGINE AND FUEL SYSTEM.”

11—Engine oil filter.

12—Steering gear housing.
(Center bottom)

Once a year, apply two strokes of the lubricator, using IH 251H EP grease or equivalent No. 2 multi-purpose lithium grease.

NOTE: To locate the lubrication fitting, reach up under the left side of the tractor frame.

Speed Control Linkage

13—Cam plates.

Once a year, apply a light amount of IH 251H EP grease or equivalent No. 2 multi-purpose lithium grease.

Brake pedal shaft

Lubricate the brake pedal shaft and linkage with eight or ten drops of engine oil.

Three-Point Hitch

If the tractor is equipped with a Three-Point Hitch, apply several strokes of IH 251H EP grease or equivalent No. 2 multi-purpose lithium grease on the rockshaft hubs once a year. Add enough grease to flush out the oil, grease, and dirt.

Apply a few drops of engine oil to the threaded ends of the upper link and lift links.

SPECIFICATIONS

REAR POWER TAKE-OFF

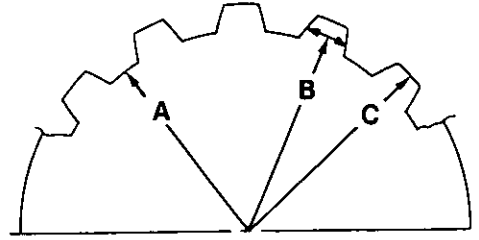
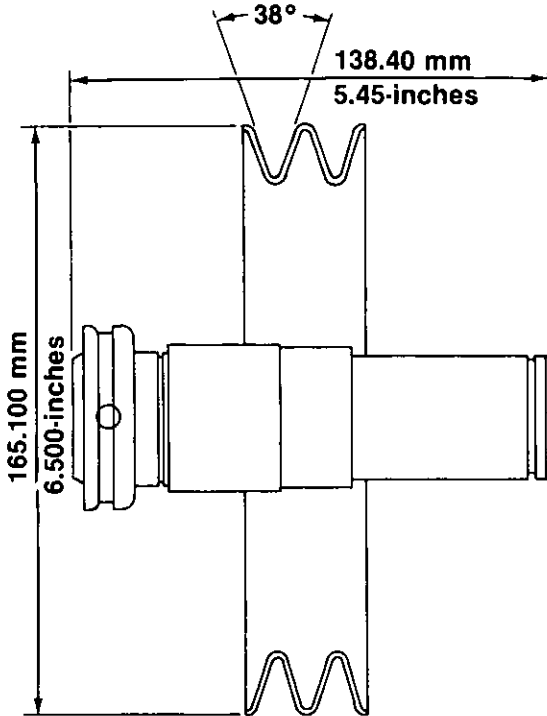

	ENGLISH	METRIC	
A	ROOT DIA.	.882/.887	22.40/22.53
B	PITCH DIA.	.9375	23.813
C	DIA. MAX.	1.011	25.68
	NO TEETH	15	15
	PRESSURE ANGLE	30°	30°

Machine for inside diameter fit.

MA-17543

Rear Power take-off shaft spline dimensions

Power take-off shaft
speed at full throttle 2000 r.p.m.

Direction of rotation (looking at
rear of tractor) clockwise

Center line of power take-off shaft
above rear axle center of 1.75-in.
(82.6 mm)

End of power take-off shaft to rear
of rear axle center line 10.0-in.
(188.9 mm)

SPECIFICATIONS

CAPACITIES

Fuel Tank	4 gals. (15.1 L)
Crankcase with filter	3.5 pts. (1.6 L)
Crankcase without filter	3.2 pts. (1.5 L)
Transmission case with Hydro-drive unit mounted	14 pts. (6.6 L)
Steering gear housing	¼ lb. (0.1 KG)

HYDROSTATIC DRIVE

Speed: Forward	0 to 8.2 mph (13.2 Km/h)
Reverse	0 to 4.04 mph (5 Km/h)

ENGINE

Make and model	Onan
(electric starting)	B48G
Cylinders	2
Bore	3.250-in. (82.6 mm)
Stroke	2.875-in. (73 mm)
Displacement (cubic inches)	47.7-in. ³ (782 cm ³)
Engine Speed	
(governed)	
Low speed	1200 RPM
High idle speed	
(no load)	3400 RPM
(full load)	3150 RPM
Valve clearance	
(engine cold)	.007-.009-in. (.177-.228 mm) (intake) .012-.014-in. (.304-.355 mm) (exh.)
Ignition	12-Volt Battery
Spark plug gap	
(14 mm plug) (Champion RBN-13Y or equivalent)	.025-in. (.64 mm) gap
Breaker points	.021-in. (.51 mm) gap
Timing	21 degrees BTDC

ELECTRICAL SYSTEM

System voltage	12 volt neg. ground
Battery	1HPRLU
Alternator	20 amp.
Fuse (cartridge type)	
Lights	AGC-10, 10 AMP. Slow Blow
Clutch	AGC-10, 10 AMP.* Slow Blow

*NOTE: If tractor is equipped

with rear PTO	3AG-15 amp. Slow Blow
---------------	--------------------------

Headlights	
all glass, sealed beam units	Lamp No. 4411-1 IH Part No. 126 470 C1
Taillight	Lamp No. 194 IH Part No. 20 627 R1

Front	18 x 8.50-8
Rear	26 x 12.00-12

Specifications are subject to change without notice.

SPECIFICATIONS

DIMENSIONS

Tread:

Front with 18 x 8.50-8 tires	33-in. (838 mm)
Rear with 26 x 12.00-12 tires	31.5-in. (800 mm)
Wheelbase	51.6-in. (1.31 m)
Length, over-all	78.5-in. (1.99 m)
Width, over-all	43.5-in. (1.1 m)
Height, over-all (to top of steering wheel)	47.5-in. (1.2 m)
Ground clearance	7.6-in. (194 mm)
Turning radius	7 ft. 2.5-in. (2.2 m)

Specifications are subject to change without notice.

MEASUREMENT UNITS

English Unit	Metric Equivalent (SI)
Area	
1 square inch (in ²)	6.45 square centimeter (cm ²)
1 acre	0.405 hectare (ha)
Force	
1 pound-force (lbf)	4.45 newton (N)
Length	
1 foot (ft)	304.8 millimeter (mm), 30.5 centimeter (cm), 0.305 meter (m)
1 inch (in)	25.4 millimeter (mm), 2.54 centimeter (cm)
1 mile	1609 meter (m), 1.61 kilometer (km)
Mass	
1 pound (lb)	0.454 kilogram (kg)
Power	
1 horsepower (hp)	0.746 kilowatt (kW)
Pressure	
1 pound-force per square inch, psi (lbf/in ²)	6.89 kilopascal (kPa), 0.00689 megapascal (MPa)
Temperature	
t degree Fahrenheit (°F)	$\frac{(t-32)}{1.8}$ degree Celsius (°C)
Torque	
1 pound-force foot (lbf-ft)	1.356 newton meter (N-m)
Velocity	
1 mile per hour (mph)	1.61 kilometer per hour (km/h)
Volume	
1 US bushel	0.035 cubic meter (m ³)
1 US gallon (US gal)	3.79 liter (L)
1 US quart (US qt)	0.946 liter (L)

Accidents can be prevented with your help

No accident-prevention program can be successful without the wholehearted co-operation of the person who is directly responsible for the operation of equipment.

To read accident reports from all over the country is to be convinced that a large number of accidents can be prevented only by the operator anticipating the result before the accident is caused and doing something about it. No power-driven equipment, whether it be transportation or processing, whether it be on the highway, in the harvest field or in the industrial plant, can be safer than the man who is at the controls. If accidents are to be prevented—and they can be prevented—it will be done by the operators who accept a full measure of their responsibility.

It is true that the designer, the manufacturer, the safety engineer can help; and they will help, but their combined efforts can be wiped out by a single careless act of the operator.

It is said that ***“the best kind of a safety device is a careful operator.”*** We ask you to be that kind of an operator.

1 096 352 R2. 7-

INTERNATIONAL HARVESTER COMPANY
401 NORTH MICHIGAN AVE. / CHICAGO, ILLINOIS 60611 / U.S.A.

PRINTED IN UNITED STATES OF AMERICA

772-30