



Installing Instructions

PARTS LIST

**INTERNATIONAL[®]
DANCO**

Underdrive

(Model UD-6)

for

**INTERNATIONAL[®]
CUB[®] CADET**

Tractor

INTERNATIONAL HARVESTER COMPANY

180 North Michigan Ave.

Chicago 1, Illinois, U.S.A.

To engage the underdrive, push down on the clutch pedal and forward on the underdrive shift lever.

It is the policy of International Harvester Company to improve its products whenever it

is possible and practical to do so. We reserve the right to make changes or add improvements at any time without incurring any obligation to make such changes on products sold previously.

INSTALLING INSTRUCTIONS

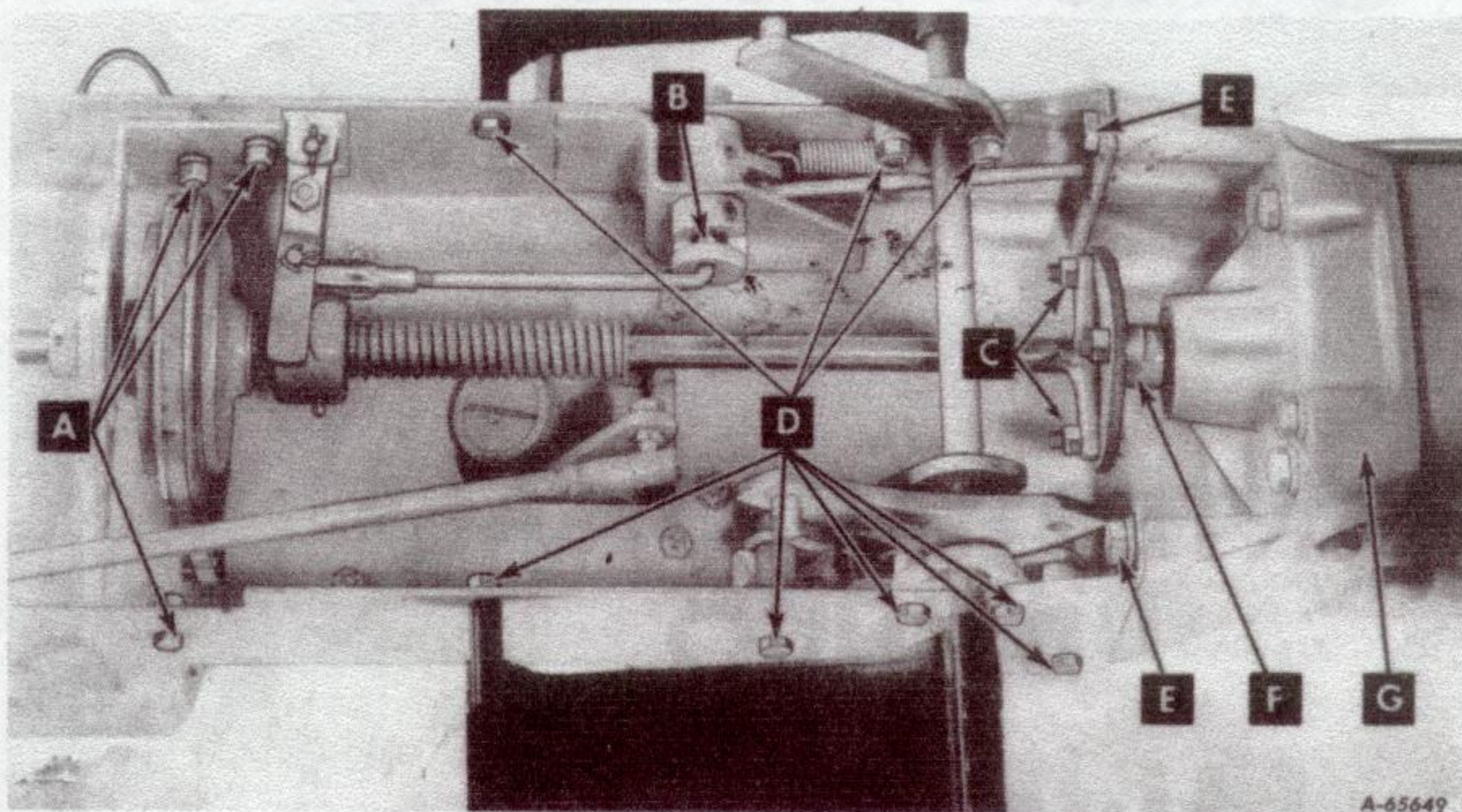

Illust. 1

1. To mount the underdrive, you must first completely remove the clutch assembly. Remove the three cap screws "A" (Illust. 1) from the drive shaft bearing support. Remove the cotter pin "B" from the clutch operating rod and the two cap screws "C" from the rear of the drive line. Remove the drive belt from the engine, then slide the complete unit forward until the rear end of the clutch shaft is out of its pilot hole in the reduction drive shaft coupling. Lower the clutch assembly from under the tractor.

2. The clutch assembly is to be removed from the drive shaft as follows:

A. Loosen the set screw in the bearing collar, remove the collar and clutch shaft bearing support from the shaft.

B. Place the shaft assembly in a press. Using slotted washer FES 10-3 (Illust. 2), compress the clutch loading spring until the 1/8 x 7/8-inch Spirol pin can be driven out. Release the press slowly until the clutch loading spring is fully expanded.

C. Slide the rear pressure plate to the rear of the clutch shaft and drive out the remaining two spirol pins. All parts can now be removed from the clutch shaft.

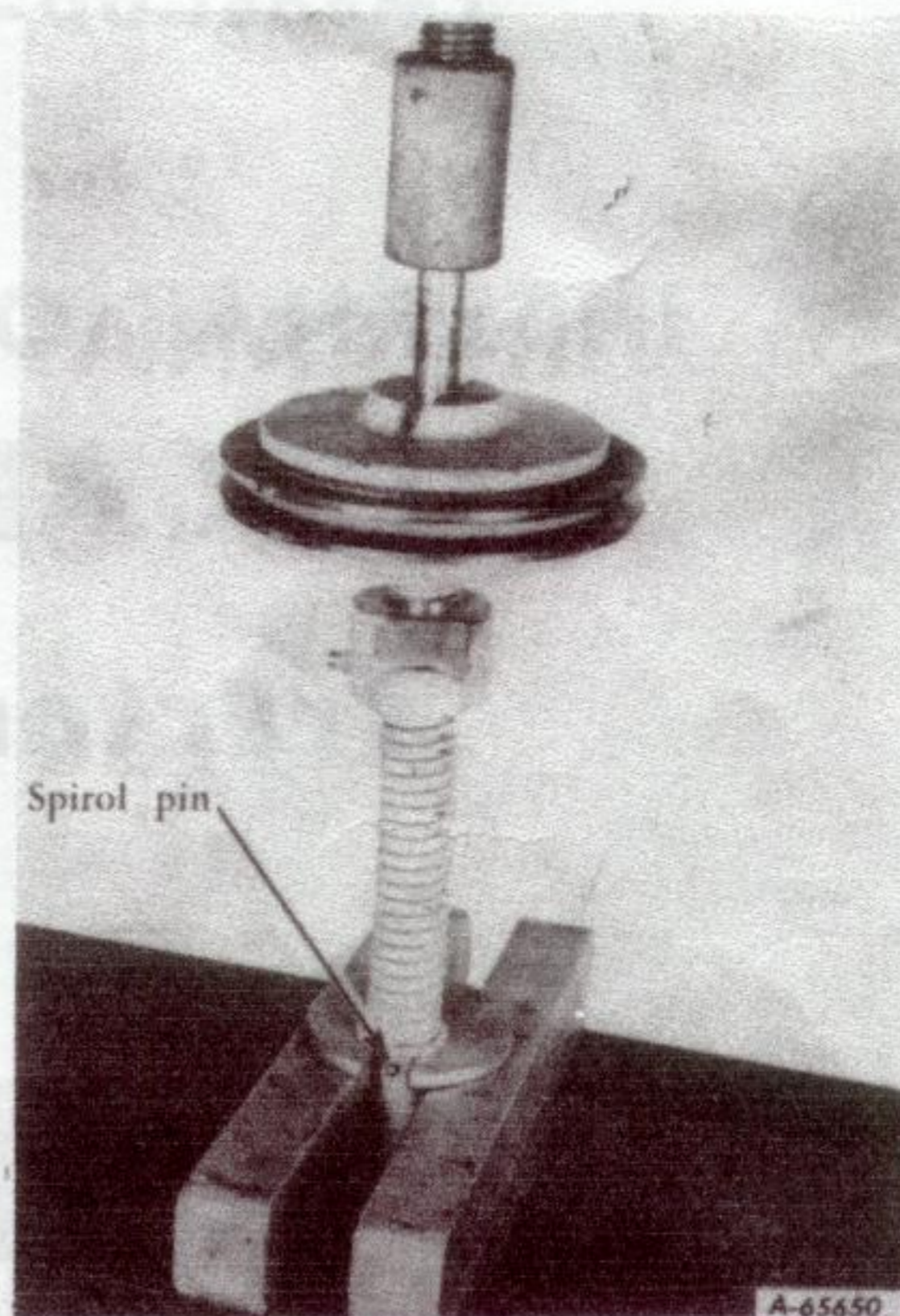

Illust. 2

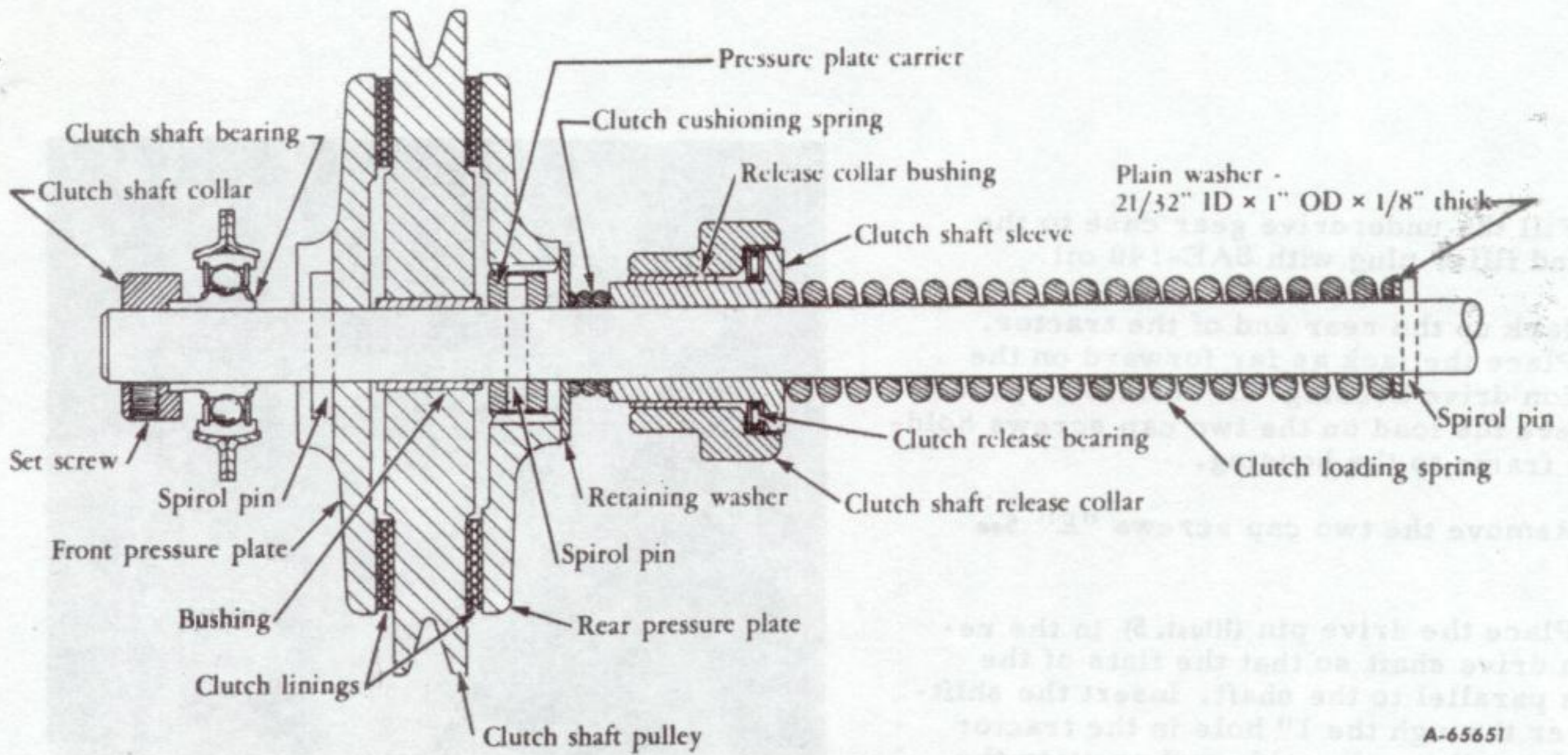

Illustr. 3

3. The parts removed from the shaft are to be installed on the short drive shaft (Illustr. 5) supplied with the underdrive. Assemble in the reverse order of disassembly. See Illustr. 3.

4. Remove the Spirol pin from the coupling arm casting "F" (Illustr. 1). Remove the coupling arm from the tractor reduction drive shaft. Remove the eight cap screws "D" so that the lift lever assembly and foot supports can be swung forward. See Illustr. 1.

5. Cut a 1" hole in the top of the tractor frame 4-3/4" from either side and 2-1/4" forward of the flange. This will allow the underdrive shifting lever to pass through the frame of the tractor. See Illustr. 4.

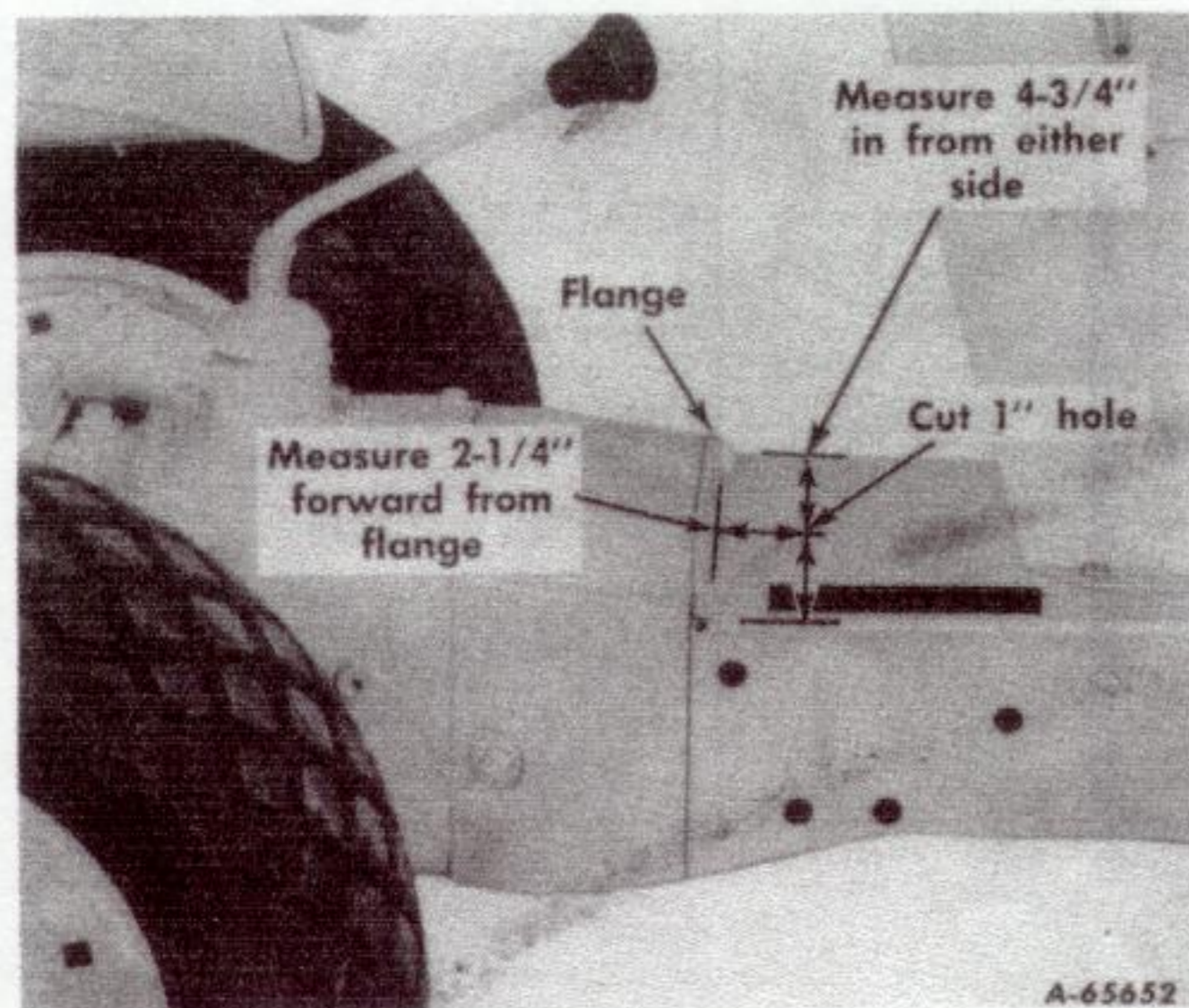

Illustr. 4
Lift lever assembly and foot supports not shown.

6. Mount the coupling arm casting on the input shaft of the underdrive with the 1/4 x 1" Spirol pin. Install the 3/16 x 3/4" Spirol pin in the top hole of the underdrive cap securing the shifting lever. Start the 3/16 x 1/2" Spirol pin in the shifting rod, but do not secure it to the shifting lever at this time. See Illustr. 5.

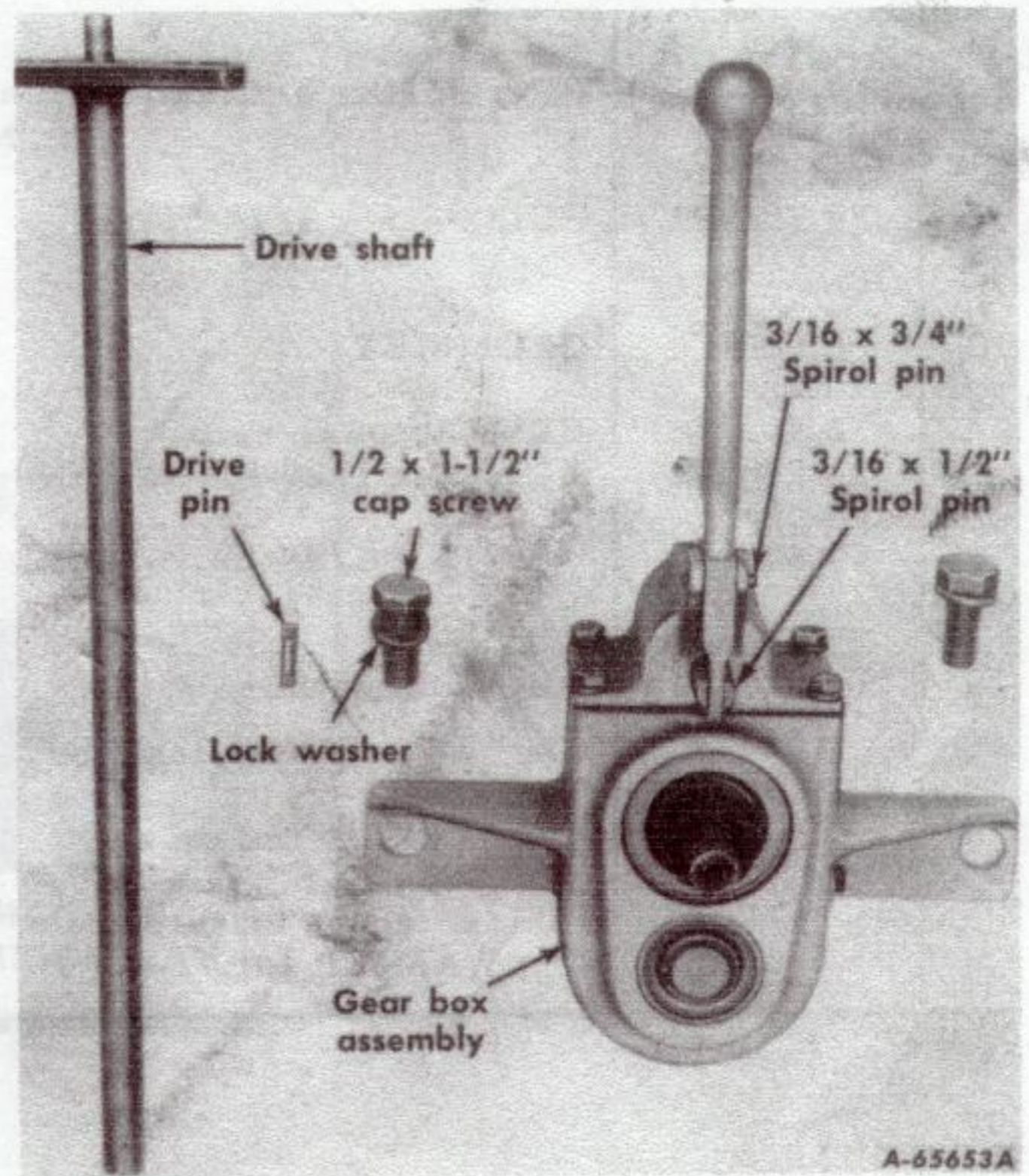

Illustr. 5

7. Fill the underdrive gear case to the level and filler plug with SAE-140 oil.

8. Jack up the rear end of the tractor.
NOTE: Place the jack as far forward on the reduction drive housing "G" (Illust. 1) as possible to relieve the load on the two cap screws holding the frame to the housing.

9. Remove the two cap screws "E" See Illust. 1.

10. Place the drive pin (Illust. 5) in the reduction drive shaft so that the flats of the pin are parallel to the shaft. Insert the shifting lever through the 1" hole in the tractor frame from the under side and position the underdrive so that it will slip over the drive pin. Mount the underdrive with the two 1/2 x 1-1/2" cap screws and lock washers, but do not tighten. **NOTE:** Spin one of the rear wheels so that the underdrive and the reduction drive shaft will center. Tighten the two cap screws alternately and revolve the rear wheel occasionally.

11. Take a pair of pliers and squeeze the 3/16 x 1/2" Spirol pin through the bottom hole in the shifting lever.

12. Replace the lift lever assembly and foot supports; then tighten cap screws "D". See Illust. 1.

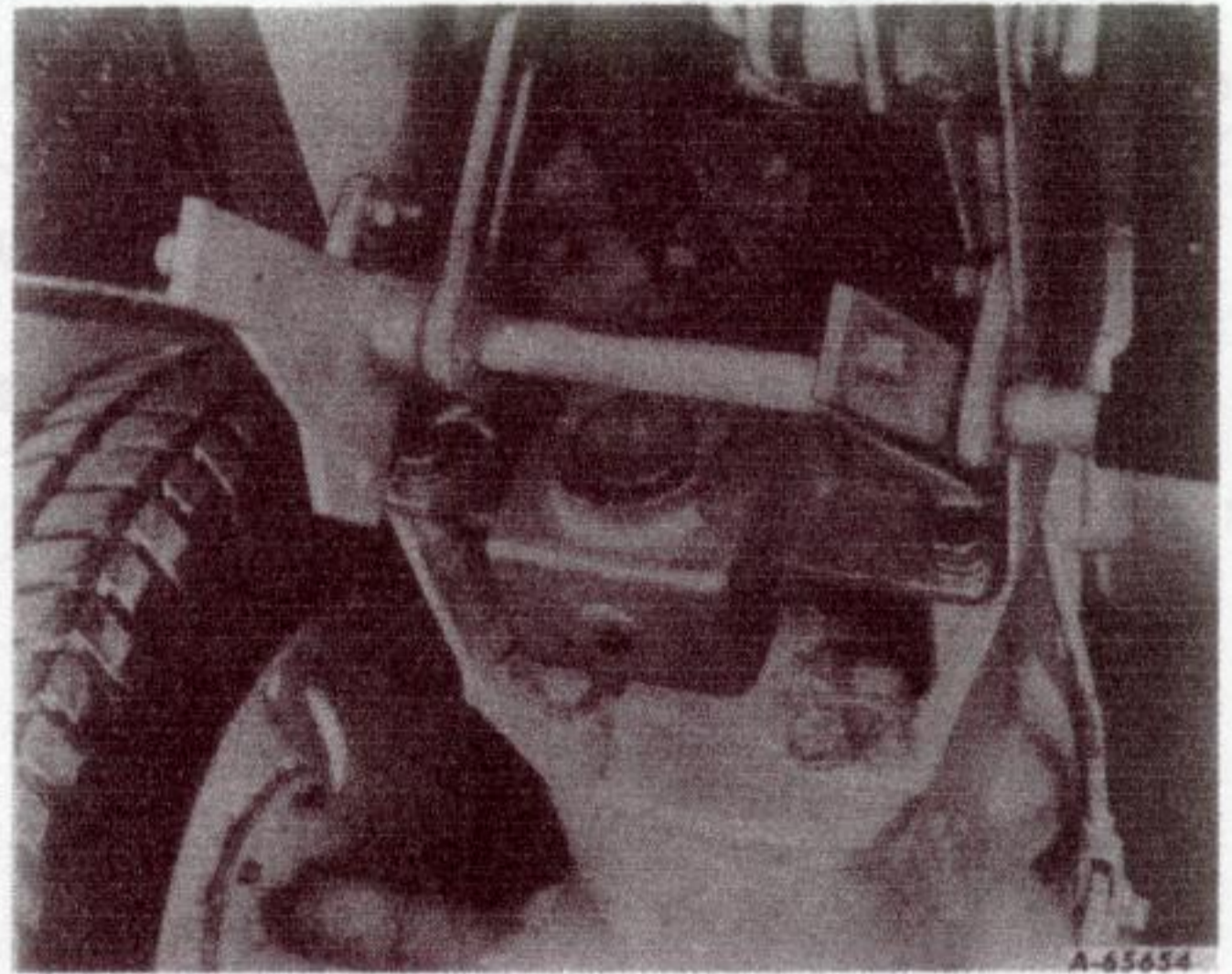

Illust. 6
View showing underdrive unit on tractor.

13. Replace the reassembled clutch and drive belt. Adjust the drive belt and tighten cap screws "A" and "C" (Illust. 1).

14. Replace the clutch operating rod and secure with cotter pin "B".

15. Place the split grommet over the shifting lever and insert it in the drilled hole.

16. Check the clutch and brake adjustments as explained in the Tractor Operator's Manual.



PARTS LIST

UNDERDRIVE

UNDERDRIVE

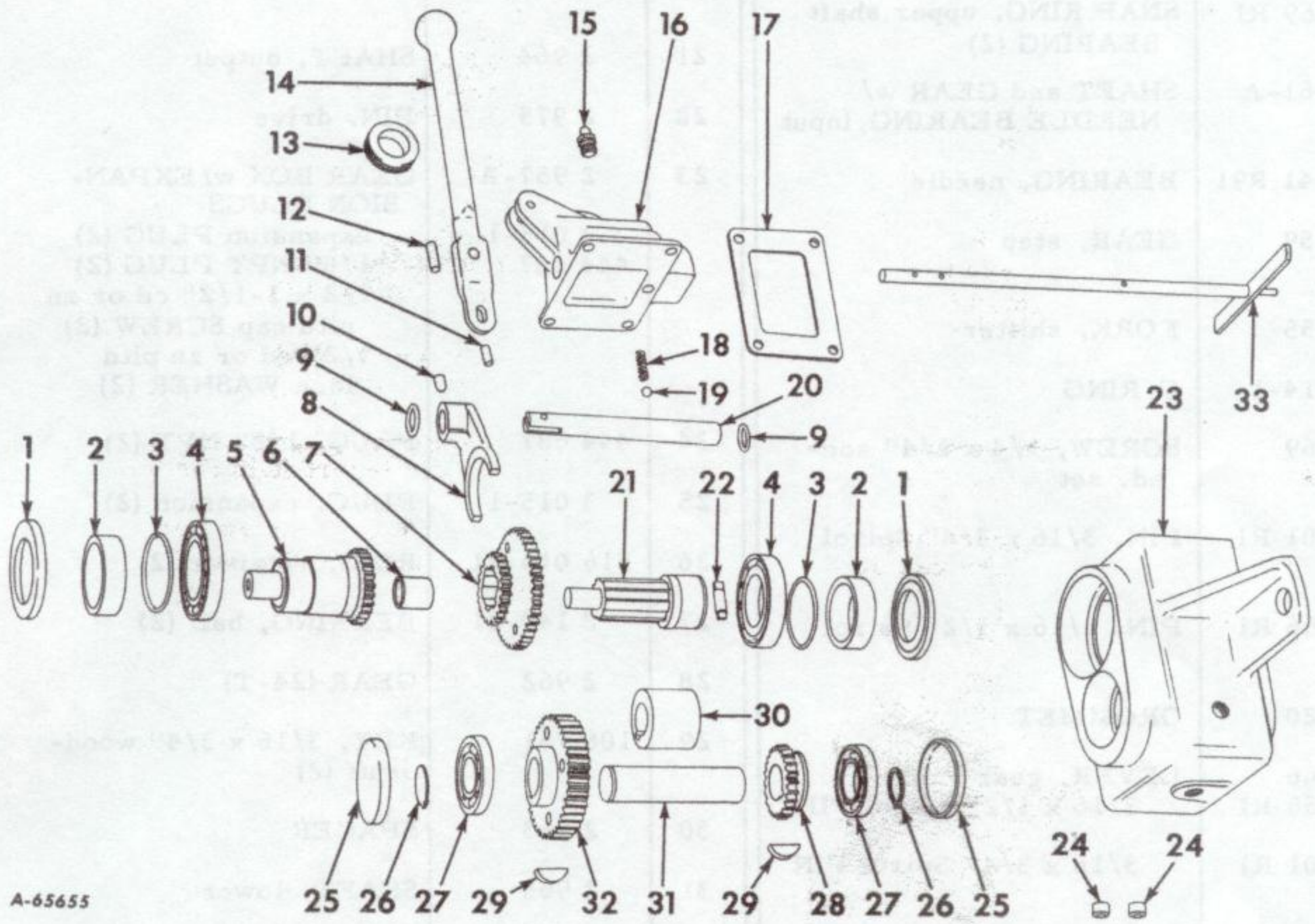

A-65655

PARTS LIST

UNDERDRIVE

Ref. No.	Part Number	Description	Ref. No.	Part Number	Description
1	2 200-24	OIL SEAL (2)	17	2 967	GASKET
2	3 021	COLLAR (2)	18	2 969	SPRING, poppet ball
3	3 014-2	O-RING (2)	19	17 008 R1	BALL (1/4" dia)
4	2 140-20	BEARING, ball (2)	20	2 958	ROD, shifter
—	512 969 R1	SNAP RING, upper shaft BEARING (2)	21	2 964	SHAFT, output
5	2 961-A	SHAFT and GEAR w/ NEEDLE BEARING, input	22	2 975	PIN, drive
6	252 941 R91	BEARING, needle	23	2 957-A	GEAR BOX w/EXPAN- SION PLUGS
7	2 959	GEAR, step		3 015-1	expansion PLUG (2)
8	2 955	FORK, shifter		444 687	1/8" NPT PLUG (2)
9	3 014-1	O-RING			1/2 x 1-1/2" cd or zn pltd cap SCREW (2)
10	102 569	SCREW, 1/4 x 1/4" soc- hd. set	24	444 687	1/2" cd or zn pltd lock WASHER (2)
11	19 801 R1	PIN, 3/16 x 3/4" Spirol	25	3 015-1	PLUG, expansion (2)
12	19 756 R1	PIN, 3/16 x 1/2" Spirol	26	516 010 R1	RING, retainer (2)
13	3 020	GROMMET	27	2 140-21	BEARING, ball (2)
14	2 966	LEVER, gear shift	28	2 962	GEAR (24-T)
	19 756 R1	3/16 x 1/2" Spirol PIN	29	106 751	KEY, 3/16 x 3/4" wood- ruff (2)
	19 801 R1	3/16 x 3/4" Spirol PIN	30	2 963	SPACER
15	13 019 R1	PLUG, breather	31	2 965	SHAFT, lower
16	2 954-A	CAP w/O-RINGS, shifter	32	2 960	GEAR (40-T)
	3 014-1	O-RING (2) 1/4 x 1/2" cd or zn pltd cap SCREW (4) 1/4" cd or zn pltd lock WASHER (4)	33	2 973	SHAFT, clutch