



OPERATOR'S MANUAL

INTERNATIONAL[®] CUB[®] CADET Tractor

INTERNATIONAL HARVESTER COMPANY

180 North Michigan Ave.

Chicago 1, Illinois, U.S.A.

TO THE OWNER

The purpose of this manual is to assist you in realizing the benefits you anticipated when you purchased this International Harvester product. Literally thousands of people have contributed to the design and production of this product and its delivery to you. They have an interest in its successful performance and have provided this manual to give you the benefit of the experience they have gained through years of field testing and normal usage of this and similar products.

The way you operate and the care you give this product will have much to do with its successful performance. This manual has been carefully prepared and the information arranged and illustrated to make it as easy as possible for you to find the information you wish. It will pay you to read the entire manual carefully before operating and keep it handy for future reference. Your International Harvester Dealer will be glad to answer any further questions you may have on the operation or care of this product.

It is the policy of International Harvester Company to improve its products whenever it is possible and practical to do so. We reserve the right to make changes or add improvements at any time without incurring any obligation to make such changes on products sold previously.

All illustrations and descriptive matter in this publication apply to International Harvester products sold under the International, McCormick, McCormick-International, McCormick-Deering, or McCormick-Deering International trade name.

As a member of the National Safety Council, we are privileged to use the Green Cross for Safety to designate not only our interest in Safety, but to point out more clearly the safety precautions in this manual.

Parts Depots are strategically located at 12 points and Transfer Houses at 7 points in the United States. Ample stocks are maintained at all times to assure prompt shipment to your IH dealer to meet your requirements.

Parts Depots in the United States

Albany 1, N. Y.	Broadview, Ill.	Denver 17, Colo.	Portland 8, Oreg.
Atlanta, Ga.	Columbus 16, Ohio	Kansas City 17, Kans.	Richmond 4, Calif.
(East Point, Ga.)	Dallas 22, Tex.	Memphis 6, Tenn.	St. Paul 4, Minn.
Baltimore 3, Md.			

Transfer Houses in the United States

Broadview, Ill.	Kansas City 17, Kans.	Moline, Ill.	Topeka, Kans.
Council Bluffs, Iowa	Memphis 6, Tenn.	St. Paul 14, Minn.	

District Offices in Canada

Calgary, Alta.	Montreal 14, Que.	Regina, Sask.	Vancouver 4, B. C.
Edmonton, Alta.	Ottawa 1, Ont.	Saint John, N. B.	Winnipeg 10, Man.
Hamilton, Ont.	Quebec 8, Que.	Saskatoon, Sask.	Yorkton, Sask.
London, Ont.			

1-14-61.

International Harvester Sales and Service is maintained in all principal countries of the world.

Export address: International Harvester Export Company, Chicago 1, Illinois, U. S. A.

Canadian address: International Harvester Company of Canada, Ltd., Hamilton, Ont., Canada



DELIVERY REPORT

DEALER'S COPY

(This copy to be filed by dealer.)

International Cub Cadet Tractor

Tractor Serial No. _____
(See Illust. 3A)

Engine Serial No. _____
(See Illust. 3B)

Delivered to _____
Purchaser's Name

Address _____
Street and No. or R.F.D. and Box No.

Town _____

State _____

Date _____

19__

Tractor or power equipment being replaced if any:

Make _____ Age _____ (Years) Model _____

Number tractors owned,
including new purchase _____

Check the Major Use Only for this tractor and complete information under heading:

AGRICULTURAL

INDUSTRIAL

1. Type work _____

2. List below equipment to be used with the tractor:

Equipment _____

Equipment _____

Make _____ Model _____

Make _____ Model _____

Equipment _____

Equipment _____

Make _____ Model _____

Make _____ Model _____

PREDELIVERY SERVICE—Prior to delivery of the above tractor the following checks and tests were made and corrective action taken as necessary:

- Shortage or Damage in Shipment
- Extra Equipment and Accessories Checked Against Purchase Order
- Tire Pressures
- Engine Oil Level
- Air Cleaner Oil Level
- Transmission, Differential, and Reduction Drive Oil Level

- Water Level and Gravity of Battery Checked When Installed*
- Motor—Generator*
- Clutch
- Brake
- Drive Belt
- Torque Cylinder Head—Engine Hot

- Engine Operation
- Gear Shifting—All Speeds
- Road Test for General Operation
- Clean and Polish

DELIVERY SERVICE—At time of delivery the importance of the Operator's Manual was explained and, with it as a guide, instruction was given as indicated by check marks:

- Precautions with New Tractor
- Lubricating Entire Tractor
- Fuel and Lubricant Specifications
- Checking Oil Levels
- Care of Air Cleaner and Breathers
- Starting, Stopping, and General Operation
- Safe Hitching Practices
- Care of Cooling System

- Care of Fuel System
- Adjustment of Clutch
- Care of Ignition System*
- Care of Motor—Generator*
- Care of Battery*
- Adjustment of Brake
- Tires—Inflation, Weighting, Care
- Wheel Weights
- Cold Weather Operation

- Storing Tractor
- Starting Tractor After Storage
- Caution Regarding High-Speed Operation
- Tightening Nuts and Bolts
- Keeping Tractor Clean
- Annual Tractor Service Plan Agreement

*When So Equipped.

The customer's signature below certifies that the tractor was delivered to him in a satisfactory condition and that he received instruction as to its proper operation and maintenance.

Appointment for after-delivery inspection (10 to 30 days after) was made for _____ Date _____

Signed _____
Customer

Signed _____
Dealer

By _____

By _____



DELIVERY REPORT

DISTRICT OFFICE COPY

(This copy to be sent to International Harvester District Office.)
(EXPORT—Send to Distributor or Affiliate General Office.)

(EXPORT—DISTRIBUTOR OR
AFFILIATE OFFICE COPY)

FOR ENGINE MANUFACTURER

International Cub Cadet Tractor

Tractor Serial No. _____
(See Illust. 3A)

Engine Serial No. _____
(See Illust. 3B)

Delivered to _____
Purchaser's Name

Address _____
Street and No. or R.F.D. and Box No.

_____ Town

_____ State _____ Date _____ 19____

Tractor or power equipment being replaced if any:

Make _____ Age _____ (Years)

Model _____

Number tractors owned,
including new purchase _____

Check the Major Use Only for this tractor and complete information under heading:

AGRICULTURAL

INDUSTRIAL

1. Type work _____

2. List below equipment to be used with the tractor:

Equipment _____

Equipment _____

Make _____ Model _____

Make _____ Model _____

Equipment _____

Equipment _____

Make _____ Model _____

Make _____ Model _____

PREDELIVERY SERVICE—Prior to delivery of the above tractor the following checks and tests were made and corrective action taken as necessary:

- Shortage or Damage in Shipment
- Extra Equipment and Accessories Checked Against Purchase Order
- Tire Pressures
- Engine Oil Level
- Air Cleaner Oil Level
- Transmission, Differential, and Reduction Drive Oil Level

- Water Level and Gravity of Battery Checked When Installed*
- Motor—Generator*
- Clutch
- Brake
- Drive Belt
- Torque Cylinder Head—Engine Hot

- Engine Operation
- Gear Shifting—All Speeds
- Road Test for General Operation
- Clean and Polish

DELIVERY SERVICE—At time of delivery the importance of the Operator's Manual was explained and, with it as a guide, instruction was given as indicated by check marks:

- Precautions with New Tractor
- Lubricating Entire Tractor
- Fuel and Lubricant Specifications
- Checking Oil Levels
- Care of Air Cleaner and Breathers
- Starting, Stopping, and General Operation
- Safe Hitching Practices
- Care of Cooling System

- Care of Fuel System
- Adjustment of Clutch
- Care of Ignition System*
- Care of Motor—Generator*
- Care of Battery*
- Adjustment of Brake
- Tires—Inflation, Weighting, Care
- Wheel Weights
- Cold Weather Operation

- Storing Tractor
- Starting Tractor After Storage
- Caution Regarding High-Speed Operation
- Tightening Nuts and Bolts
- Keeping Tractor Clean
- Annual Tractor Service Plan Agreement

*When So Equipped.

The customer's signature below certifies that the tractor was delivered to him in a satisfactory condition and that he received instruction as to its proper operation and maintenance.

Appointment for after-delivery inspection (10 to 30 days after) was made for _____ Date _____

Signed _____
Customer

Signed _____
Dealer

By _____

By _____



DELIVERY REPORT

(This copy to be sent to International Harvester District Office.)
(EXPORT—Send to Distributor or Affiliate General Office.)

DISTRICT OFFICE COPY
(EXPORT—DISTRIBUTOR OR
AFFILIATE OFFICE COPY)

FOR ENGINE MANUFACTURER

International Cub Cadet Tractor

Tractor Serial No. _____
(See Illust. 3A)

Engine Serial No. _____
(See Illust. 3B)

Delivered to _____
Purchaser's Name

Address _____
Street and No. or R.F.D. and Box No.

_____ Town _____

_____ State _____ Date _____ 19____

Tractor or power equipment being replaced if any:

Make _____ Age _____ (Years)

Model _____

Number tractors owned,
including new purchase _____

Check the Major Use Only for this tractor and complete information under heading:

AGRICULTURAL

INDUSTRIAL

1. Type work _____

2. List below equipment to be used with the tractor:

Equipment _____

Equipment _____

Make _____ Model _____

Make _____ Model _____

Equipment _____

Equipment _____

Make _____ Model _____

Make _____ Model _____

PREDELIVERY SERVICE—Prior to delivery of the above tractor the following checks and tests were made and corrective action taken as necessary:

- Shortage or Damage in Shipment
- Extra Equipment and Accessories Checked Against Purchase Order
- Tire Pressures
- Engine Oil Level
- Air Cleaner Oil Level
- Transmission, Differential, and Reduction Drive Oil Level

- Water Level and Gravity of Battery Checked When Installed*
- Motor—Generator*
- Clutch
- Brake
- Drive Belt
- Torque Cylinder Head—Engine Hot

- Engine Operation
- Gear Shifting—All Speeds
- Road Test for General Operation
- Clean and Polish

DELIVERY SERVICE—At time of delivery the importance of the Operator's Manual was explained and, with it as a guide, instruction was given as indicated by check marks:

- Precautions with New Tractor
- Lubricating Entire Tractor
- Fuel and Lubricant Specifications
- Checking Oil Levels
- Care of Air Cleaner and Breathers
- Starting, Stopping, and General Operation
- Safe Hitching Practices
- Care of Cooling System

- Care of Fuel System
- Adjustment of Clutch
- Care of Ignition System*
- Care of Motor—Generator*
- Care of Battery*
- Adjustment of Brake
- Tires—Inflation, Weighting, Care
- Wheel Weights
- Cold Weather Operation

- Storing Tractor
- Starting Tractor After Storage
- Caution Regarding High-Speed Operation
- Tightening Nuts and Bolts
- Keeping Tractor Clean
- Annual Tractor Service Plan Agreement

**When So Equipped.*

The customer's signature below certifies that the tractor was delivered to him in a satisfactory condition and that he received instruction as to its proper operation and maintenance.

Appointment for after-delivery inspection (10 to 30 days after) was made for _____ Date _____

Signed _____ Customer

Signed _____ Dealer

By _____

By _____



DELIVERY REPORT

OWNER'S COPY

(This copy to be retained by owner.)

International Cub Cadet Tractor

Tractor Serial No. _____
(See Illust. 3A)

Engine Serial No. _____
(See Illust. 3B)

Delivered to _____
Purchaser's Name

Address _____
Street and No. or R.F.D. and Box No.

_____ Town

State

Date

19__

Tractor or power equipment being replaced if any:

Make _____ Age _____ (Years)

Model _____

Number tractors owned,
including new purchase _____

Check the Major Use Only for this tractor and complete information under heading:

AGRICULTURAL

INDUSTRIAL

1. Type work _____

2. List below equipment to be used with the tractor:

Equipment _____

Equipment _____

Make _____ Model _____

Make _____ Model _____

Equipment _____

Equipment _____

Make _____ Model _____

Make _____ Model _____

PREDELIVERY SERVICE—Prior to delivery of the above tractor the following checks and tests were made and corrective action taken as necessary:

- Shortage or Damage in Shipment
- Extra Equipment and Accessories Checked Against Purchase Order
- Tire Pressures
- Engine Oil Level
- Air Cleaner Oil Level
- Transmission, Differential, and Reduction Drive Oil Level

- Water Level and Gravity of Battery Checked When Installed*
- Motor—Generator*
- Clutch
- Brake
- Drive Belt
- Torque Cylinder Head—Engine Hot

- Engine Operation
- Gear Shifting—All Speeds
- Road Test for General Operation
- Clean and Polish

DELIVERY SERVICE—At time of delivery the importance of the Operator's Manual was explained and, with it as a guide, instruction was given as indicated by check marks:

- Precautions with New Tractor
- Lubricating Entire Tractor
- Fuel and Lubricant Specifications
- Checking Oil Levels
- Care of Air Cleaner and Breathers
- Starting, Stopping, and General Operation
- Safe Hitching Practices
- Care of Cooling System

- Care of Fuel System
- Adjustment of Clutch
- Care of Ignition System*
- Care of Motor—Generator*
- Care of Battery*
- Adjustment of Brake
- Tires—Inflation, Weighting, Care
- Wheel Weights
- Cold Weather Operation

- Storing Tractor
- Starting Tractor After Storage
- Caution Regarding High-Speed Operation
- Tightening Nuts and Bolts
- Keeping Tractor Clean
- Annual Tractor Service Plan Agreement

*When So Equipped.

The customer's signature below certifies that the tractor was delivered to him in a satisfactory condition and that he received instruction as to its proper operation and maintenance.

Appointment for after-delivery inspection (10 to 30 days after) was made for _____ Date _____

Signed _____
Customer

Signed _____
Dealer

By _____

By _____



CONTENTS

International Cab Cabet tractor

Description	Page No.
INTRODUCTION	
Delivery Report (to be filled in when tractor is delivered)	Inside Front Cover
Orientation	3
Serial numbers, engine and tractor	3
DESCRIPTION	
Instruments and controls	5,6
Views of the tractor	4
OPERATION	
Before starting the tractor	7
Driving the tractor	9, 10
Hitching an implement to the tractor	10
Operating the engine	7 to 9
LUBRICATION	
Lubrication	11
Lubrication guide	12, 13
Lubrication table	11
MAINTENANCE	
Air cleaner	16
Breaker points and spark plug	21
Carburetor	15
Clutch and brake	17, 18
Cooling system	16
Drive belt	19, 20
Electric starting equipment	22, 23
Fuel strainer	16
Motor-generator belt	20
Periodic inspections	14
Pneumatic tires	16
Starting engines that have been in storage	24
Storage battery	23
Storing and housing your tractor	24
Trouble shooting	25
Wheels	17
SPECIFICATIONS	
Index	26
	27

INTRODUCTION

Assembled in this book are operating and maintenance instructions for the International Cub Cadet Tractor. This material has been prepared in detail in the hope that it will help you to better understand the correct care and efficient operation of your tractor.

If you should need information not given in this manual, or require the services of a trained mechanic, get in touch with the International Harvester dealer in your locality. Dealers are kept informed on the latest methods of servicing tractors. They carry stocks of IH parts, and are backed in every case by the full facilities of a nearby International Harvester District Office.

Throughout this manual the use of the terms LEFT, RIGHT, FRONT, and REAR must be understood to avoid confusion when following instructions. LEFT and RIGHT indicate the left and right sides of the tractor when facing forward in the driver's seat. Reference to FRONT indicates the grille end of the tractor; to REAR, the drawbar end. See *Illust. 3*.

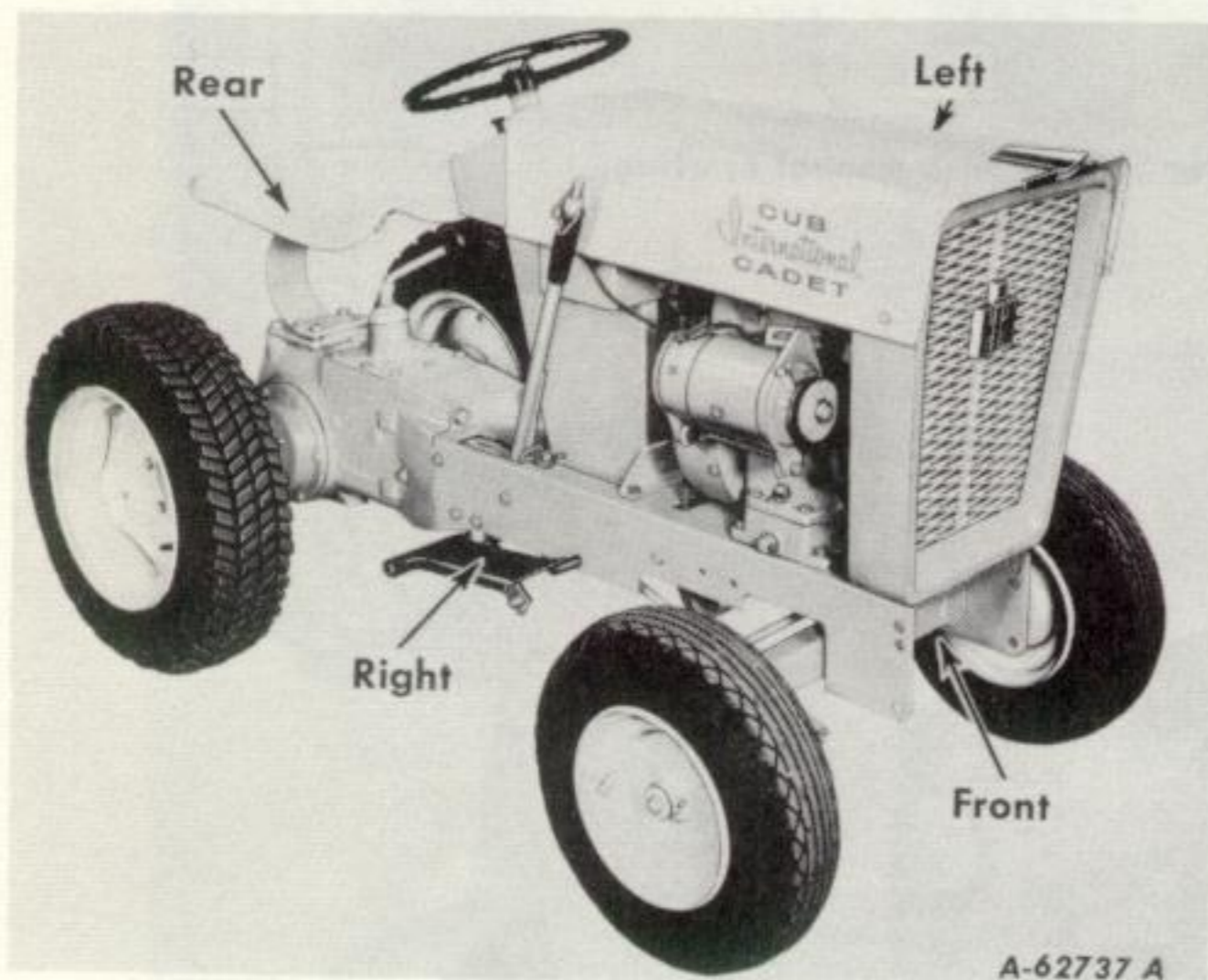

Illust. 3
Terms of location.

The illustrations in this manual are numbered to correspond with the pages on which they appear; for example, *Illusts. 3, 3A and 3B* are on page 3.

In order to provide a tractor equipped as nearly as possible to suit each customer's needs, extra equipment is available.

Where operating or maintaining instruction on these items is required, it is included in this manual. Disregard the instructions for equipment not on your tractor.

When in need of parts, always specify the tractor and engine serial numbers. The tractor serial number is stamped on the reduction gear housing on the right side of the tractor. See *Illust. 3A*.

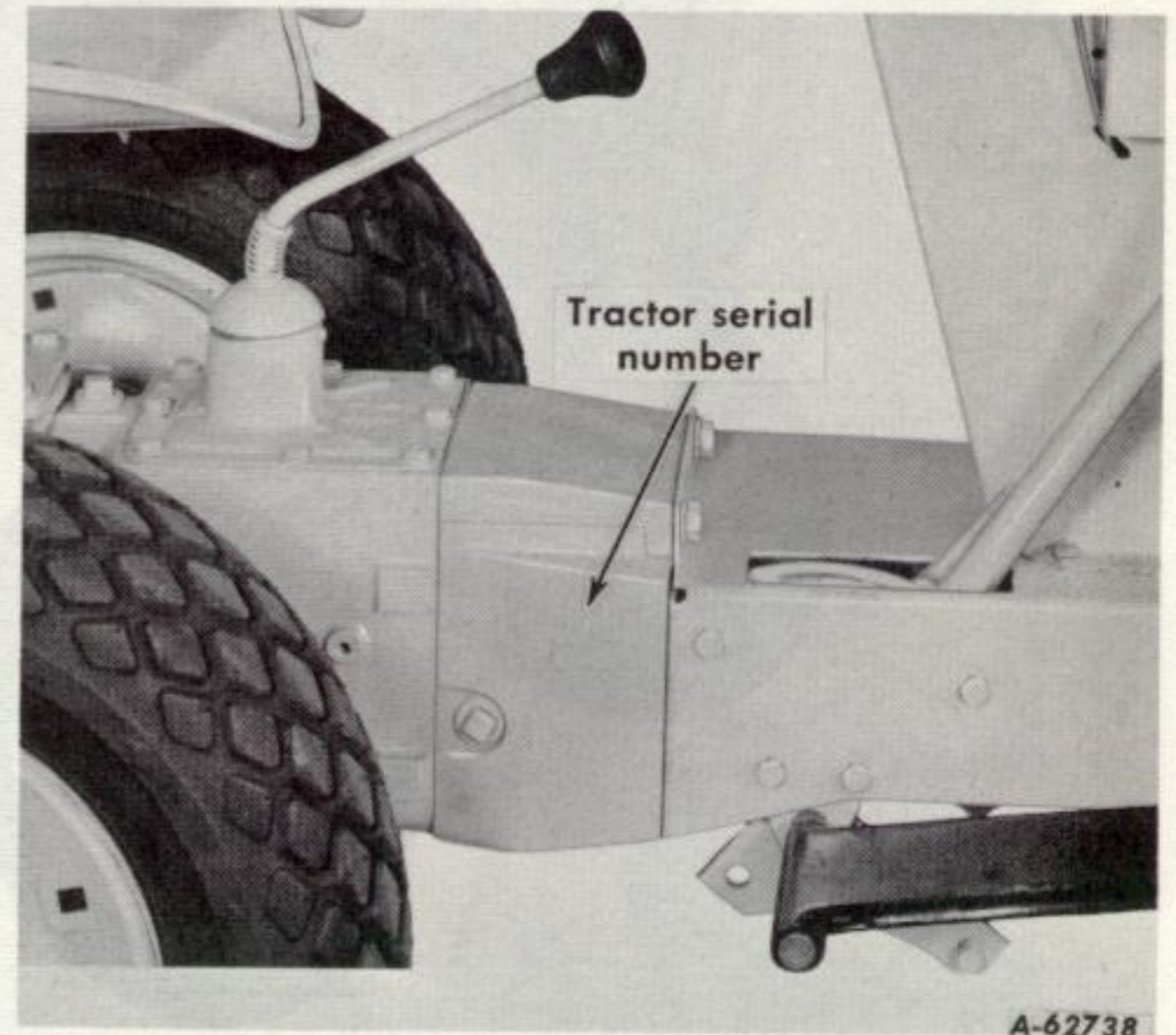

Illust. 3A
Location of tractor serial number.

The engine serial number is stamped on a plate on the left side of the engine. See *Illust. 3B*.

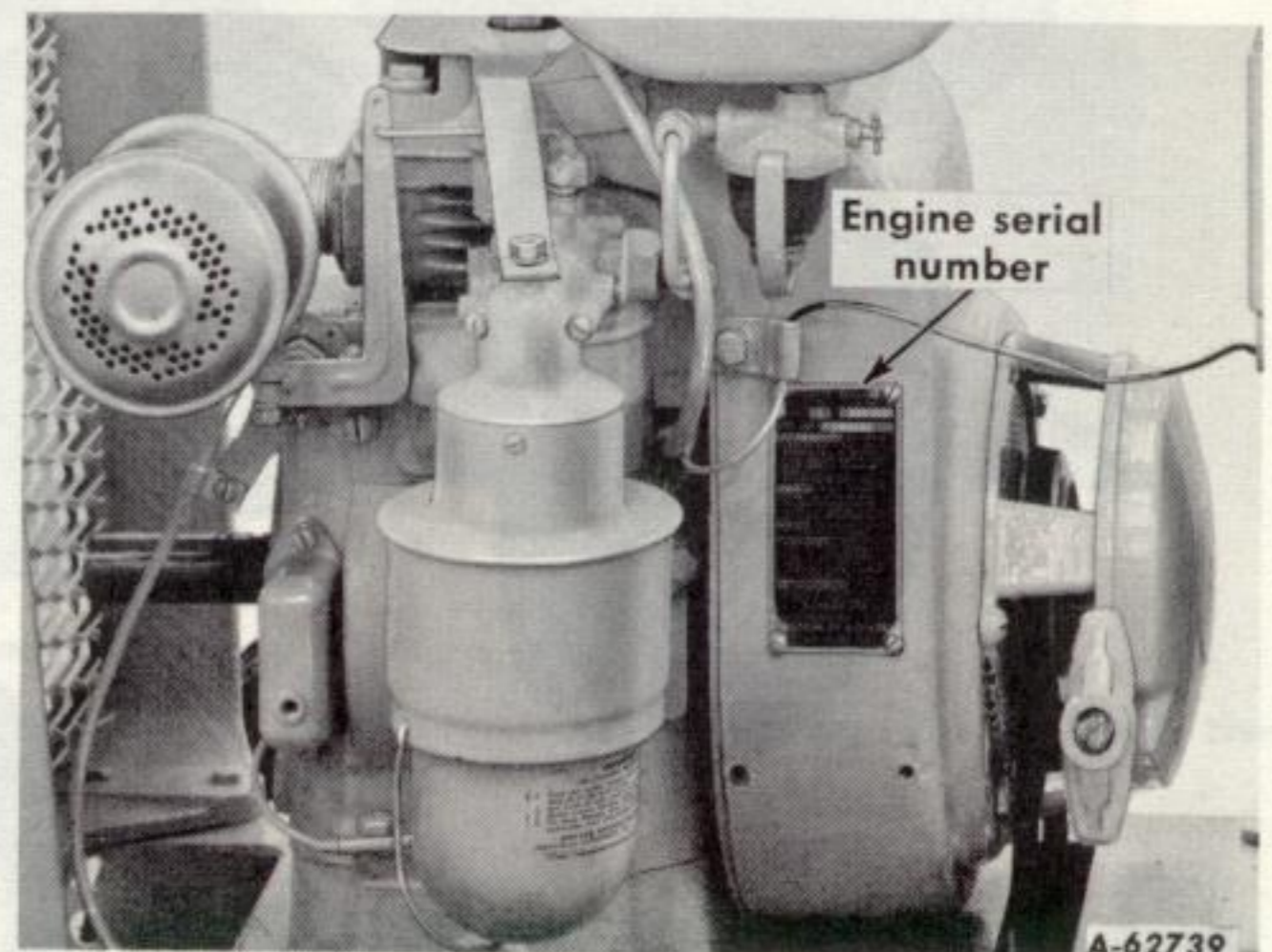

Illust. 3B
Location of engine serial number.

For ready reference, we suggest that you write these serial numbers in the spaces provided on the Delivery Report.

DESCRIPTION

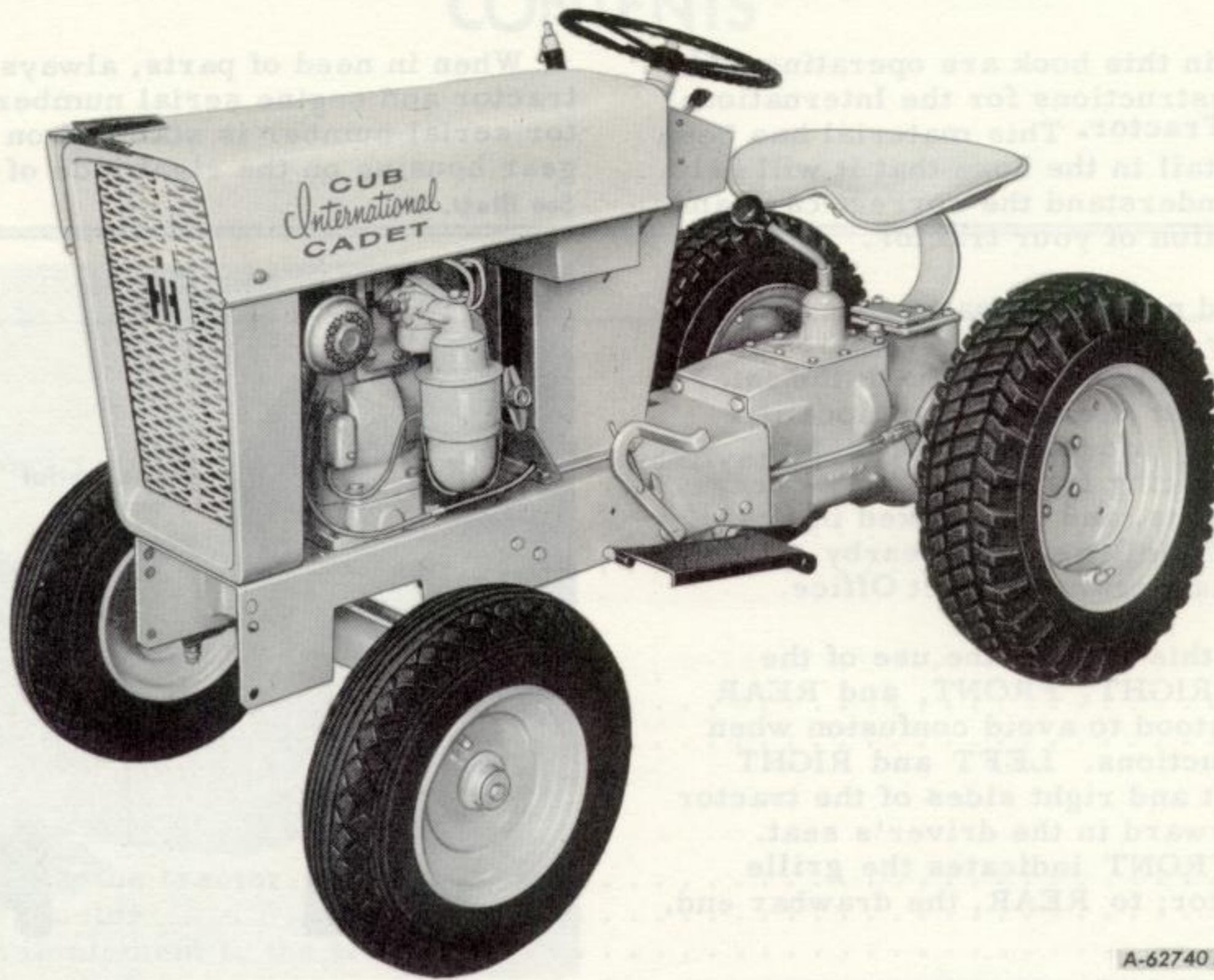

A-62740 A

Illust. 4
Left front view of International Cub Cadet Tractor with manual starting.

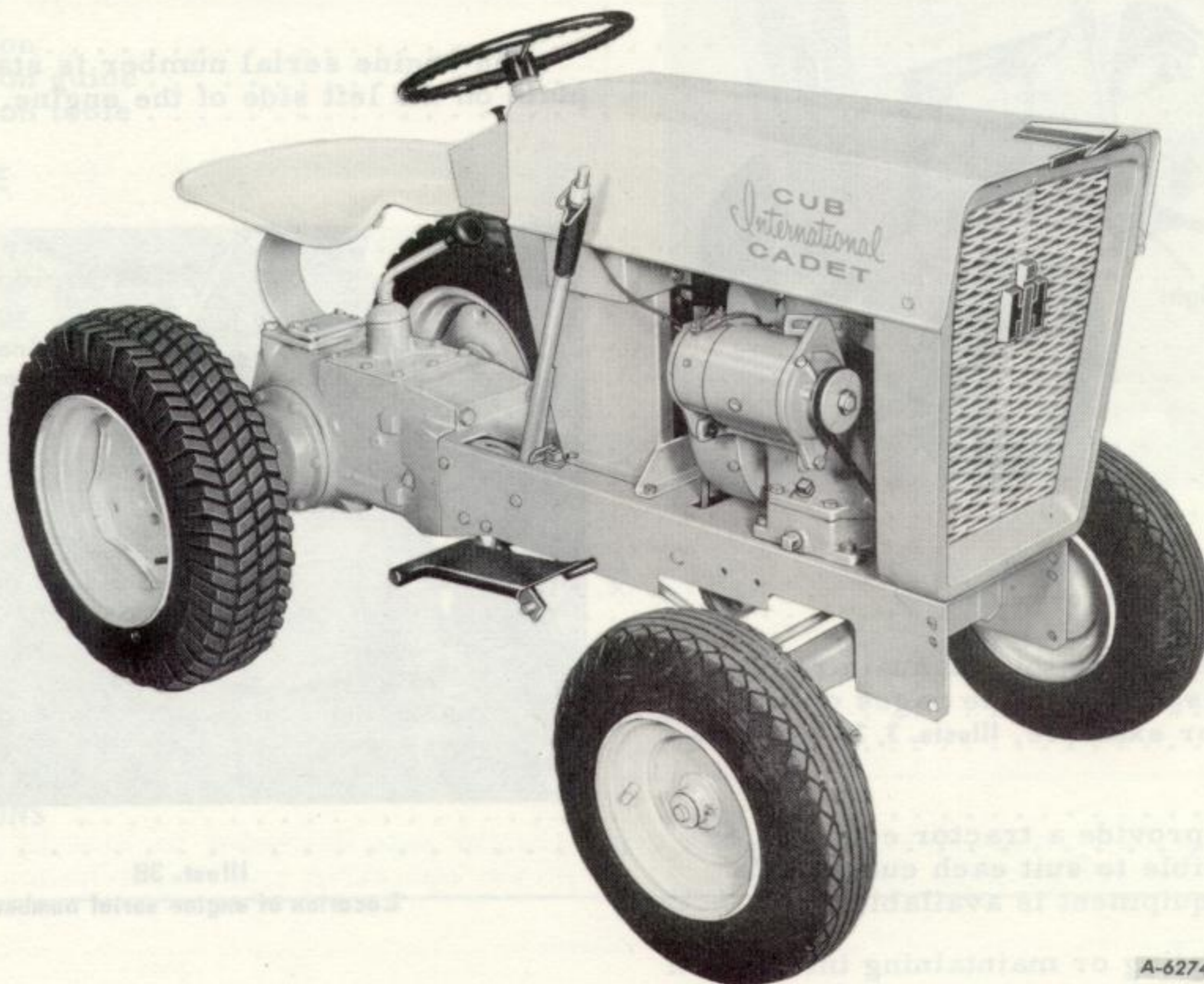

A-62741 A

Illust. 4A
Right front view of International Cub Cadet Tractor with electric starting.

DESCRIPTION

Instruments and Controls

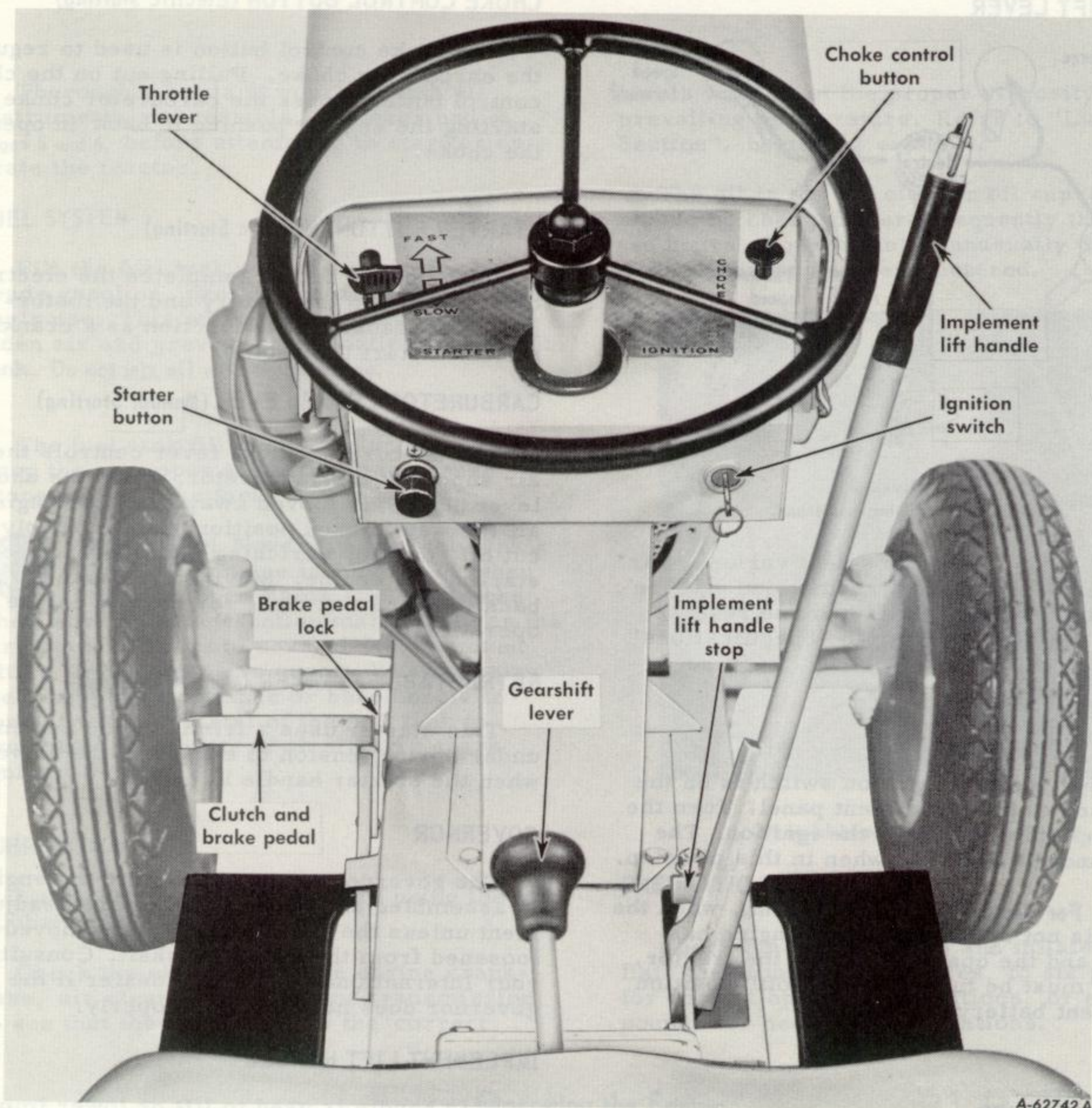

Illust. 5
Instruments and controls.

LIFTING THE HOOD

The tractor hood is arranged to swing up and forward to make the engine and fuel tank readily accessible.

To raise the hood, take hold of each side of the hood at the rear, pull outward, and raise it upward and forward to its stop.

CLUTCH AND BRAKE PEDAL

The combination clutch and brake pedal is used to disengage the engine from the trans-

mission when shifting gear and to actuate the brake to stop the tractor.

To disengage the clutch, press the pedal half way down. To stop the tractor press the pedal all the way down.

The brake pedal lock is used to lock the brake pedal in the depressed position. This keeps the tractor from moving.

DESCRIPTION

Instruments and Controls

GEARSHIFT LEVER

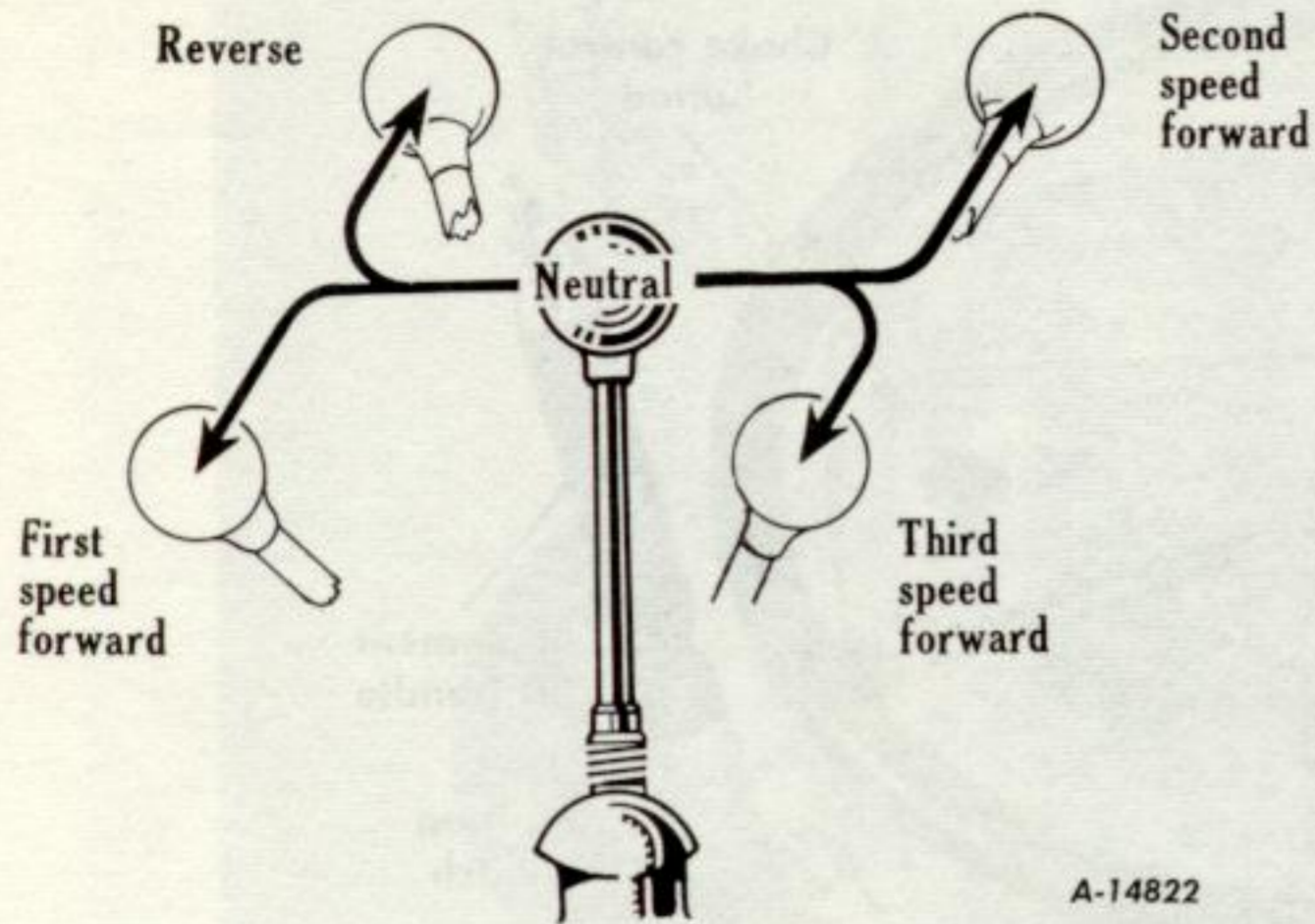

Illustr. 6
Gear shifting positions.

This lever is used to select various gear ratios provided in the transmission. There are three forward speeds and one reverse speed. See Illustr. 6. Refer to "Specifications" on page 26.

IGNITION SWITCH

A key-type lock ignition switch is on the right side of the instrument panel. Turn the key clockwise to turn on the ignition. The key cannot be removed when in this position.

Note: For tractors with electric starting, when the engine is not operating or the engine has stalled and the operator leaves the tractor, the key must be turned to the "off" position to prevent battery discharge.

THROTTLE LEVER

This lever (on the left side of the instrument panel) controls the speed of the engine and, when set in a given position, will maintain a uniform engine speed.

When the lever is set at the bottom position ("Slow"), the engine speed is fully retarded and when the lever is at the top position ("Fast"), the engine speed is fully advanced.

CHOKE CONTROL BUTTON (Electric Starting)

The choke control button is used to regulate the carburetor choke. Pulling out on the choke control button closes the carburetor choke for starting the engine; pushing it back in opens the choke.

STARTER BUTTON (Electric Starting)

Pushing this button completes the electrical circuit between the battery and the motor-generator causing it to function as a cranking motor to start the engine.

CARBURETOR CHOKE LEVER (Manual Starting)

The carburetor choke lever controls the air supply to the carburetor. When the choke lever (Illustr. 9) is moved away from the engine all the way (closed position) the air supply is cut off, thereby enriching the fuel mixture for starting the engine. Moving the choke lever back in opens the choke for normal engine operation.

RETRACTABLE STARTER (Manual Starting)

This starter uses a friction shoe assembly under spring tension to engage in the drive cup when the starter handle is pulled.

GOVERNOR

The governor is set at the time the engine is assembled and should not require readjustment unless the governor arm is removed or loosened from the governor shaft. Consult your International Harvester dealer if the governor does not function properly.

IMPLEMENT LIFT HANDLE

This handle is used to lift or lower implements used with the tractor. Depress the release button to move the handle.

When operating an implement in the "float" position, depress the release button and move the wire bail over the top of the button.

An adjustable stop limits the travel of the implement handle to control the lowering of the implement when "free-to-float". See Illustr. 10B.

OPERATION

Before Starting the Tractor

Thoroughly acquaint yourself with all instruments and controls, as described on pages 5 and 6, before attempting to start or operate the tractor.

FUEL SYSTEM

Fill the fuel tank with clean, fresh, regular grade gasoline, preferably at the end of each day's use. This will force out any moisture-laden air and prevent condensation in the fuel tank. Do not mix oil with the gasoline.

The fuel tank filler cap has an air vent. Keep the vent open at all times to assure proper flow of the fuel.



Safety First! Never fill the fuel tank when the engine is running or when near an open flame. Do not smoke when working around inflammable fuel, as the air within a radius of several feet is mixed with a highly explosive vapor. When pouring fuel, keep the container or hose nozzle in contact with the metal of the fuel tank to avoid the possibility of an electric spark igniting the gas.

LUBRICATION

Lubricate the entire tractor, using the "Lubrication Guide".

Check the oil levels of the engine crankcase, air cleaner oil cup, and transmission to see that they are filled to the correct

FUEL SHUT-OFF VALVE

Be sure the shut-off valve on the fuel strainer under the gasoline tank is open. To prevent leakage or seepage when the valve is in its full-open position, screw out the needle stem (shut-off valve) until the seat on the stem is tight against the stop.

levels with oil of the proper viscosity for the prevailing temperature. Refer to "Lubrication Section", beginning on page 11.

The oil in the air cleaner oil cup (Illustr. 7) should be changed more frequently than every ten hours of operation, if unusually dusty and dirty conditions are encountered.

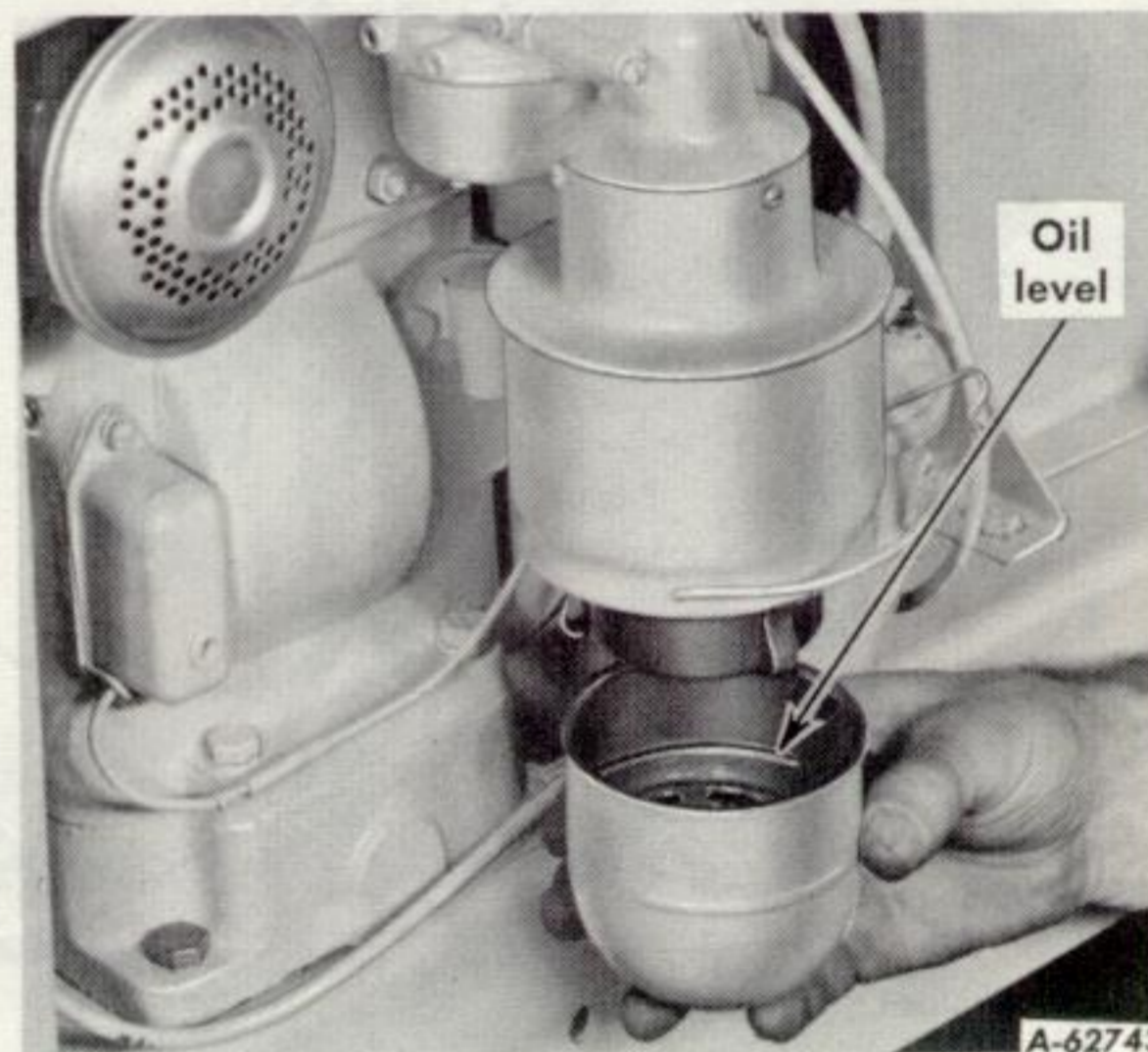

Illustr. 7
Oil level bead in air cleaner oil cup.

PNEUMATIC TIRES

Check the air pressure and inflate or deflate the front and rear tires, to six pounds for normal operating conditions, or eight pounds for heavy load operations.

Operating the Engine

STARTING THE ENGINE (With Electric Starting)

1. Put the gearshift lever in the neutral position. See Illustr. 6.
2. Pull the choke control button all the way out (see Illustr. 8). More or less choking may be necessary due to variations in temperature, grade of fuel, etc. Little or none will be needed when the engine is warm.

OPERATION

Operating the Engine

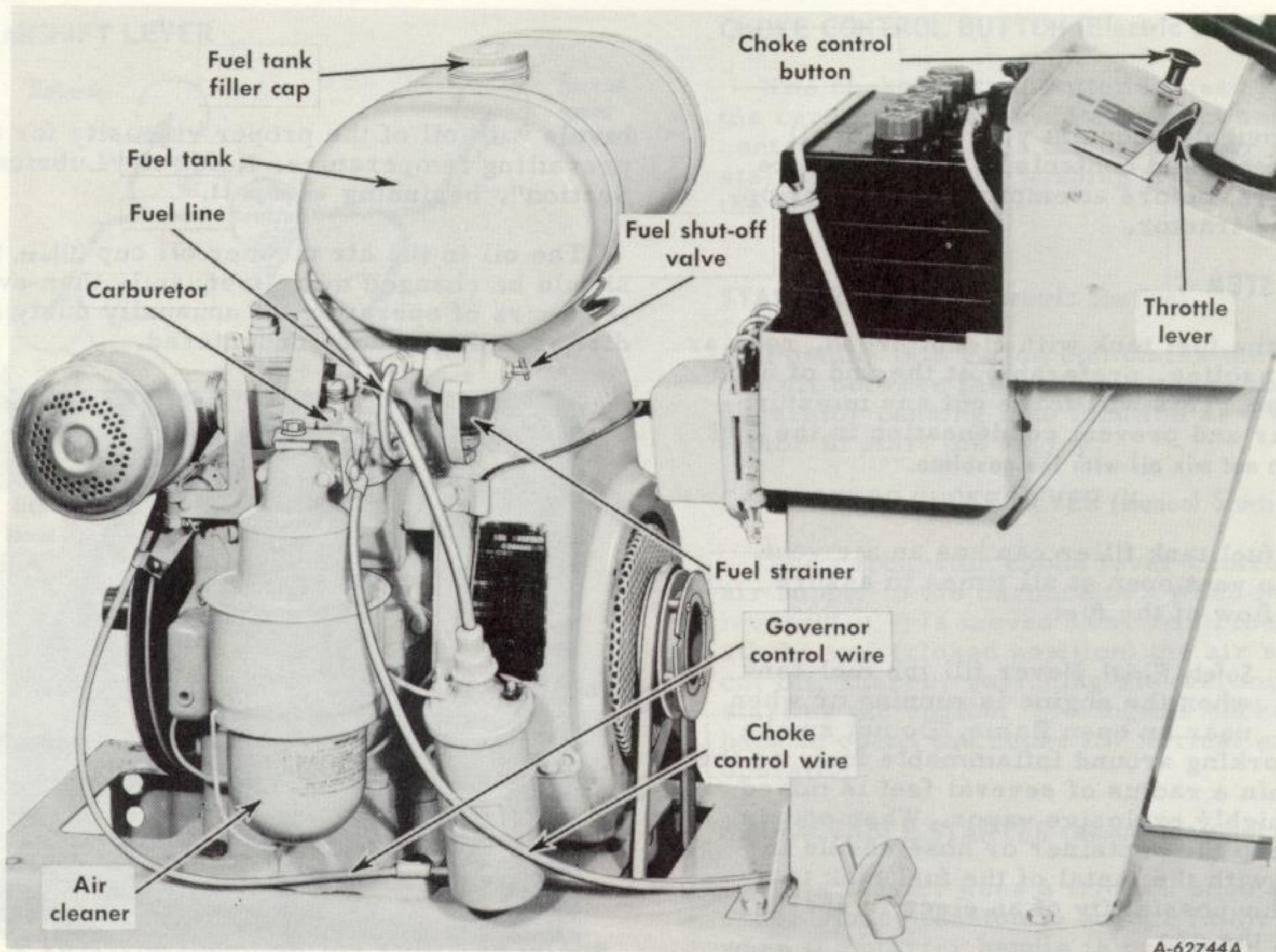

Illust. 8
Fuel system and controls.

3. Place the throttle lever halfway between "Slow" and "Fast". See Illust. 8.

4. Disengage the clutch by pressing the clutch and brake pedal halfway down.

5. Turn the ignition switch clockwise to the horizontal position. Press the starter button (Illust. 5) and release it as soon as the engine starts; however, do not operate the motor-generator for more than 30 seconds at any one time. If the engine does not start within this time, release the starter button and wait a minute or two; then try again.

6. Slowly release the clutch pedal after the engine starts and gradually push the choke control button all the way in. Do not use the choke to enrich the fuel mixture, except when necessary to start the engine.

STARTING THE ENGINE (With Manual Starting)

1. Put the gear shift lever in the neutral position and lock the brake. See Illust. 6.

2. Place the throttle lever halfway between "Slow" and "Fast". See Illust. 8.

3. Turn the ignition switch clockwise.

4. Move the carburetor choke lever to the "choke" position (away from the engine). See Illust. 9. More or less choking may be necessary due to variations in temperature, grade of fuel, etc. Little or none will be needed when the engine is warm.

5. Give a quick steady pull on the retractable starter handle to start the engine. Do not

OPERATION

Operating the Engine

STOPPING THE TRACTOR

jerk or pull it out to its very end in a rough manner. A steady pull will accomplish just as much. Always pull the handle so the cord is in a straight line through the guide. Maintain your hold on the handle and allow the cord to return slowly. Releasing the handle when the cable is extended will shorten the life of the starter.

6. Slowly return the carburetor choke lever to its "open" position immediately after the engine has started.

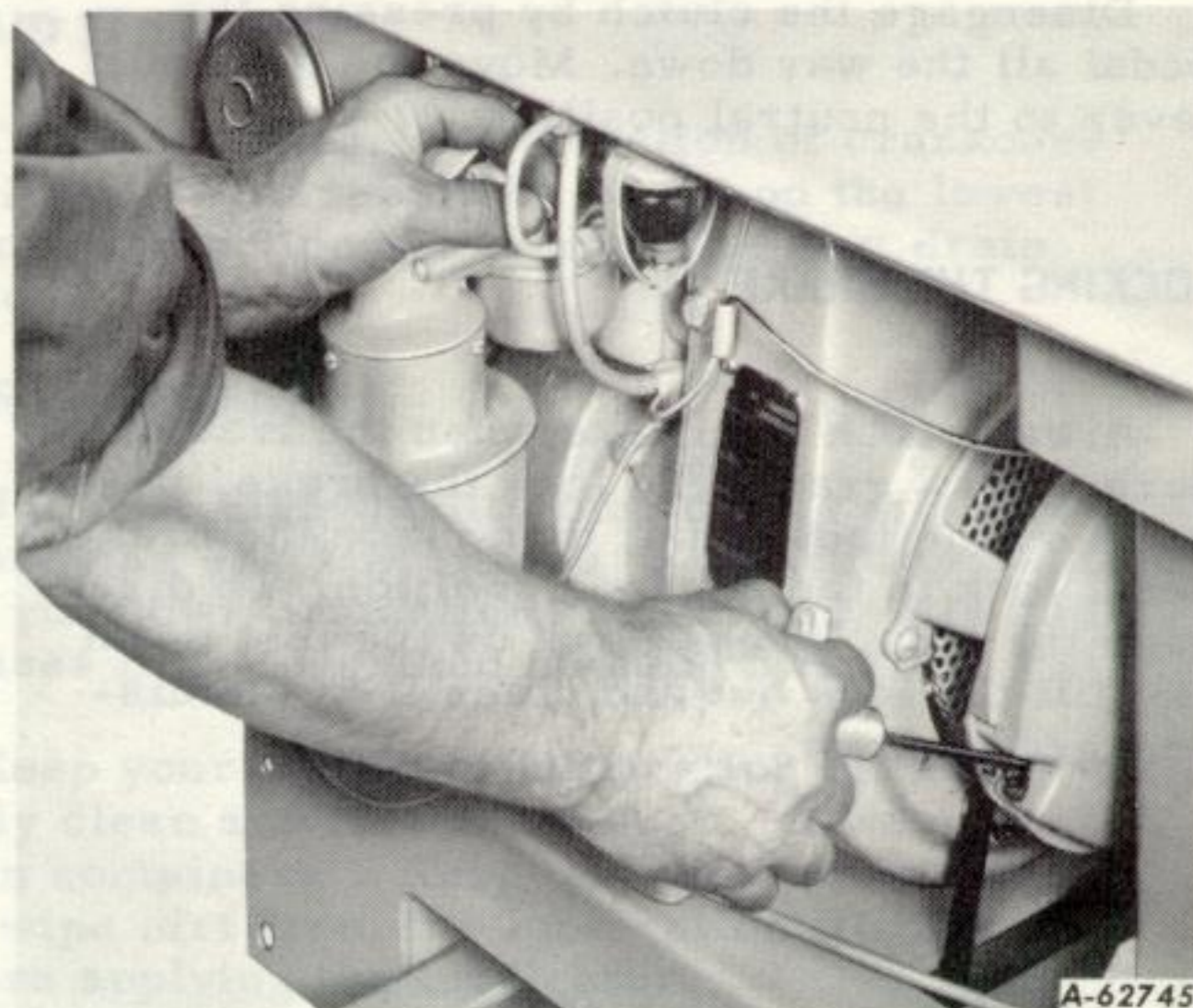

Illust. 9
Closing the carburetor choke lever
(Tractors with manual starting).

STOPPING THE ENGINE

Move the throttle lever to the "slow" position and allow the engine to idle for a short time before stopping. Then turn the key to the "off" position.

Driving the Tractor

ADJUSTING THE SEAT

The tractor seat can be set in one of three positions by removing the seat and placing the bolt in a different hole in the seat support bracket. See Illust. 9A.



Illust. 9A
Adjusting the seat.

STARTING THE TRACTOR

1. Advance the throttle lever slightly. See Illust. 8.
2. Disengage the clutch by pressing the clutch pedal all the way down.
3. Hold the clutch pedal in this position and move the gearshift lever to the desired speed.
4. Start the tractor in motion by slowly releasing the clutch pedal and moving the throttle lever to the position where the engine operates best for the load to be handled. **Note:** Do not shift gears while the engine clutch is engaged or while the tractor is in motion.
5. Do not rest your foot on the pedal while driving the tractor, as this will result in excessive wear on the clutch lining.

Always be sure the rear wheels are free to turn. Under any adverse conditions, do not attempt to free the tractor by speeding up the engine and suddenly engaging the clutch. Try backing out instead of going forward.

OPERATION

Driving the Tractor

STOPPING THE TRACTOR

Disengage the clutch by pressing the pedal all the way down. Move the gearshift lever to the neutral position.

LOCKING THE BRAKE

Always lock the brake when the tractor is parked on a grade. To lock the brake, press down on the foot pedal; then place the brake pedal lock in the engaged position. To disengage the lock, press down on the foot pedal and lift the lock out and place it in the disengaged position.

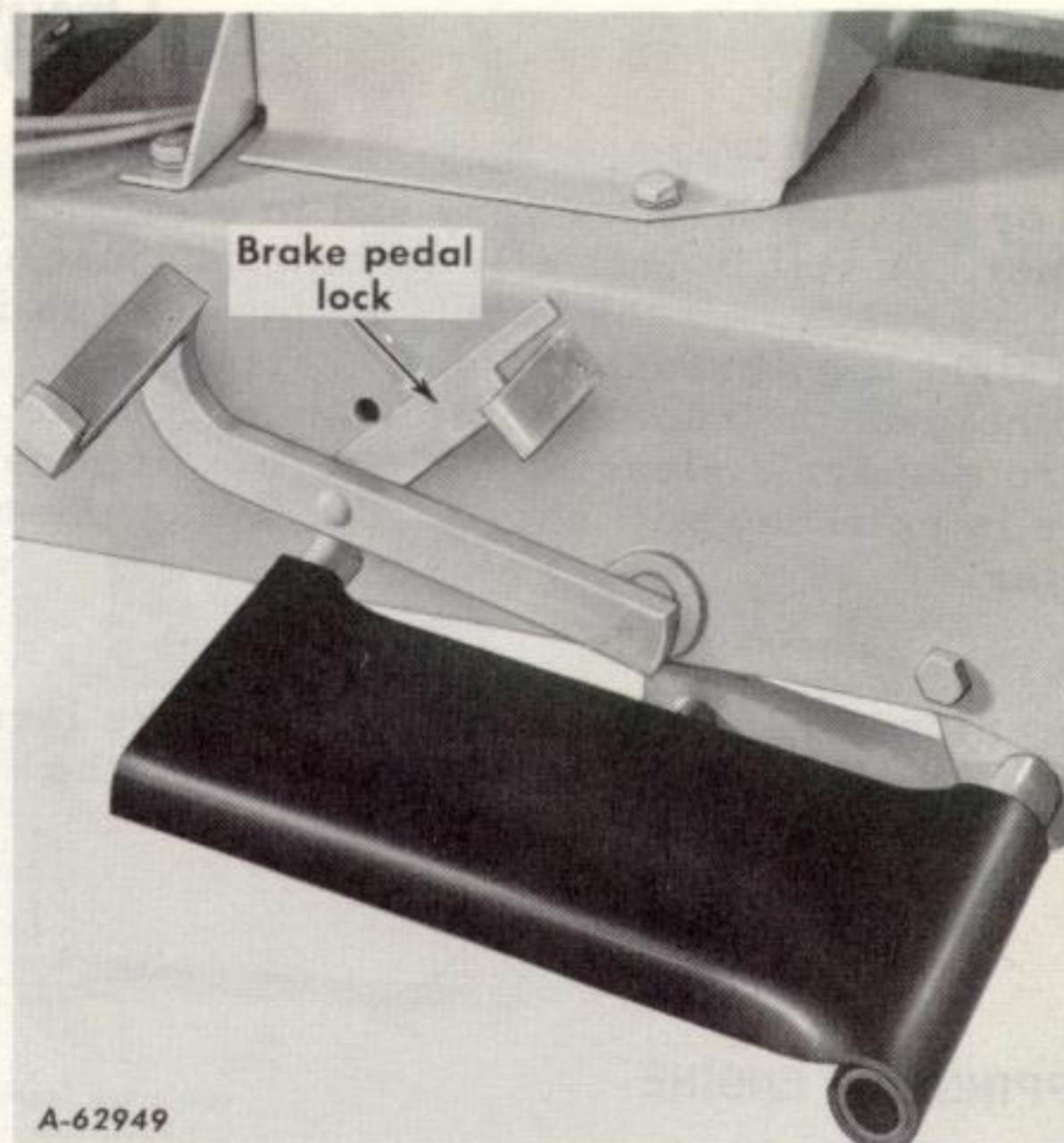

Illust. 10
Brake pedal lock in the engaged position.

Hitching an Implement to the Tractor

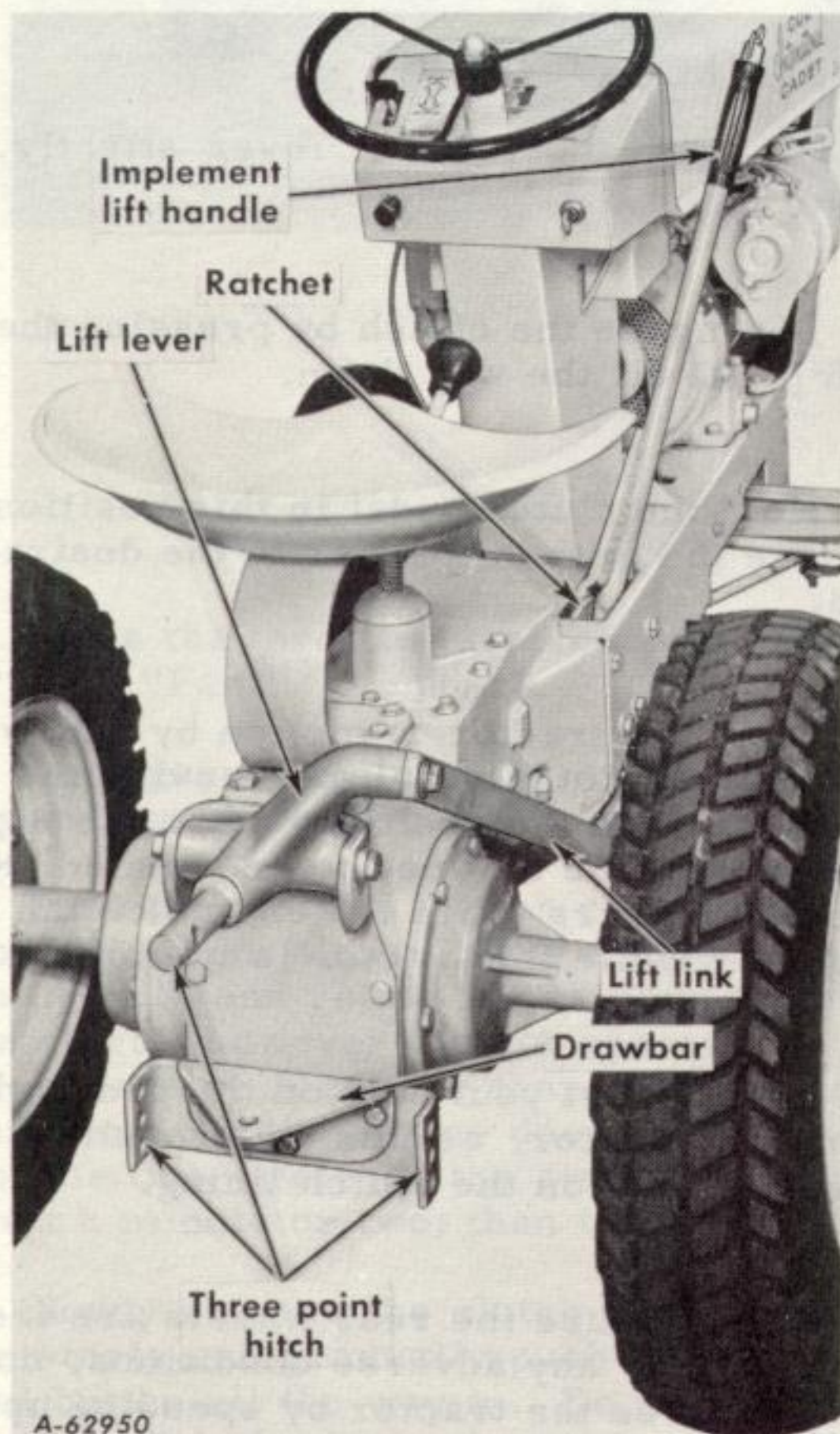

Illust. 10A
Drawbar and three-point hitch.

Trailing-type implements must be hitched to the tractor only at the hitch hole in the drawbar. See Illust. 10A.

When the tractor has a three-point hitch (Illust. 10A), various implements adaptable to the three-point hitch are raised and lowered with the implement lift handle. The lift handle can be set to hold the implement at various heights by use of the six notches in the implement lift ratchet. The lower mounting bracket has three holes which are used for additional adjustment.

When the implement is allowed to float, the position of the lift handle forward travel can be limited by the adjustable stop. Loosen the nut, slide the stop to the required position, and tighten the nut. See Illust. 10B.

Refer to the implement manual for proper hitching instructions.



Illust. 10B
Adjustable stop limiting handle travel.

LUBRICATION

CRANKCASE OIL LEVEL

Never check the oil level while the engine is operating.

The crankcase oil filler plug has a bayonet-type oil level gauge attached to it. Do not run the engine for any length of time with the oil level above the "Full" mark or below the "Low" mark on the gauge. When checking the oil level, the gauge must be withdrawn and wiped clean, then inserted all the way, screwed in finger-tight, and withdrawn, for a true reading.

ENGINE OIL

Oils designated "For Service MS" are recommended for this engine.

TO AID STARTING

To aid starting, the selection of crankcase lubricating oils should be based on the lowest anticipated temperature until the next drain period.

GEAR LUBRICANT

Use only high-quality lubricating oils and greases as specified in the "Lubrication Table". For your own protection, select only oils and greases of recognized manufacture.

Keep your supply of lubricating oil absolutely clean and free from dust. Always use clean containers. Keep the lubricator clean and wipe dirt from the lubrication fittings before applying the lubricator.

Lubrication Table

Point of Lubrication	Fill At Hours	Change At Hours	Capacity	Anticipated Air Temperature	
				Above +32°F	Below +32°F
Engine crankcase	10	30	2-1/2 pts.	SAE-30	SAE-10W
Air cleaner oil cup	10	10	1/3 pt.	SAE-30	SAE-10W
Transmission	100	Yearly	3-1/2 qts.	IH Hy-Tran Fluid or SAE-30 engine oil	
Steering gear housing	Yearly	-	1/4 lb.	Two strokes of the lubricator, using chassis lubricant (pressure-gun grease).	
Motor-generator	100	-	8 or 10 drops of SAE-30 in each oil cup.		
Clutch release collar	10	-	Use chassis lubricant (pressure gun grease) and apply two or three strokes of the lubricator or sufficient grease to flush out old grease and dirt.		
Rear axle carriers	10	-			
Steering knuckles	10	-			
Front wheels	10	-			

LUBRICATION

Lubrication Guide

The symbols around the reference numbers indicate the intervals of lubrication.

▲ -- 10 hours, ■ (with 3 dots) -- 30 hours, ■ (with 1 dot) -- 100 hours, ● -- Periodic

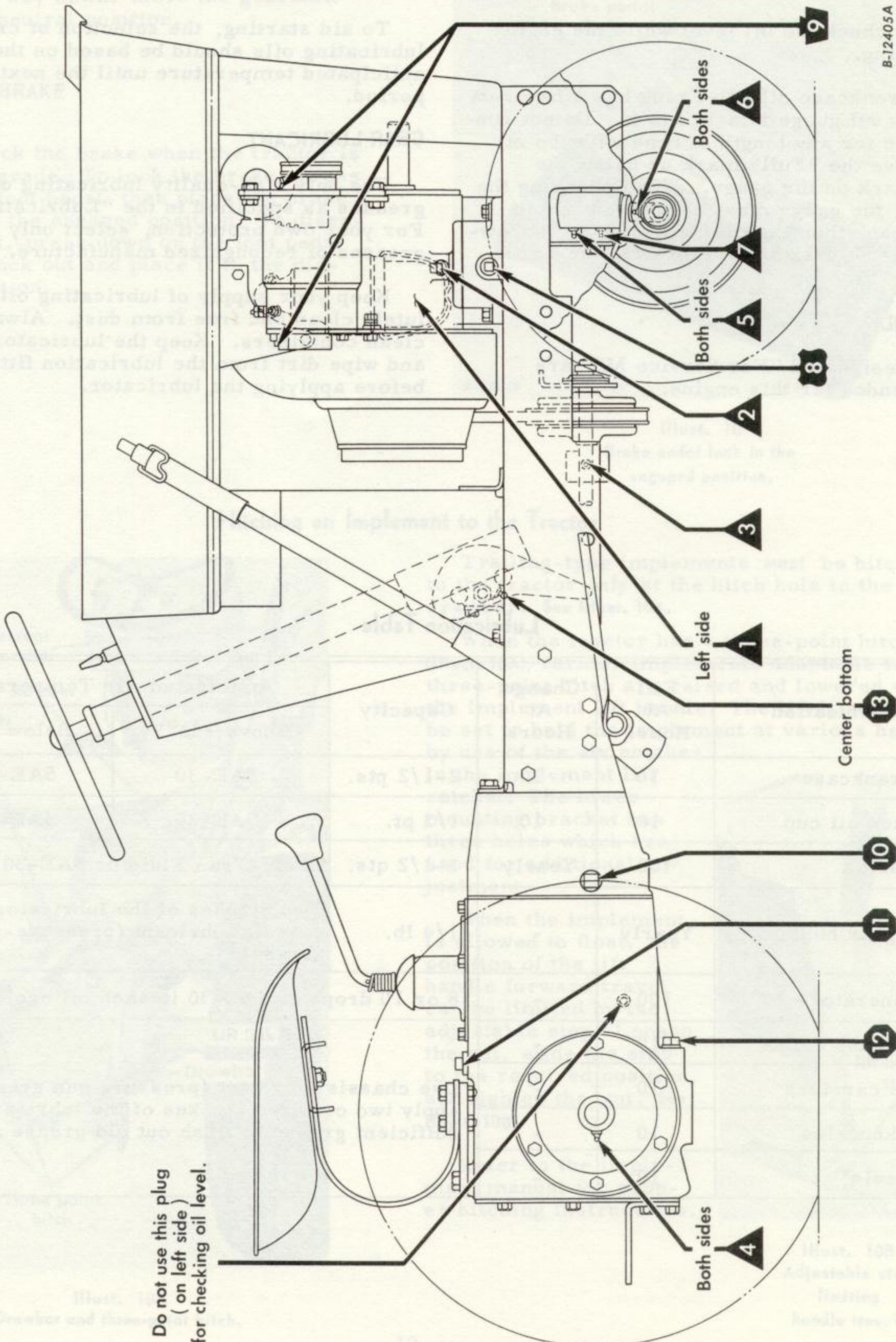

B-12405A

Illust. 12
Lubrication view.

LUBRICATION

Lubrication Guide

--After Every 10 Hours of Operation

1 - Air cleaner.

Clean and refill the oil cup to the oil level bead with new oil. See *Illust. 7*. Refer to the "Lubrication Table".

2 - Oil filler and bayonet-type oil level gauge.

Check the oil (with the engine stopped) and add sufficient new oil to bring it to the "Full" mark on the bayonet gauge. Do not overfill. Do not operate the engine if the oil level is below the "Low" mark on the bayonet gauge.

3 - Clutch release collar.

4 - Rear axle carriers.

5 - Steering knuckles.

6 - Front wheels.

7 - Front axle pivot bolt.

Use chassis lubricant (pressure gun grease) and apply 2 or 3 strokes of the lubricator or sufficient grease to flush out old grease and dirt.

--After Every 30 Hours of Operation

8 - Engine crankcase.

While the oil is warm, remove the drain plug and drain all of the oil from the crankcase. Replace the drain plug. Remove the crankcase filler plug (2). Refill the crankcase with new oil up to the "Full" mark on the oil level gauge. Refer to the "Lubrication Table" for the proper quantity and viscosity to use.

--After Every 100 Hours of Operation

9 - Motor-generator oil cups (2).

Lift the cap on each oil cup and apply eight or ten drops of oil to each cup.

Note: Overlubrication will "gum" the commutator, resulting in reduced output and increased wear. Never oil the commutator and do not lubricate the motor-generator while it is in operation.

--Periodic

Transmission

10 - Oil level and filler plug.

11 - Optional oil filler plug.

12 - Oil drain plug.

Check the oil level periodically. Keep the lubricant up to level plug (10) on the right side of the transmission case. Change the oil in the transmission case at least once a year. Remove the drain plug (12) and remove the oil level and filler plug (10) and allow all of the oil to drain out. Replace the drain plug. Refill with approved lubricant up to the level plug opening and replace the plug.

Optional oil filler plug: The transmission case can also be refilled by removing this filler plug (11) if convenient, and filling up to the level plug opening (10). Replace both plugs. Refer to the "Lubrication Table" for the approved lubricant and capacity.

13 - Steering gear housing.

Once a year apply two strokes of the lubricator, using chassis lubricant (pressure-gun grease).

Miscellaneous

Lubricate the clutch pedal shaft and linkage with eight or ten drops of engine oil.

MAINTENANCE

Periodic Inspections

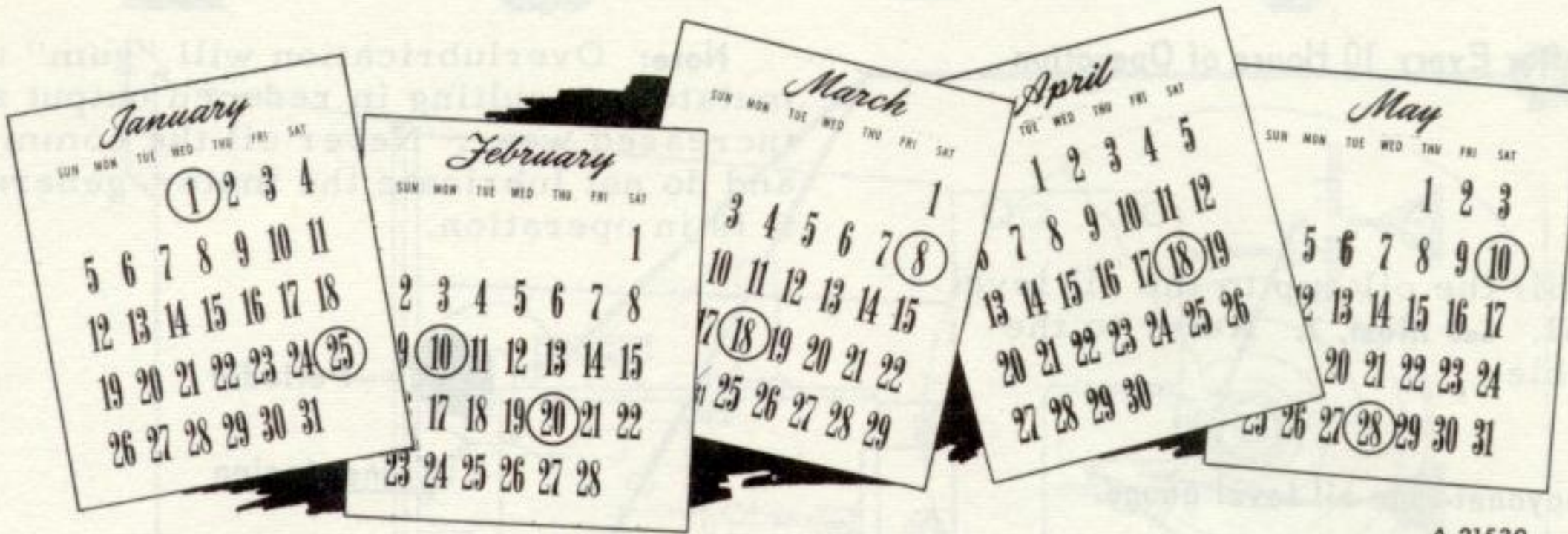

A-21539

AFTER THE FIRST 10 HOURS OF OPERATION

- Drive belt Check the tension. See page 19.
- Motor-generator belt Check the tension. See page 20.

AFTER EVERY 10 HOURS OF OPERATION

- Engine crankcase Check the oil level. See page 11.
- Air cleaner oil cup Remove, clean and refill. See page 13.
- Cooling air screen Check the screen and remove any dirt or chaff.
- Lubrication points See "Lubrication Guide".

AFTER EVERY 30 HOURS OF OPERATION

- Engine crankcase Drain and change oil. See the "Lubrication Guide".
- Gasket joints Check for air leaks.
- Fins, shroud and baffles Wipe off oil and dirt.

AFTER EVERY 50 HOURS OF OPERATION

- Drive belt Check the tension; replace the belt when necessary. See page 19.
- Motor-generator belt Check the tension; replace the belt when necessary. See page 20.
- Air cleaner, complete Remove and clean. See page 16.

AFTER EVERY 100 HOURS OF OPERATION

- Spark plug Remove and clean; check the gap. See page 21.
- Breaker points Check points and reset gap. See page 21.
- Fuel strainer and sediment bowl Take apart and clean. See page 16.
- Air intake and cooling fins Inspect and clean. See page 16.
- Storage battery Check liquid. See page 23.
- Lubrication points See "Lubrication Guide".

AFTER EVERY 150 HOURS OF OPERATION

- Clutch and brake pedal Check for clutch pedal free movement and adjustment. See pages 17 and 18.

MAINTENANCE

Carburetor

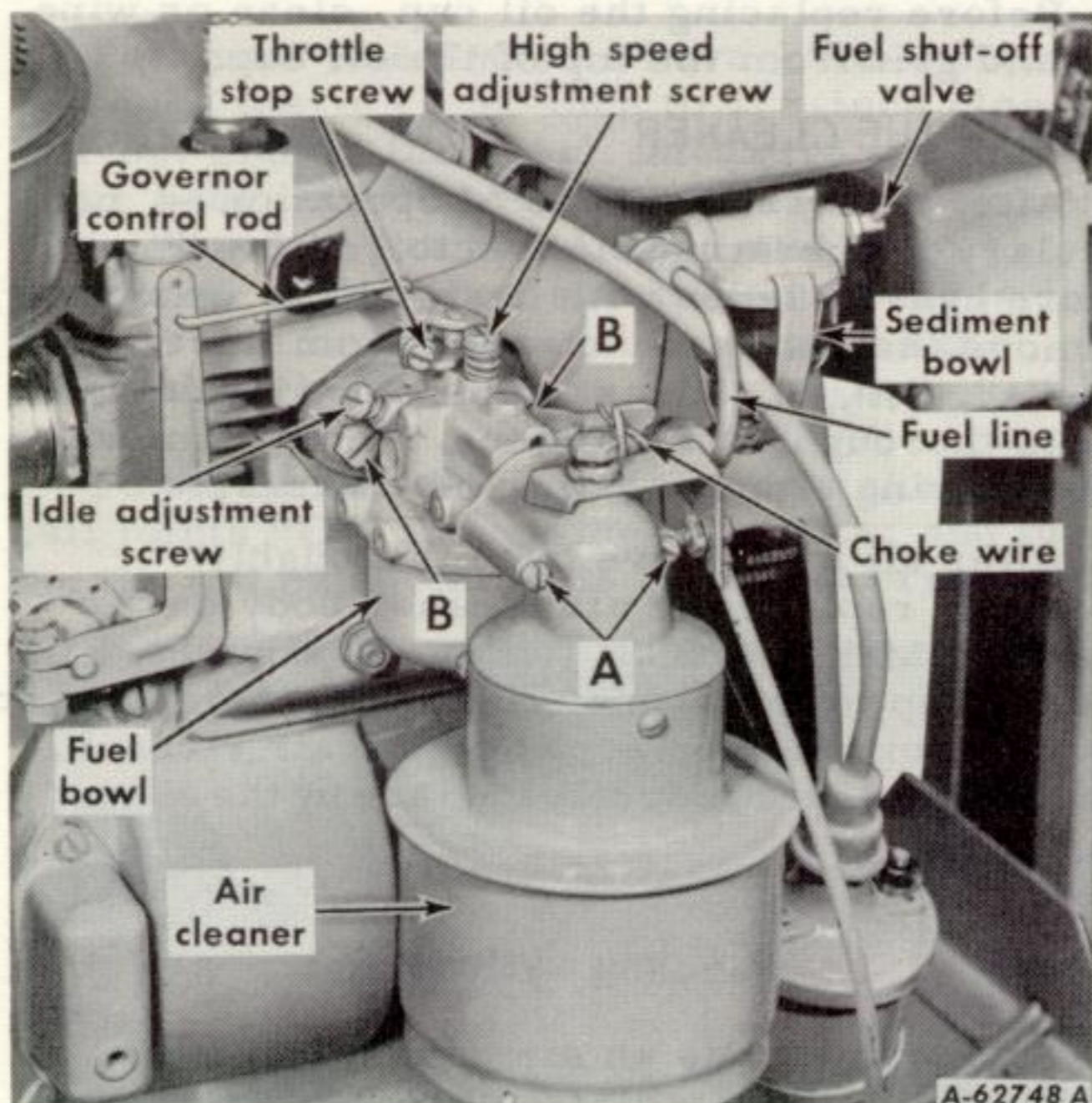

Illust. 15
Carburetor and fuel strainer.

The flange bolts "B" (Illust. 15) which hold the carburetor to the engine should be checked periodically for tightness.

Also the fuel bowl nut under the carburetor should be checked occasionally to see that it is kept tight to avoid any air leakage past the fuel bowl gasket.

CARBURETOR ADJUSTMENTS

The carburetor is adjusted at the factory and under normal operating conditions it will not require readjusting. If this adjustment has been disturbed for any reason, proceed as follows:

ADJUSTING THE HIGH-SPEED ADJUSTMENT SCREW

Turn the high speed adjustment screw (Illust. 15) counter-clockwise two turns from the closed position and start the engine.

After the engine has reached normal operating temperature, accelerate the engine and check its response.

Place the engine under load and adjust the high speed adjustment screw (Illust. 15) to the leanest mixture that will allow satisfactory acceleration and steady governor operation.

If the engine misses and backfires under load, the high speed mixture is too lean. The high speed adjustment screw must be turned counter-clockwise 1/4 turn at a time until the condition is corrected.

If the engine shows a sooty exhaust and is sluggish under load, the high speed mixture is too rich. The high speed adjustment screw must be turned clockwise 1/4 turn at a time until the condition is corrected.

For a final check of the high speed adjustment, operate the engine under load and make any corrections necessary for smooth operation.

ADJUSTING THE IDLE ADJUSTMENT SCREW

The idle adjustment screw (Illust. 15) adjustments should be made at the same time as the high speed adjustment screw adjustments, as each affects the other.

Close the idle adjustment screw to its seat by turning it clockwise; then open it one turn. Start the engine and operate it at fast idling speed (without any load) until thoroughly warm.

While the engine is running at fast idle speed, it is advisable to screw in the throttle stop screw (Illust. 15) a few turns to keep the engine from stopping when the throttle lever is moved to the fully retarded ("Slow") position. The engine will then be idling at a fairly high speed and the throttle stop screw can be backed out a little at a time until the desired idle speed is obtained.

If the engine misses or rolls while backing out the throttle stop screw, the idle adjustment screw may be adjusted in or out until the engine operates smoothly. Speed up the engine for a few seconds; then recheck the idle adjustment. A slight adjustment in or out will give the smoothest idle.

MAINTENANCE

Fuel Strainer

CLEANING THE FUEL STRAINER AND SEDIMENT BOWL

Clean the fuel strainer after every 25 hours of operation. To do this proceed as follows:

1. Close the shut-off valve. See Illust. 15.
2. Loosen the knurled nut under the sediment bowl and remove the bowl and screen.
3. Clean the sediment bowl and screen.
4. When reassembling, be sure the cork gasket between the bowl and the main body is in good condition and does not leak. Use a new gasket if necessary.

Air Cleaner

Incoming air for combustion is filtered by an oil-bath air cleaner. Do not remove the oil cup while the engine is operating.

To remove the oil cup, pull the oil cup bail away from the engine.

Never allow dirt to build up in the oil cup more than 1/2 inch deep. Clean and refill the oil cup every day, or every 10 hours of operation (more frequently when operating under dusty conditions). Refill the oil cup to the oil

level bead with the same grade of oil used in the engine crankcase. For the oil cup capacity, refer to "Lubrication".

Before replacing the oil cup, clean or wipe oil and grit from the top of the oil cup.

WASHING THE CLEANER

After every fifty hours of operation — particularly if operating the tractor in an atmosphere heavily laden with dust, chaff, or lint — remove the entire air cleaner from the tractor (See "A", Illust. 15), disassemble it and wash the parts thoroughly in kerosene. Never remove the filtering element from the cleaner.

After all parts have been thoroughly cleaned, replace the air cleaner body on the tractor. Make sure all joints are airtight. Fill the oil cup to the proper level with the specified grade of oil and replace it on the air cleaner. Be sure it is held securely in place by the oil cup bail.

Cooling System

This tractor has an air cooled engine. Air must be able to circulate freely around the engine, through the screen and shroud, and over the fins of the cylinder head and cylinder block. Keep these areas free of accumulated dirt and trash. Failure to do this will cause the engine to overheat and result in damaged moving parts.

Pneumatic Tires

Follow the instructions and recommendations shown below in order to secure maximum life and efficient service from the pneumatic tires.

INFLATION

Keep the pneumatic tires properly inflated. Underinflation will damage the tire cord body and may also cause the tire to slip on the rim, thus tearing out the tube valve stem. Overinflation results in excessive slippage, which causes rapid tire wear.

Check the air pressure once a week with an accurate low-pressure gauge having one-pound graduations. Do not allow the air pressure to drop below the recommendations.

Always see that tire valve caps are in place and screwed on tightly. The caps prevent the loss of air through the valve core, and also prevent loose soil, mud, gravel, snow, and ice from entering and damaging the valve core and air chamber in the tires.

OPERATING PRESSURE FOR TIRES

Inflate the front and rear tires to six pounds for normal operating conditions, or eight pounds for heavy load operations.

MOUNTING TIRES ON THE RIM

After mounting a new or old tire on the rim, inflate it to 20 pounds pressure to seat the tire bead on the rim flange and to prevent the tire from creeping and shearing off the valve. Then deflate the tire to the correct operating pressure.

CARE OF TIRES

Avoid stumps, stone, deep ruts and other hazards. Cuts in tires should be repaired immediately as neglect decreases the tire life.

Keep tires free from oil and grease as both destroy rubber.

After using the tractor for spraying — insect control work — use water to remove any chemicals that may be on the tires.

TIRE CHAINS

Tire chains will provide increased traction for wet ground conditions, when plowing snow, or pulling heavy loads. Rear wheel weights are recommended for use with chains.

MAINTENANCE

Wheels

FRONT WHEEL TOE-IN

The front wheel should have 1/32-inch to 1/8-inch toe-in (1/32-inch to 1/8-inch closer in front than in the rear). Measure the distance between two points "A" and two points "B", *Illust. 17*. Points "A" and "B" must be on the inside of the wheels at the outer edges and at the same height from the ground as the front wheel hubs.

To adjust the toe-in, disconnect the tie rod ball joints "C", loosen the lock nuts, and turn the tie rod ball joint ends in or out as required.

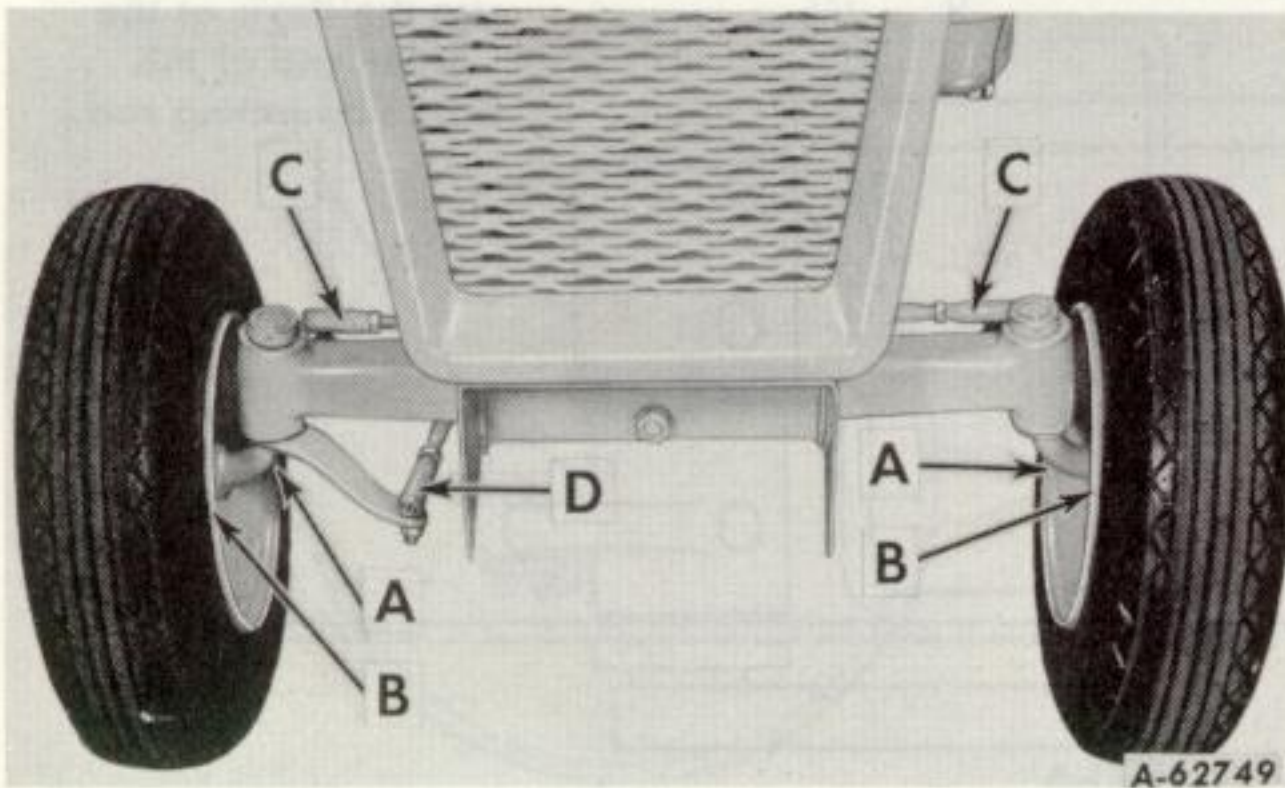

Illust. 17
Front wheel adjustments.

TURNING RADIUS

The front wheels should have an equal angle for left and right turns. If adjustment is necessary, disconnect the drag link ball joint "D", loosen the lock nut and turn the drag link ball joint in or out as required.

REAR WHEEL WEIGHTS

The drawbar pull of a tractor can be increased by the addition of cast-iron weights to the driving wheels.

The rear wheel weights weigh approximately 26 pounds each. Weights can be attached to each rear wheel to reduce slippage and tire wear and increase traction.

The first set of rear wheel weights is attached to each rear wheel with two bolts, lock washers and hex. nuts.

If additional weight is desired, a second set of weights can be attached to each first weight by using two longer bolts, lock washers, and hex. nuts.

Clutch and Brake

As the clutch and brake are both operated by the same pedal, care must be taken to maintain a neutral zone so the clutch is disengaged when the brake is applied.

ADJUSTING THE CLUTCH

It is important that a clearance of from .020 to .030 inch be maintained between the lug on the clutch release collar and the clutch operating yoke. *See Illust. 20*. In order to maintain this clearance, the pedal should have a free movement of not more than 3/16 inch. *See Illust. 18*. This measurement is taken at the point of contact of the pedal arm with the front edge of the pedal return stop.

The clutch pedal adjustments are set at the factory and should not require frequent attention unless the linkage has been disturbed. When it is necessary to adjust the clutch, turn the clevis on the clutch operating rod in or out as required to get the proper measurements.

ADJUSTING THE BRAKE

The brake should engage when the pedal arm is pressed down to within a maximum of 5/8 inch and a minimum of 3/16 inch distance above the top of the left foot support, which serves as the pedal stop. *See Illust. 18*.

It may be possible to push the pedal all the way to the pedal stop, but this is of no concern as long as the brake is engaged when the pedal arm is at least 3/16 inch above the pedal stop.

To adjust the brake, turn the clevis on the brake operating rod (at the brake drum) in or out as required to get this measurement. The brake must not engage before the pedal arm is within the maximum distance of 5/8 inch above the pedal stop.

Continued on next page.

MAINTENANCE

Clutch and Brake

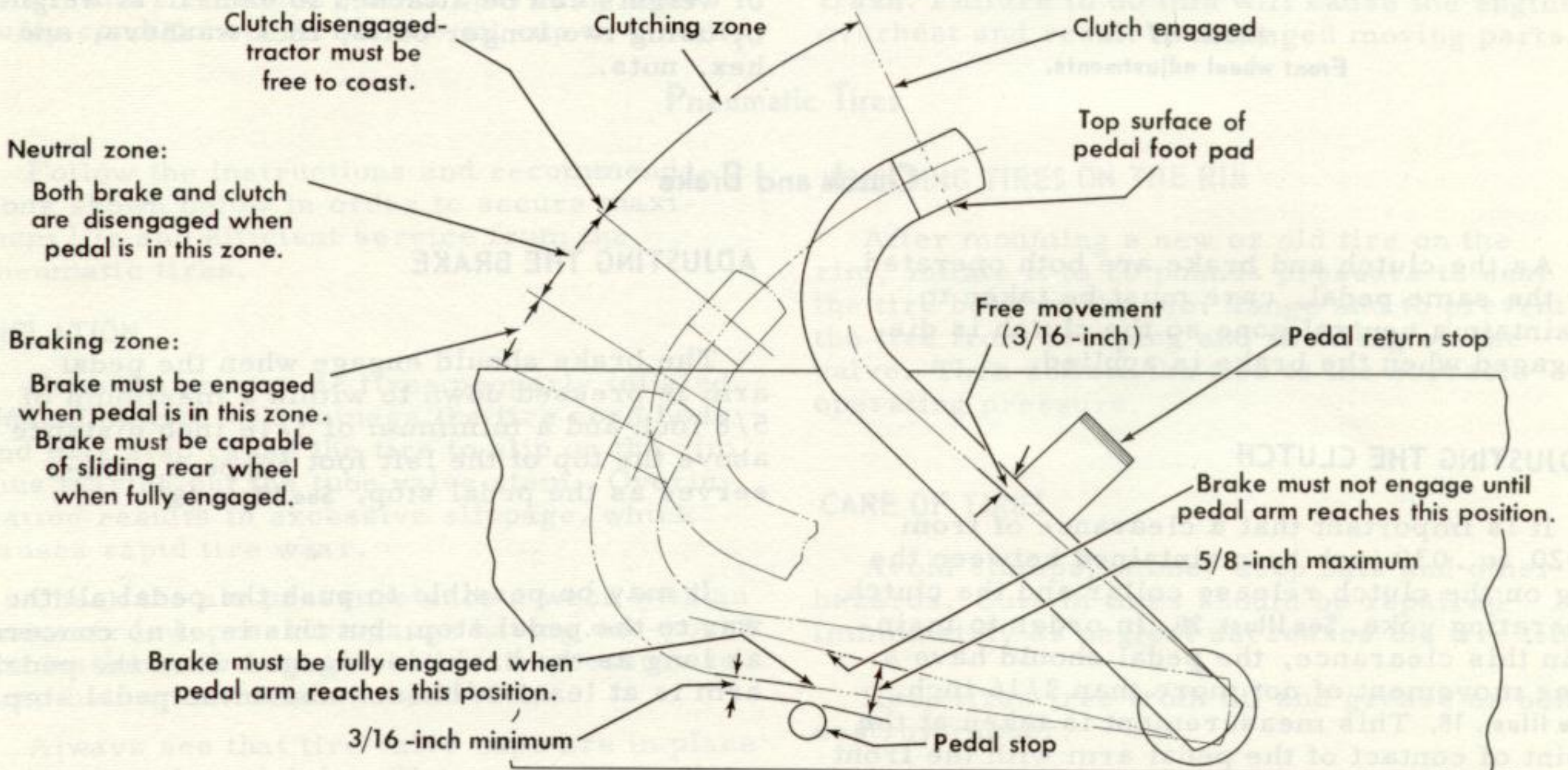
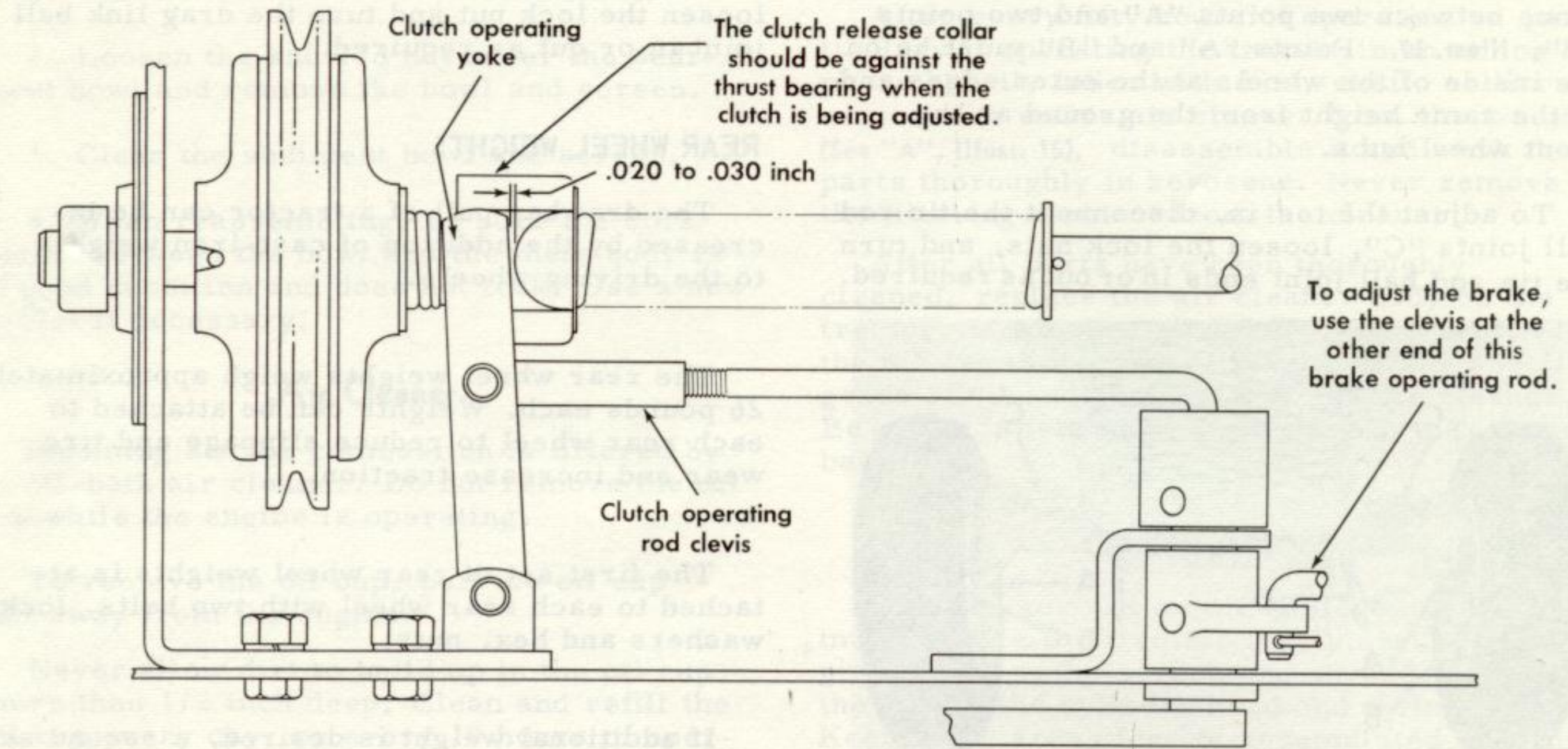

B-12406A

Illust. 18
Brake and clutch adjustment diagram.

MAINTENANCE

Drive Belt

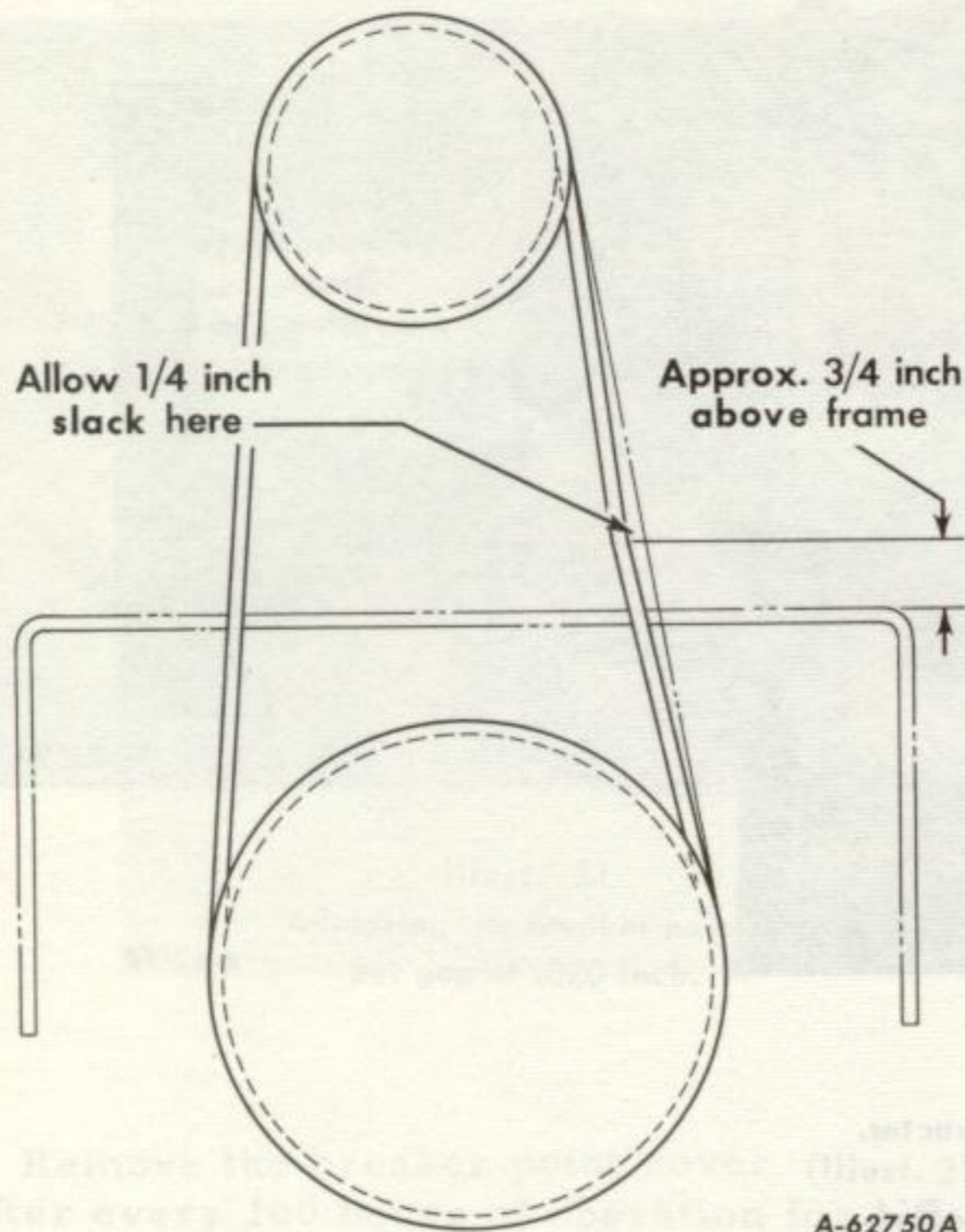

A-62750A

Illust. 19
Correct drive belt tension.

Check the slack of the drive belt after the first 10 hours of operation and every 50 hours of operation thereafter to assure maintenance of the correct tension. The tension is correct when the belt can be depressed a maximum of 1/4 inch by a ten pound force applied midway between the two pulleys.

These instructions also apply when an old belt is replaced with a new one.

ADJUSTING THE DRIVE BELT

Loosen the three cap screws "A" at the left and right sides of the tractor frame. See Illust. 20. Place one end of a small bar or large screwdriver, no longer than 18 inches, on top of the drive shaft and pry down until the correct belt tension is obtained, then tighten the cap screws securely. See Illust. 19A.

If the belt is adjusted too tightly, the clutch may not operate properly.

REMOVING AND REPLACING THE DRIVE BELT

Replace the drive belt when it becomes badly worn. To replace the drive belt, remove the three cap screws "A" from the drive shaft bearing support, remove cotter pin and pin "B" and two cap screws "C". See Illust. 20.

Remove the drive belt from the engine pulley, then lower the drive shaft bearing support and slip the belt over the support. Install the new drive belt in the reverse order of removal and adjust the belt to the proper tension as previously instructed.

On tractors with retractable starter, it is necessary to remove the cap screws holding the pedestal assembly to the frame. Swing the pedestal to the rear about 1/2 inch to gain clearance for the removal of the starter mechanism. The starter mechanism can be removed from the engine by removing the five machine screws in the flange of the starter housing. After the starter mechanism is removed, the belt can be removed and replaced on the drive pulley.

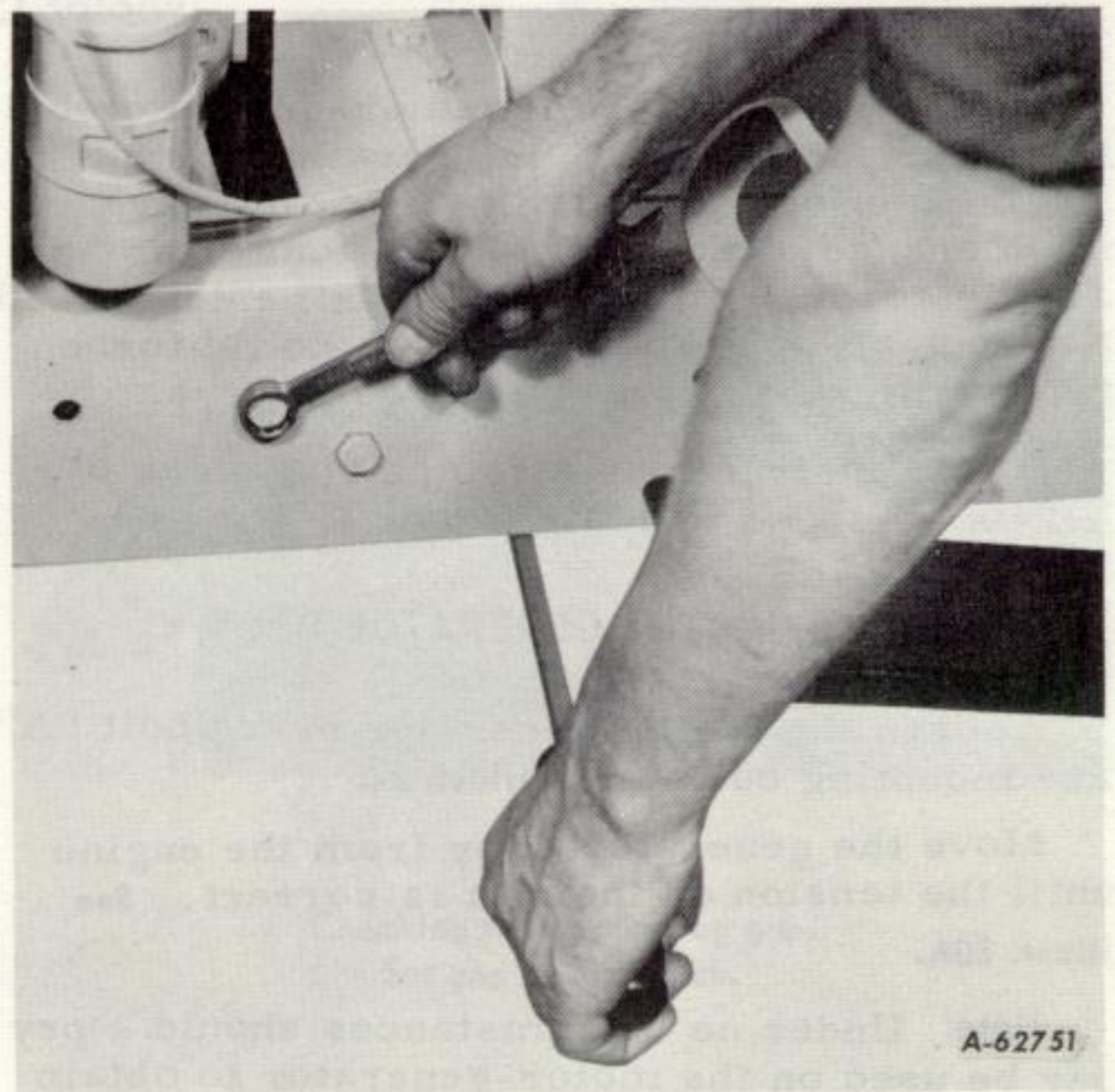

A-62751

Illust. 19A
Adjusting the drive belt tension.

Continued on next page.

MAINTENANCE

Drive Belt

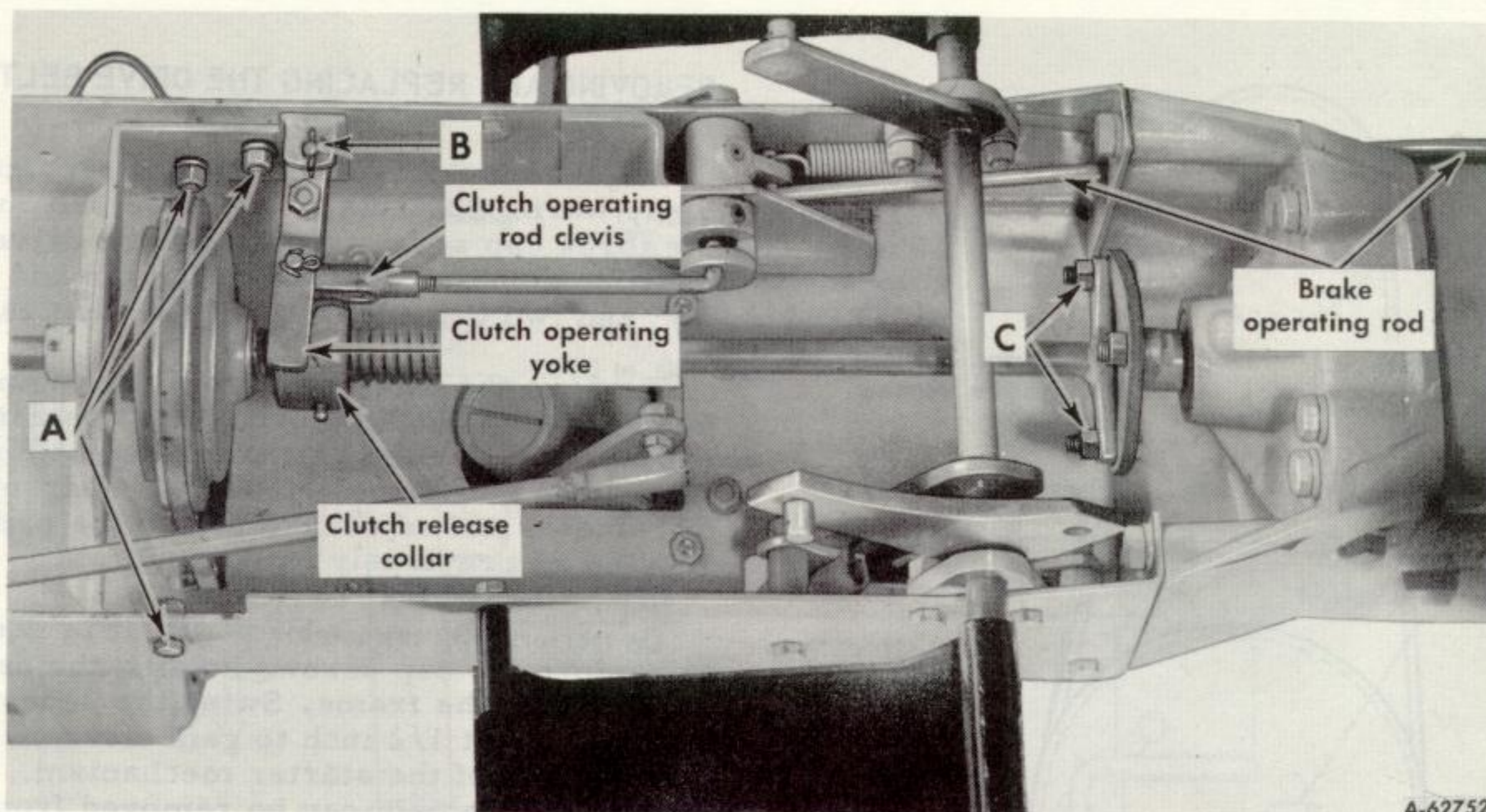

Illust. 20
View of underside of tractor.

Motor-Generator Belt

Check the slack of the motor-generator belt after the first 10 hours of operation and every 50 hours of operation thereafter to assure maintenance of the correct tension. The tension is correct when the belt can be depressed a maximum of 1/4 inch by a ten pound force applied midway between the two pulleys.

These instructions also apply when an old belt is replaced with a new one.

ADJUSTING THE MOTOR-GENERATOR BELT

Loosen the motor-generator brace bolt "A" and mounting bolts "B" Illust. 22.

Move the generator away from the engine until the tension on the belt is correct. See Illust. 20A.

Note: Under no circumstances should a pry bar be used on the motor-generator to obtain belt tension as damage to the bearings will result.

Tighten mounting bolts "B" and brace bolt "A".

REMOVING AND REPLACING THE MOTOR-GENERATOR BELT

Replace the motor-generator belt when it becomes badly worn. To remove the old belt,

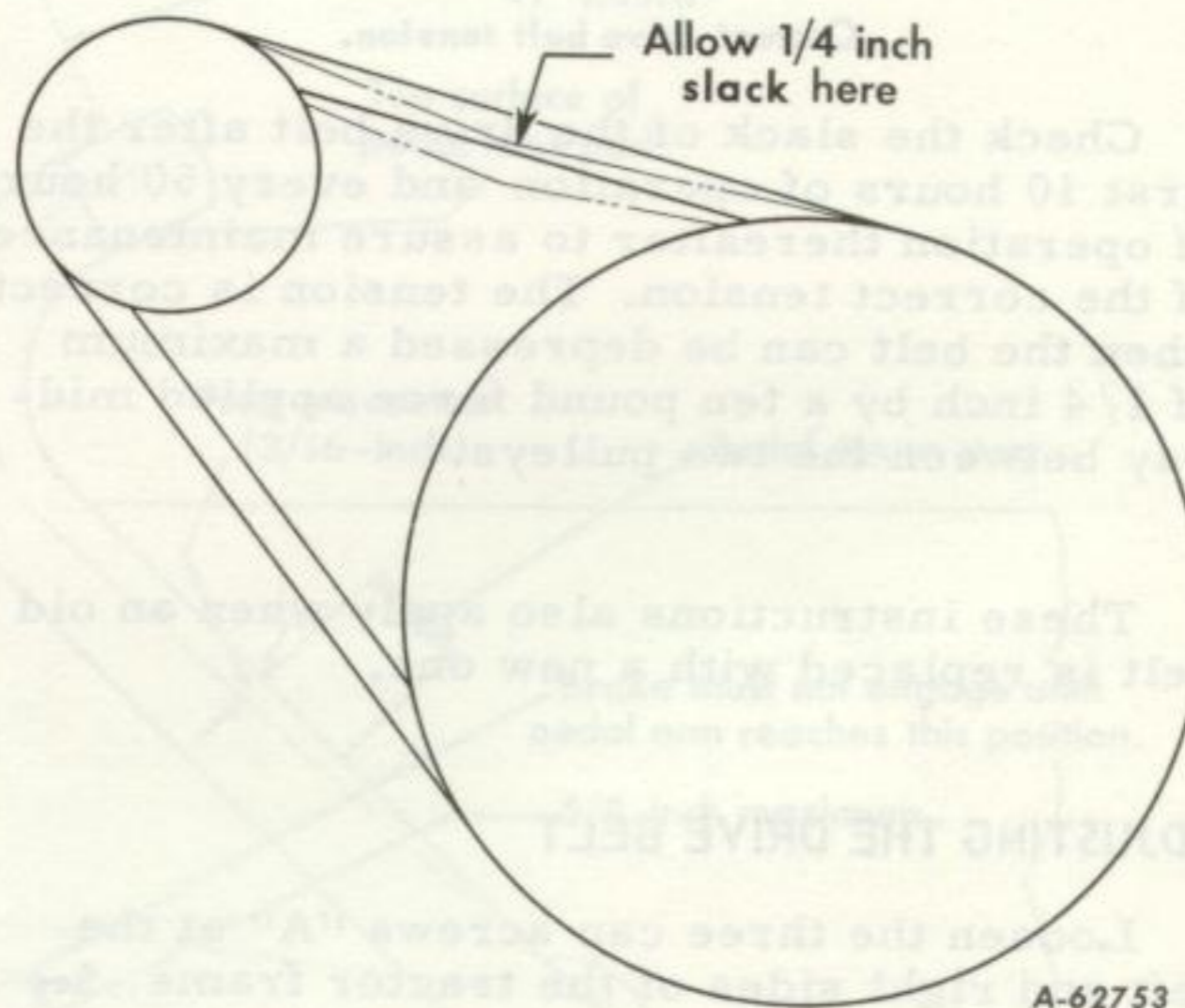

Illust. 20A
Correct motor-generator belt tension.

loosen the motor-generator brace bolt "A" and mounting bolts "B", Illust. 22. Move the generator in toward the engine and slip the old belt off the pulleys and over the crankshaft. Install the new belt in the reverse order of removal and adjust the belt to the proper tension as previously instructed.

MAINTENANCE

Breaker Points and Spark Plug

BREAKER POINTS

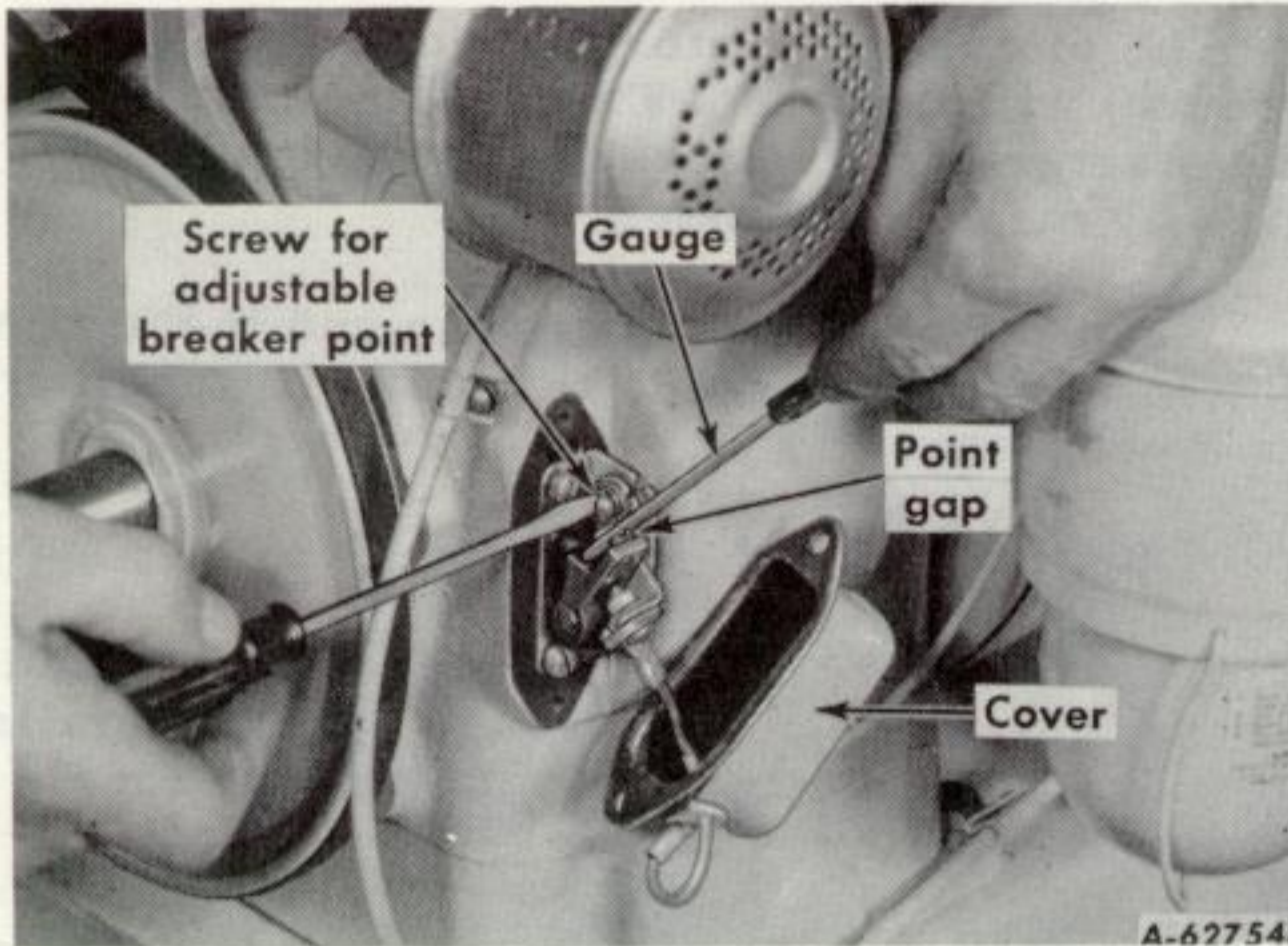

Illust. 21
Adjusting the breaker points
Set gap at .020 inch.

Remove the breaker point cover (Illust. 21) after every 100 hours of operation for cleaning the points and resetting the gap. A gap of .020 inch should be maintained. Replace badly pitted or burned points.

SPARK PLUG

Note: Remove all dirt from the base of the spark plug before removing the spark plug.

Remove the spark plug after every 100 hours of operation for cleaning and checking the gap. A gap of .025 inch should be maintained. When making this adjustment, always bend the outer electrode. Never bend the center electrode, as it may damage the insulator. If the gap between the electrodes is too great, due to improper setting or burning off of the ends, the engine will misfire and be hard to start.

CLEANING THE SPARK PLUG

Sandblasting is the recommended method of cleaning the spark plug. Never scrape or clean the insulator with anything which will scratch the porcelain. Scratched porcelain allows carbon and dirt to accumulate much faster.

Always use a spark plug wrench when removing or reinstalling the plug.

Be sure the gasket is in good condition, and screw the plug in tightly.

Replace a defective plug with a new plug.

See your International Harvester dealer for various makes of replacement plugs.



Illust. 21A
Checking the spark plug gap.
Set gap at .025 inch.

MAINTENANCE

Electric Starting Equipment

The twelve-volt electrical system of the tractor consists principally of a motor-generator, voltage regulator, and a twelve-volt battery.

Use the illustrations on pages 22 and 23, as a guide for identifying the various electrical units and for tracing the electrical cables and connections. Be sure all terminals are clean and securely fastened.

BATTERY AND CABLES

Before working on any part of the tractor, disconnect the battery ground cable. See *Illust. 22*. Do not reconnect this cable until all work has been completed. This will prevent shorting and causing damage to any of the electrical units. Examine the electrical cables occasionally to be sure they are not being chafed by contact with adjacent parts.

MOTOR-GENERATOR

The motor-generator (12-volt, negative ground) will function as a cranking motor when the starter button is pressed, driving the engine by means of a belt.

When the engine is operating and the starter button is not depressed, the unit will function as a generator.

VOLTAGE REGULATOR

A satisfactory charging rate is maintained by the voltage regulator. If the regulator fails to operate correctly, see your International Harvester dealer.

Note: Never place a jumper lead between or accidentally bridge the "BAT" terminal and the "F" terminal on the regulator, as this will damage the regulator.

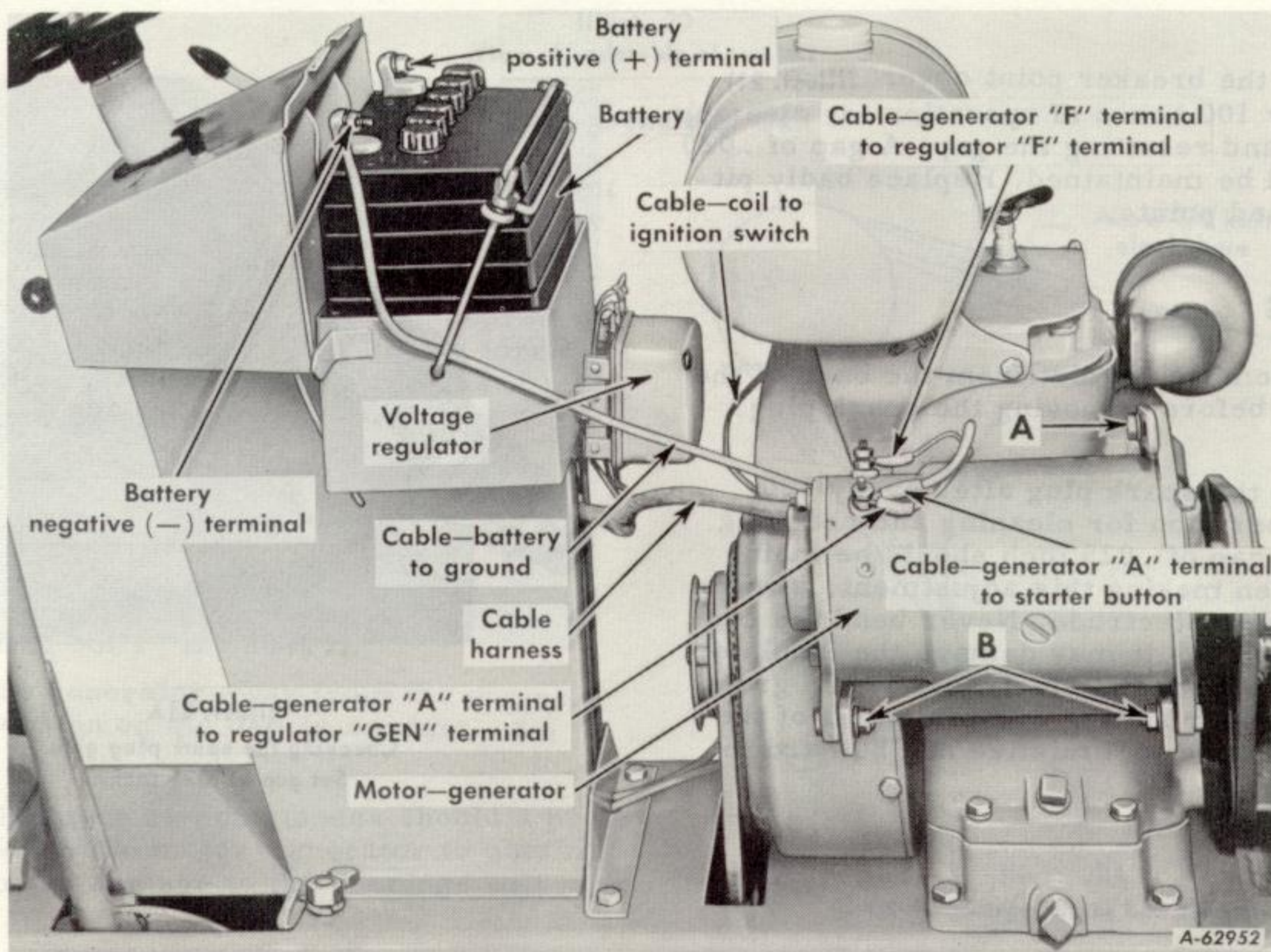

Illust. 22

Electrical units on the right side of the tractor.

MAINTENANCE

Electric Starting Equipment

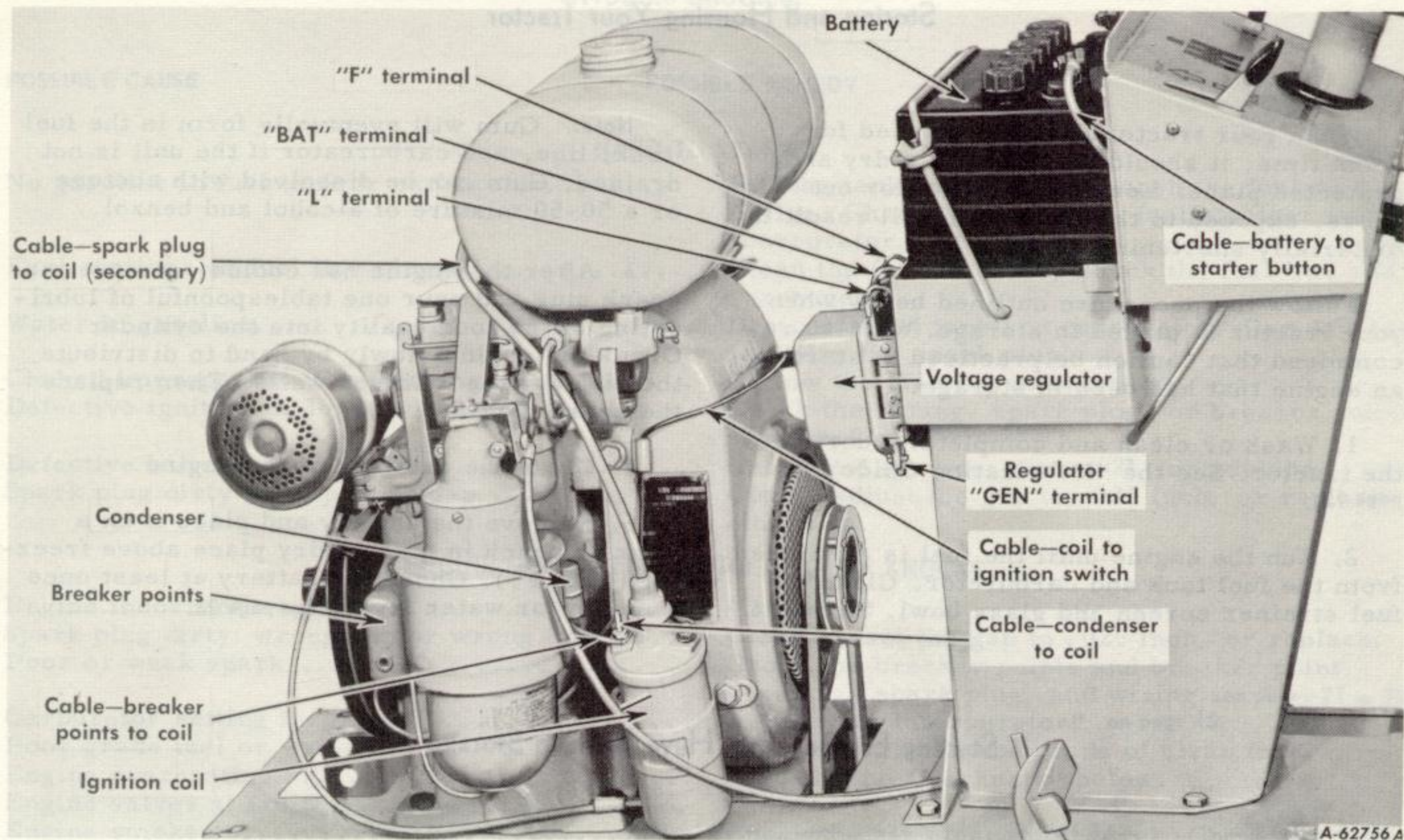

Illust. 23
Electrical units on the left side of the tractor.

Storage Battery

CLEANING AND SERVICING THE BATTERY

Occasionally remove the battery cables and brighten the terminal contact surfaces with wire wool, and reassemble them. Apply a light coat of vaseline or chassis lubricant. Be sure the terminals are clamped tightly and that the battery is fastened securely in the battery box. Replace unserviceable cables. Keep the vent holes in the battery filler caps open.

If the battery shows need of charging, it should be given immediate attention. Keeping the battery, charged not only adds to its life but makes it available for instant use when needed.

LIQUID LEVEL

Check the battery at least once a month for water level.

The electrolyte (acid and water) in each cell should be at ring level at all times to prevent battery failure. When the electrolyte is below this level, pure, distilled water should be added.

Acid or electrolyte should never be added except by a skilled battery man. Under no circumstances add any special battery "dopes," solutions or powders.



Caution! Electric storage batteries give off highly inflammable hydrogen gas when charging and continue to do so for some time after receiving a steady charge.



Do not under any circumstances allow an electric spark or an open flame near the battery. Do not lay tools across battery terminals as this may result in a spark or short circuit which may cause an explosion. Be careful to avoid spilling any electrolyte on hands or clothing.

For dependable battery service, see your International Harvester dealer.

GROUND CABLE

When replacing a battery, make certain the ground cable is connected to the negative (-) terminal on the battery.

MAINTENANCE

Storing and Housing Your Tractor

When your tractor is not to be used for some time, it should be stored in a dry and protected place. Leaving your tractor outdoors, exposed to the elements, will result in materially shortening its life.

Follow the procedure outlined below when your tractor is placed in storage. We also recommend that caution be practiced in starting an engine that has been in storage.

1. Wash or clean and completely lubricate the tractor. See the "Lubrication Guide" on page 12.

2. Run the engine until the fuel is exhausted from the fuel tank and carburetor. Clean the fuel strainer screen and glass bowl. See page 16.

Note: Gum will eventually form in the fuel tank, line, and carburetor if the unit is not drained. Gum can be dissolved with acetone or a 50-50 mixture of alcohol and benzol.

3. After the engine has cooled, remove the spark plug and pour one tablespoonful of lubricating oil of good quality into the cylinder. Crank the engine slowly by hand to distribute the oil over the cylinder walls. Then replace the spark plug.

4. Clean the exterior of the engine.

5. Remove the battery and place it on a rack or bench in a cool, dry place above freezing (+32° F.). Check the battery at least once a month for water level. See page 23.

Starting Engines That Have Been in Storage

1. Remove the spark plug and pour a mixture of one-half gasoline and one-half light lubricating oil into the cylinder; one ounce (two tablespoonfuls) is enough.

2. Crank the engine rapidly until the excess oil has been blown out of the spark plug hole. This operation will loosen any tight piston rings and wash old, gummy oil from valves and piston.

3. Install the spark plug after cleaning and setting the gap.

4. Fill the fuel tank.

5. Install a fully charged battery and be sure the proper connections are made. See Illusts. 22 and 23.

6. Start the engine and let it run slowly.



Caution! Do not accelerate the engine rapidly, or operate it at high speed immediately after starting. Also, keep the doors wide open or move the machine outside the storage room immediately, to avoid danger from exhaust gas.

7. Inflate the tires to the correct operating pressures. See "Pneumatic Tires" on page 16.

MAINTENANCE

Trouble Shooting

POSSIBLE CAUSE

POSSIBLE REMEDY

HARD TO START

No gasoline in fuel tank or carburetor.....	Fill the tank with gasoline; open the fuel shut-valve. Check the fuel line, fuel strainer and carburetor.
Fuel strainer or fuel line clogged.....	Clean the fuel strainer, check the fuel line and carburetor.
Water in gasoline.....	Drain the fuel tank and carburetor. Use new fuel and dry the spark plug.
Choked improperly. Flooded engine	Follow the starting instructions.
Defective ignition or loose wiring	Check the wiring, spark plug, or breaker points. See pages 21 to 23.
Defective battery	Check and service; see page 23, or replace.
Spark plug dirty or improper gap.....	Clean, adjust the gap to .025 inch, or replace the plug.

ENGINE OPERATES IRREGULARLY OR KNOCKS

Engine incorrectly timed	*
Spark plug dirty; wrong gap or wrong type	Clean, reset the gap to .025 inch, or replace.
Poor or weak spark	Check the breaker points and breaker point opening, spark plug, and wiring; see pages 21 to 23.
Carburetor setting incorrect	Adjust; see "Carburetor" on page 15.
Poor grade fuel or water in fuel	Drain and use a good grade of clean fuel.
Engine overheating	See "Engine Overheats" below.
Engine valves at fault.....	*
Engine smokes	Check the air cleaner oil level. Check the fuel delivery at the carburetor. Check for worn piston and rings.*
Excessive carbon in engine	*
Loose piston pin or bearings	*
Broken rings or loose piston	*
Worn connecting rod and main bearings	*
Governor sticking or needs adjustment.	*

LACK OF POWER

Engine cold or overheated	Run the engine until it warms up before putting it under load. See "Engine Overheats" below.*
Engine overloaded	Reduce the load.
Governor not working properly	*
Poor compression	Service the valves and piston rings.*
Poor fuel or too lean a mixture.....	See "Carburetor" on page 15.
Fuel line or strainer obstructed	Clean; see pages 15 and 16.
Fuel tank air vent closed.....	Open the vent in the cap.
Air cleaner clogged or air leakage between carburetor and engine.....	Clean the air cleaner as instructed on page 16. Tighten the carburetor and manifold mounting nuts.
Incorrect timing or faulty ignition	See "Breaker Points and Spark Plug" on page 21.
Clutch slipping	Adjust the free travel of the pedal; see pages 17 and 18.
Brakes drag	Adjust the brake; see pages 17 and 18.

ENGINE OVERHEATS

Insufficient cool air, dirty air intake screen, shroud, or cooling fins.....	Keep the air intake area and cooling fins clean; See "Cooling System" on page 16.
--	---

*See your International Harvester dealer.

SPECIFICATIONS

Capacities (Approximate - U.S. Measure)

Fuel tank	5 qts.
Crankcase	2-1/2 pts.
Transmission case	3-1/2 qts.
Steering gear housing.	1/4 lb.

Transmission (three speeds)

(Speeds based on 6-12 size rear tires)

Speed: 1st	2.3 mph
2nd	3.1 mph
3rd	6.9 mph
Reverse	2.6 mph

Engine

Make and model (with electric starting)	Kohler K 161S
(with retractable starter)	Kohler K 161T
Cylinders	1
Bore	2-7/8 in.
Stroke	2-1/2 in.
Displacement	16-1/4 cu. in.
Rated horsepower (at 60°F and 29.92 in. Hg barometric pressure)	7.0 at 3600 rpm
Engine speed (governed)	
Minimum speed	1000 rpm
Maximum idle speed (no load)	3780 rpm
Maximum (full load)	3600 rpm
Valve clearance (engine cold)006 (intake) .017 (exhaust)
Ignition (with electric starting)	Battery
(with retractable starter)	Magneto
Spark plug gap (14mm plug) (Champion J-8 or equivalent)025 in. gap
Breaker points020 in. gap
Timing (static)	2° after TDC
(running)	20° before TDC
Battery terminal grounded	negative

Foot Brake

External contracting on left rear wheel

Clutch

Double-plate, dry disc, spring loaded.	4-1/2 in.
--	-----------

Wheels and Tread

Front wheels, pneumatic tire size	4.80/4.00-8
Rear wheels, pneumatic tire size	6-12
Wheelbase	42-3/4 in.
Tread	27 in.

General

Length, over-all	62 in.
Width, over-all	33-1/4 in.
Height, over-all (to top of steering wheel)	38 in.
Ground clearance	6 in.
Turning radius	6-3/4 ft.

INDEX

Description	Page No.	Description	Page No.
Air cleaner	16	Ignition and electrical	22, 23
Air cleaner oil cup	7	Ignition switch	6
Adjusting the brake	17, 18	Implement lift handle	6
Adjusting the clutch	17, 18	Inflation	16
Adjusting the drive belt	19, 20	Instruments and controls	5, 6
Adjusting the high-speed adjustment screw	15	Lack of power	25
Adjusting the idle adjustment screw	15	Lifting the hood	5
Adjusting the motor-generator belt	20	Locking the brake	10
Adjusting the seat	9	Lubrication	7, 11
Battery and cables	23	Lubrication guide	12, 13
Battery ground cable	23	Lubrication table	11
Battery liquid level	23	Motor-generator	23
Before starting the tractor	7	Motor-generator belt	20
Brakes	17, 18	Mounting tires on the rim	16
Breaker points and spark plug	21	Operating pressure for tires	16
Capacities	26	Operating the engine	7 to 9
Carburetor	15	Orientation	3
Carburetor adjustments	15	Periodic inspections	14
Carburetor choke lever	6	Pneumatic tires	7, 16, 26
Care of tires	16	Rear wheel weights	17
Choke control button	6	Removing and replacing the drive belt	19
Cleaning and servicing the battery	23	Removing and replacing the motor-generator belt	20
Cleaning the fuel strainer and sediment bowl	16	Retractable starter	6
Cleaning the spark plug	21	Serial numbers	3
Clutch and brake	17, 18	Spark plugs	21
Clutch and brake pedal	5	Specifications	26
Contents, table of	2	Starter button	6
Cooling system	16	Starting engines that have been in storage	24
Crankcase oil level	11	Starting the engine with electric starting	7, 8
Drive belt	19, 20	Starting the engine with manual starting	8, 9
Driving the tractor	9, 10	Starting the tractor	9
Electric starting equipment	22, 23	Stopping the engine	9
Engine	26	Stopping the tractor	10
Engine oil	11	Storage battery	23
Engine operates irregularly or knocks	25	Storing and housing your tractor ...	24
Engine overheats	25	Table of contents	2
Engine serial number	3	Terms of location	3
Filling the fuel tank	7	Throttle lever	6
Foot brake	26	Tire chains	16
Front wheel toe-in	17	To aid starting	11
Fuel strainer	16	Tractor serial number	3
Fuel system	7	Transmission	26
Gear lubricant	11	Trouble shooting	25
Gearshift lever	6	Turning radius	17
General dimension	26	Views of the tractor	4
Governor	6	Voltage regulator	22
Hard to start	25	Washing the air cleaner	16
Hitching the implement to the tractor	10	Wheels	17
		Wheels and tread	26
		Wheel weights	17



The Symbol of Quality Products

Backed By A Dealer Organization
Equipped To Give You—

Service Where You Need It

District Offices in the United States

Aberdeen, S. Dak.
302 First Ave., S.W.
P.O. Box 490
Tel. BAldwin 5-6200

Amarillo, Tex.
714 East 10th St.
P.O. Box 1071
Tel. DRake 3-8373

Atlanta 3, Ga.
580 Whitehall St., S. W.
P.O. Box 4838
Atlanta 2, Ga.
Tel. MUrray 8-4440

Baltimore 5, Md.
6501 Quad Ave.
Tel. EDmondson 6-4700

Billings, Mont.
20 South Broadway
P.O. Box 2515
Tel. 4-4144

Birmingham 4, Ala.
931 North 24th St.
P.O. Box 2573
Birmingham 2, Ala.
Tel. ALpine 1-6274

Broadview, Ill.
1301 West 22nd St.
P.O. Box 126
Tel. FIlmore 3-3800

Camden, N. J.
Suckle Ave. and
National Rd.
Pennsauken 11, N. J.
P.O. Box 1928
Camden 1, N. J.
Tel. NOrmandy 5-3500

Cedar Rapids, Iowa
4401 Sixth St. Road, S.W.
P.O. Box 589
Tel. EMpire 5-6921

Charlotte 6, N. C.
1315 No. Graham St.
P.O. Box 2029
Charlotte 1, N. C.
Tel. EDison 4-2851

Columbus 4, Ohio
3700 Sullivant Ave.
P.O. Box 2797
Tel. BRoadway 9-7392

Dallas 15, Tex.
1809 South Lamar St.
P.O. Box 5145
Dallas 22, Tex.
Tel. RIverside 2-3413

Denver 16, Colo.
4233 East 46th Ave.
P.O. Box 5028
Denver 17, Colo.
Tel. FLorida 5-4481

Des Moines 16, Iowa
1901 East University Ave.
P.O. Box 1437
Des Moines 5, Iowa
Tel. AMherst 6-1191

Fargo, N. Dak.
700 First Ave., North
P.O. Box 591
Tel. ADams 5-6436

Grand Island, Nebr.
2400 West Second St.
Tel. DU Pont 2-1300

Harrisburg, Pa.
1017 Maclay St.
P.O. Box 84
Tel. CEdar 8-5277

Houston 11, Tex.
4619 Navigation Blvd.
P.O. Box 1425
Houston 1, Tex.
Tel. WALnut 3-2841

Indianapolis 7, Ind.
1065 W. Washington St.
Tel. MELrose 9-1491

Jacksonville 1, Fla.
1986 West Beaver St.
P.O. Box 869
Tel. ELgin 6-8451

Kansas City 15, Kans.
3201 McCormick Road
Tel. FINley 2-7200

Lansing 6, Mich.
1800 Grand River Ave.
P.O. Box 1316
Lansing 4, Mich.
Tel. IVanhoe 5-2215

Lexington, Ky.
1105 Eastland Drive
P.O. Box 481
Tel. 2-6008

Little Rock, Ark.
3601 W. 65th St.
P.O. Box 2541
Tel. LOcust 5-5576

Los Angeles, Calif.
530 N. Baldwin Park Blvd.
P.O. Box 2147
City of Industry, Calif.
Tel. YOrktown 2-3271

Madison 4, Wis.
2320 Darwin Road
P.O. Box 1111
Madison 1, Wis.
Tel. CHerry 9-2181

Mason City, Iowa
25 Nineteenth St., S.W.
P.O. Box 201
Tel. GArden 3-6513

Memphis 6, Tenn.
237 West Olive Ave.
P.O. Box 2864
Memphis 2, Tenn.
Tel. WHitehall 2-3261

Minneapolis, Minn.
2572 University Ave.
St. Paul 14, Minn.
Tel. MIDway 6-7301

Minot, N. Dak.
11 Second St., N.E.
Tel. TEMple 2-1151

New Orleans 19, La.
501 North Alexander St.
P.O. Box 19285
Tel. HUnter 2-2181

Oakland 8, Calif.
2855 Cypress St.
P.O. Box 4676
Oakland 23, Calif.
Tel. GLencourt 2-2828

Oklahoma City 8, Okla.
5125 W. Reno Ave.
P.O. Box 1337
Oklahoma City 1, Okla.
Tel. WIndsor 6-2687

Omaha 2, Nebr.
1201 South 16th St.
P.O. Box 1653
Omaha 8, Nebr.
Tel. HARney 8200

Peoria, Ill.
407 Rock Island Ave.
P.O. Box 1019
Tel. 685-7687

Pittsburgh, Pa.
1000 Ferry St.
Leetsdale, Pa.
Tel. POplar 6-7600

Portland 22, Oreg.
2001 S.E. Harvester Drive
P.O. Box 5967
Tel. OLive 4-5481

Richmond 30, Va.
1905 Westmoreland St.
P.O. Box 6857
Tel. ELgin 5-7907

St. Louis, Mo.
5902 No. Lindbergh Blvd.
Hazelwood, Mo.
Tel. PERshing 1-0430

St. Paul 14, Minn.
2572 University Ave.
Tel. MIDway 6-7301

Salt Lake City 1, Utah
435 W. Fourth South St.
P.O. Box 660
Salt Lake City 10, Utah
Tel. EMpire 4-7861

Sioux Falls, S. Dak.
196 East Sixth St.
Tel. EDison 4-9921

Spokane 3, Wash.
715 East Sprague Ave.
P.O. Box 223
Spokane 10, Wash.
Tel. MADison 4-9271

Springfield, Ill.
217 North Ninth Street
P.O. Box 99
Tel. LAKeside 2-4481

Springfield, Mass.
P.O. Box 514
Westfield, Mass.
Tel. LOgan 8-8651

Syracuse 1, N. Y.
210 Teall Avenue
P.O. Box 979
Tel. GRANite 4-2923

Wichita 19, Kans.
410 E. 37th St. North
P.O. Box 1720
Wichita 1, Kans.
Tel. TEMple 8-1495

INTERNATIONAL HARVESTER COMPANY • 180 NORTH MICHIGAN AVENUE • CHICAGO 1, ILLINOIS, U.S.A.

1-14-61.